



# UNIT 4004 - 'THE DALERIDGE' - LOT 94

## SB-12 ENERGY EFFICIENCY DESIGN MATRIX

PRESCRIPTIVE COMPLIANCE SB-12 (SECTION 3.1.1) TABLE 3.1.1.3.A

### PACKAGE A1

SPACE HEATING FUEL	
<input checked="" type="checkbox"/> GAS	<input type="checkbox"/> OIL
<input type="checkbox"/> ELECTRIC	<input type="checkbox"/> PROPANE
<input type="checkbox"/> EARTH	<input type="checkbox"/> SOLID FUEL

BUILDING COMPONENT	REQUIRED	PROPOSED
<b>INSULATION RSI (R) VALUE</b>		
CEILING W/ ATTIC SPACE	10.56 (R60)	10.56 (R60)
CEILING W/O ATTIC SPACE	5.46 (R31)	5.46 (R31)
EXPOSED FLOOR	5.46 (R31)	5.46 (R31)
WALLS ABOVE GRADE	3.87 (R22)	3.87 (R22)
BASEMENT WALLS	3.52 ci (R20 ci) *	3.52 ci (R20 ci) *
* PROPOSED VALUES MAY BE SUBSTITUTED W/ 2.11+1.76ci (R12+R10ci)		
BELOW GRADE SLAB ENTIRE SURFACE > 600mm BELOW GRADE	-	-
EDGE OF BELOW GRADE SLAB ≤ 600mm BELOW GRADE	1.76 (R10)	1.76 (R10)
HEATED SLAB OR SLAB ≤ 600mm BELOW GRADE	1.76 (R10)	1.76 (R10)
<b>WINDOWS &amp; DOORS</b>		
WINDOWS/SLIDING GLASS DOORS (MAX U-VALUE)	1.6	1.6
SKYLIGHTS (MAX. U-VALUE)	2.8	2.8
<b>APPLIANCE EFFICIENCY</b>		
SPACE HEATING EQUIP. (AFUE%)	96%	96%
HRV EFFICIENCY (%)	75%	75%
DHW HEATER (EF)	0.8	0.8

- 1 - TITLE PAGE
- 2 - BASEMENT PLAN ELEV. 'A' - LOT 94
- 3 - GROUND FLOOR PLAN ELEV. 'A' - LOT 94
- 4 - SECOND FLOOR PLAN ELEV. 'A' - LOT 94
- 5 - OPT. SECOND FLOOR PLAN ELEV. 'A' W/ 5 BEDROOM - LOT 94
- 6 - FRONT ELEVATION 'A' - LOT 94
- 7 - LEFT SIDE ELEVATION 'A' - LOT 94
- 8 - RIGHT SIDE ELEVATION 'A' - LOT 94
- 9 - REAR ELEVATION 'A' - LOT 94
- 10 - PARTIAL REAR ELEVATION 'A' FOR OPT. LOGGIA
- 11 - CROSS SECTION 'A-A'
- 12 - CONSTRUCTION NOTES
- 13 - CONSTRUCTION NOTES
- W1 - WALK OUT DECK CONDITION
- W2 - LOOK OUT DECK CONDITION
- W3 - WALK OUT BASEMENT CONDITION
- W4 - DECK DETAILS 1
- W5 - DECK DETAILS 2
- W6 - DECK DETAILS 3
- W7 - DECK DETAILS 4

### AREA CALCULATIONS

#### EL. 'A'

GROUND FLOOR AREA	1493 sq. ft. (138.70 sq. m.)
SECOND FLOOR AREA	1817 sq. ft. (168.80 sq. m.)
SUBTOTAL	3310 sq. ft. (307.51 sq. m.)
DEDUCT ALL OPEN AREAS	29 sq. ft. (2.69 sq. m.)
TOTAL NET AREA	3281 sq. ft. (304.81 sq. m.)
FINISHED BASEMENT AREA	168 sq. ft. (15.61 sq. m.)
COVERAGE W/OUT PORCH	1904 sq. ft. (176.89 sq. m.)
COVERAGE W/ PORCH	2061 sq. ft. (191.47 sq. m.)
COVERAGE W/OPT. LOGGIA	2207 sq. ft. (205.04 sq. m.)

#### WINDOW / WALL AREA CALCULATIONS

	EL. 'A'	EL. 'A'	EL. 'A' - WOD
STD. PLAN	4056.25 sq. ft.	4056.25 sq. ft.	4079.58 sq. ft.
OPT. 5 BEDR PLAN	(376.84 sq. m.)	(376.84 sq. m.)	(379.01 sq. m.)
GROSS WALL AREA	432.93 sq. ft.	455.60 sq. ft.	458.93 sq. ft.
GROSS WINDOW AREA (INCL. GLASS DOORS & SKYLIGHTS)	(40.22 sq. m.)	(42.33 sq. m.)	(42.64 sq. m.)
TOTAL WINDOW %	10.67 %	11.23 %	10.69 %

EL. 'A' - WOD	EL. 'A' - LOD	EL. 'A' - LOD	EL. 'A' - WOB	EL. 'A' - WOB
OPT. 5 BEDR PLAN	4145.21 sq. ft.	4145.21 sq. ft.	4362.50 sq. ft.	4362.50 sq. ft.
STD. PLAN	(385.10 sq. m.)	(385.10 sq. m.)	(405.29 sq. m.)	(405.29 sq. m.)
OPT. 5 BEDR PLAN	458.93 sq. ft.	478.93 sq. ft.	526.65 sq. ft.	549.32 sq. ft.
STD. PLAN	(42.64 sq. m.)	(44.49 sq. m.)	(48.93 sq. m.)	(51.03 sq. m.)
TOTAL WINDOW %	11.25 %	11.55 %	12.07 %	12.59 %

10. REVISED AS PER ENG. COMMENTS	2018/11/30	OF
9. REVISED FOR LOT 94	2018/10/17	OF
8. REVISED AS PER CITY COMMENTS	2018/09/04	OF
7. REVISED AS PER ENG. COMMENTS	2018/05/31	MC
6. REVISED AS PER CLIENT COMMENTS	2018/05/14	OF
5. REVISED AS PER ENG. COMMENTS	2018/04/17	MC
4. REVISED AS PER FLOOR MANUF. LAYOUTS	2017/11/27	OF
3. REVISED AS PER ROOF MANUF. LAYOUTS	2017/11/16	MC
2. REVISED AS PER CLIENT COMMENTS	2017/11/03	OF
1. ISSUED FOR CLIENT REVIEW	2017/09/18	OF
REVISIONS	DATE (YYYY/MM/DD)	BY

### TITLE PAGE

**GOLDPARK**  
WORTH MORE™

**PINE VALLEY**  
FOREVERGREEN

THE UNDERSIGNED HAS REVIEWED AND TAKES RESPONSIBILITY FOR THIS DESIGN AND HAS THE QUALIFICATIONS AND MEETS THE REQUIREMENTS SET OUT IN THE ONTARIO BUILDING CODE TO BE A DESIGNER.

QUALIFICATION INFORMATION  
Orin Fairbairn 20201

REGISTRATION INFORMATION  
HUNT DESIGN ASSOCIATES INC. 19695

**HUNT**  
DESIGN ASSOCIATES INC.  
www.huntdesign.ca

**GOLDPARK HOMES - 217020**  
PINE VALLEY, VAUGHAN ONT.

Drawn By HDAL/OF Checked By OF Scale 3/16"=1'-0"

8966 Woodbine Ave, Markham, ON L3R 0J7 T 905.737.5133 F 905.737.7326

**UNIT 4004 - THE DALERIDGE**  
REV. 2018/11/30

File Number 217020WS4004-LOT 94

Page Number 1 of 13

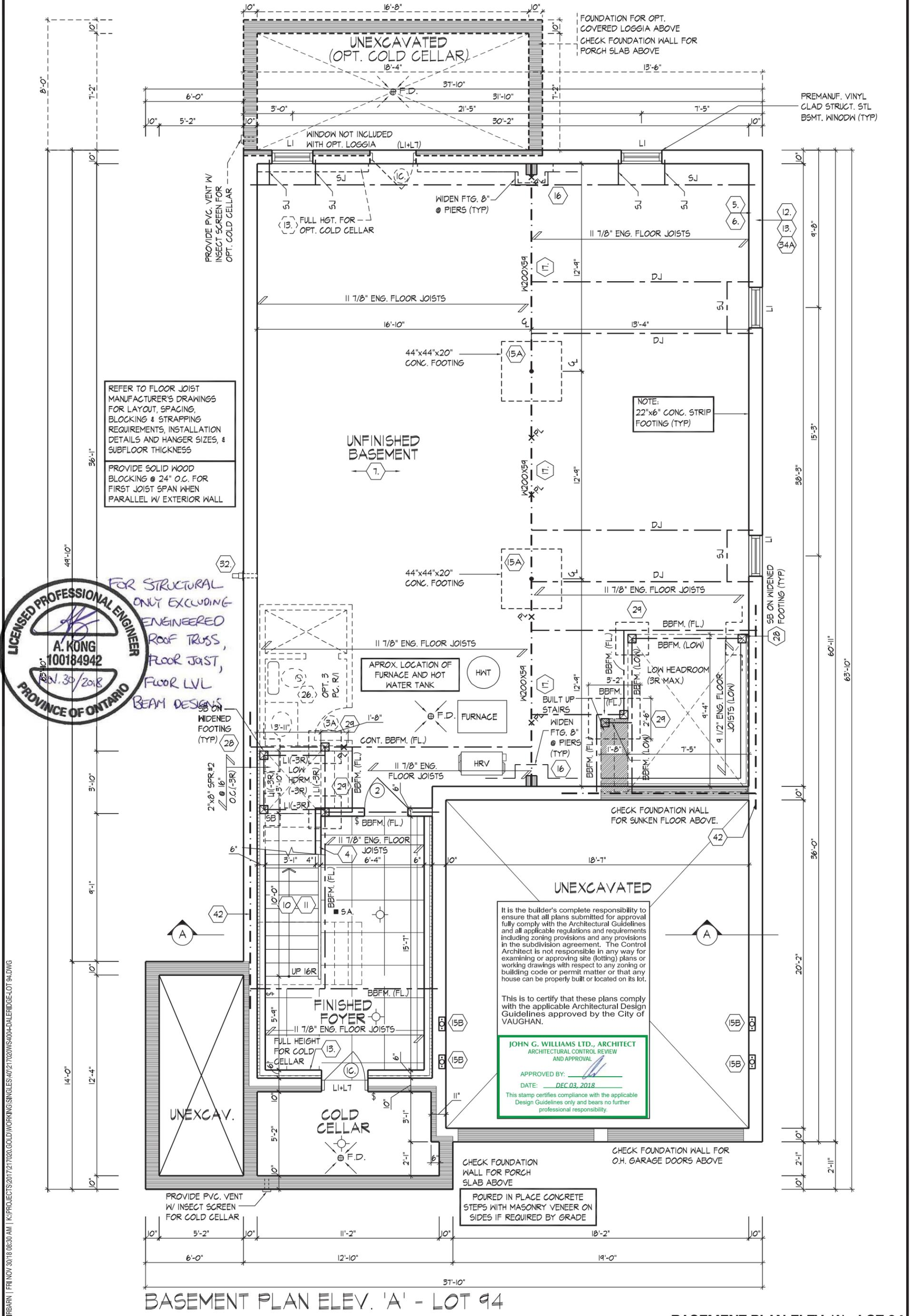

REFER TO FLOOR JOIST MANUFACTURER'S DRAWINGS FOR LAYOUT, SPACING, BLOCKING & STRAPPING REQUIREMENTS, INSTALLATION DETAILS AND HANGER SIZES, & SUBFLOOR THICKNESS

PROVIDE SOLID WOOD BLOCKING @ 24" O.C. FOR FIRST JOIST SPAN WHEN PARALLEL W/ EXTERIOR WALL

NOTE: 22"x6" CONC. STRIP FOOTING (TYP)

It is the builder's complete responsibility to ensure that all plans submitted for approval fully comply with the Architectural Guidelines and all applicable regulations and requirements including zoning provisions and any provisions in the subdivision agreement. The Control Architect is not responsible in any way for examining or approving site (lotting) plans or working drawings with respect to any zoning or building code or permit matter or that any house can be properly built or located on its lot.

This is to certify that these plans comply with the applicable Architectural Design Guidelines approved by the City of VAUGHAN.

**JOHN G. WILLIAMS LTD., ARCHITECT**  
ARCHITECTURAL CONTROL REVIEW AND APPROVAL

APPROVED BY: \_\_\_\_\_  
DATE: DEC 03, 2018

This stamp certifies compliance with the applicable Design Guidelines only and bears no further professional responsibility.



FOR STRUCTURAL ONLY EXCLUDING ENGINEERED ROOF TRUSS, FLOOR JOIST, FLOOR LVL BEAM DESIGNS

BASEMENT PLAN ELEV. 'A' - LOT 94

BASEMENT PLAN ELEV. 'A' - LOT 94

THE UNDERSIGNED HAS REVIEWED AND TAKES RESPONSIBILITY FOR THIS DESIGN AND HAS THE QUALIFICATIONS AND MEETS THE REQUIREMENTS SET OUT IN THE ONTARIO BUILDING CODE TO BE A DESIGNER.

QUALIFICATION INFORMATION  
Orin Fairbairn  
NAME  
REGISTRATION INFORMATION  
HUNT DESIGN ASSOCIATES INC.

**HUNT**  
DESIGN ASSOCIATES INC.  
www.huntdesign.ca

**GOLDPARK HOMES - 217020**  
PINE VALLEY, VAUGHAN ONT.UNIT 4004 - THE DALERIDGE  
REV. 2018/11/30

Drawn By: HDAL/OF  
Checked By: OF  
Scale: 3/16"=1'-0"  
File Number: 217020WS4004-LOT 94  
Page Number: 2 of 13

8966 Woodbine Ave, Markham, ON L3R 0J7 T 905.737.5133 F 905.737.7326

All drawings specifications related documents and design are the copyright property of Hunt Design Associates (H.D.A). Reproduction of this property in whole or in part is strictly prohibited without H.D.A.'s written permission (H.D.A. assumes no responsibility or liability for this property unless it bears the appropriate BCIN number and original signature).

10"x10" PREF. HOLLOW COL. W/ CAP & BASE W/ INT. 6"x6" BUILT-UP POST TIED TOP & BOTTOM (TYP.) FOR OPT. BALCONY



FOR STRUCTURAL ONLY EXCLUDING ENGINEERED ROOF TRUSS, FLOOR JOIST, FLOOR LVL BEAM DESIGNS.

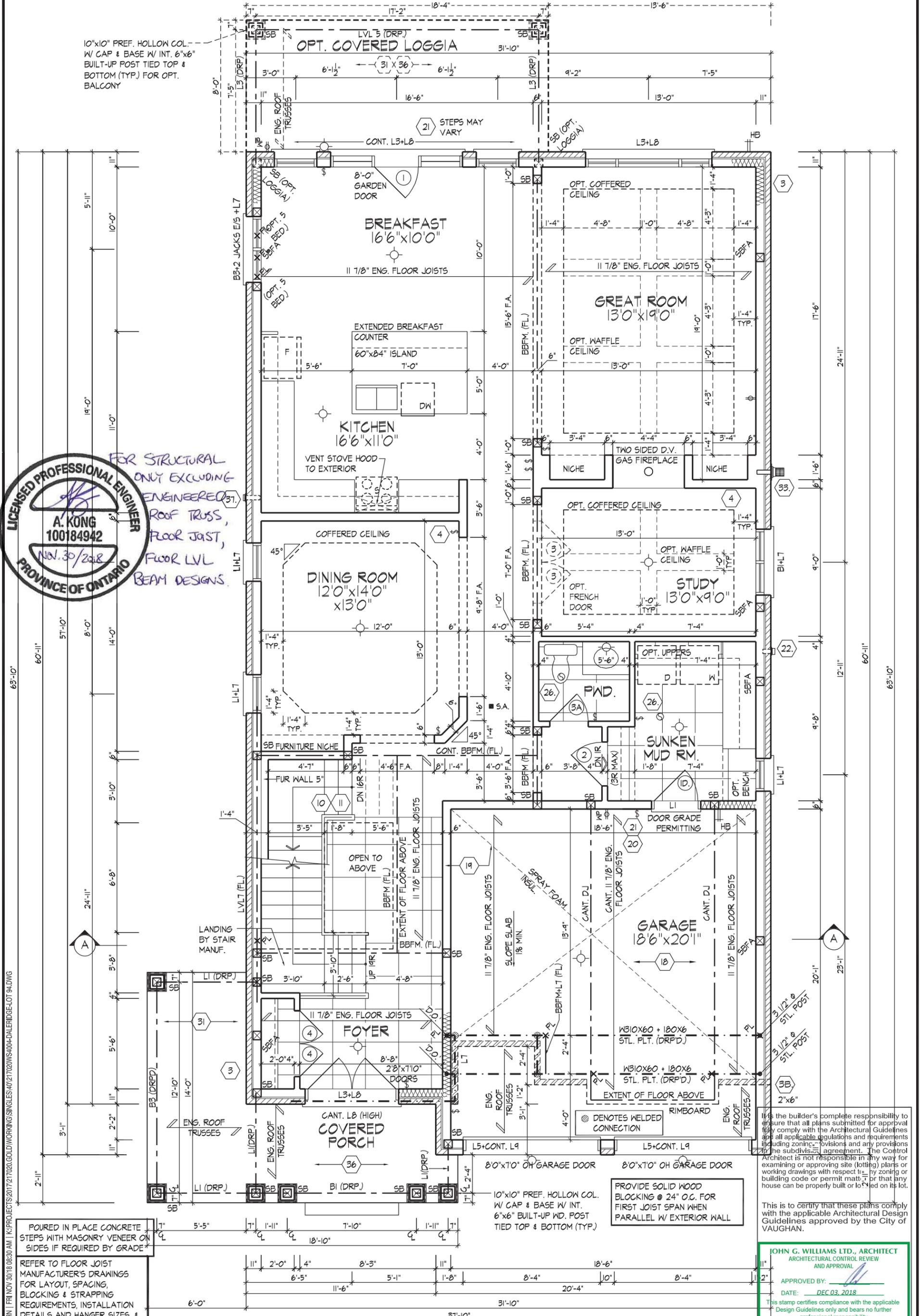

OF: AIPR/BA/RY | FRI NOV 30/18 08:30 AM | K:\PROJECTS\2017\217020.GOLD\WORKING\SINGLES\407217020\WS4004-DALERIDGE-LOT 94.DWG

POURED IN PLACE CONCRETE STEPS WITH MASONRY VENEER ON SIDES IF REQUIRED BY GRADE

REFER TO FLOOR JOIST MANUFACTURER'S DRAWINGS FOR LAYOUT, SPACING, BLOCKING & STRAPPING REQUIREMENTS, INSTALLATION DETAILS AND HANGER SIZES, & SUBFLOOR THICKNESS

10"x10" PREF. HOLLOW COL. W/ CAP & BASE W/ INT. 6"x6" BUILT-UP WD. POST TIED TOP & BOTTOM (TYP.)

PROVIDE SOLID WOOD BLOCKING @ 24" O.C. FOR FIRST JOIST SPAN WHEN PARALLEL W/ EXTERIOR WALL

It is the builder's complete responsibility to ensure that all plans submitted for approval fully comply with the Architectural Guidelines and all applicable regulations and requirements including zoning provisions and any provisions in the subdivision agreement. The Control Architect is not responsible in any way for examining or approving site (lotting) plans or working drawings with respect to zoning or building code or permit matters or that any house can be properly built or located on its lot.

This is to certify that these plans comply with the applicable Architectural Design Guidelines approved by the City of VAUGHAN.

**JOHN G. WILLIAMS LTD., ARCHITECT**  
 ARCHITECTURAL CONTROL REVIEW AND APPROVAL

APPROVED BY: \_\_\_\_\_  
 DATE: DEC 03, 2018

This stamp certifies compliance with the applicable Design Guidelines only and bears no further professional responsibility.

GROUND FLOOR PLAN ELEV. 'A' - LOT 94

GROUND FLOOR PLAN ELEV. 'A' - LOT 94

THE UNDERSIGNED HAS REVIEWED AND TAKES RESPONSIBILITY FOR THIS DESIGN AND HAS THE QUALIFICATIONS AND MEETS THE REQUIREMENTS SET OUT IN THE ONTARIO BUILDING CODE TO BE A DESIGNER.

QUALIFICATION INFORMATION  
 Olin Fairbairn 20201 BCIN

HUNT DESIGN ASSOCIATES INC. 19895

**HUNT DESIGN ASSOCIATES INC.**  
 www.huntdesign.ca

**GOLDPARK HOMES - 217020**  
 PINE VALLEY, VAUGHAN ONT.

Drawn By: HDAL/OF Checked By: OF Scale: 3/16"=1'-0"

**UNIT 4004 - THE DALERIDGE**  
 REV. 2018/11/30

File Number: 217020WS4004-LOT 94 Page Number: 3 of 13

8966 Woodbine Ave, Markham, ON L3R 0J7 T 905.737.5133 F 905.737.7326

All drawings specifications related documents and design are the copyright property of Hunt Design Associates (H.D.A.). Reproduction of this property in whole or in part is strictly prohibited without H.D.A.'s written permission (H.D.A. assumes no responsibility or liability for this property unless it bears the appropriate BCIN number and original signature).



FOR STRUCTURAL ONLY EXCLUDING ENGINEERED ROOF TRUSSES, FLOOR JOIST, FLOOR LVL, BEAM DESIGNS.

ROOF BELOW FOR OPT. LOGGIA

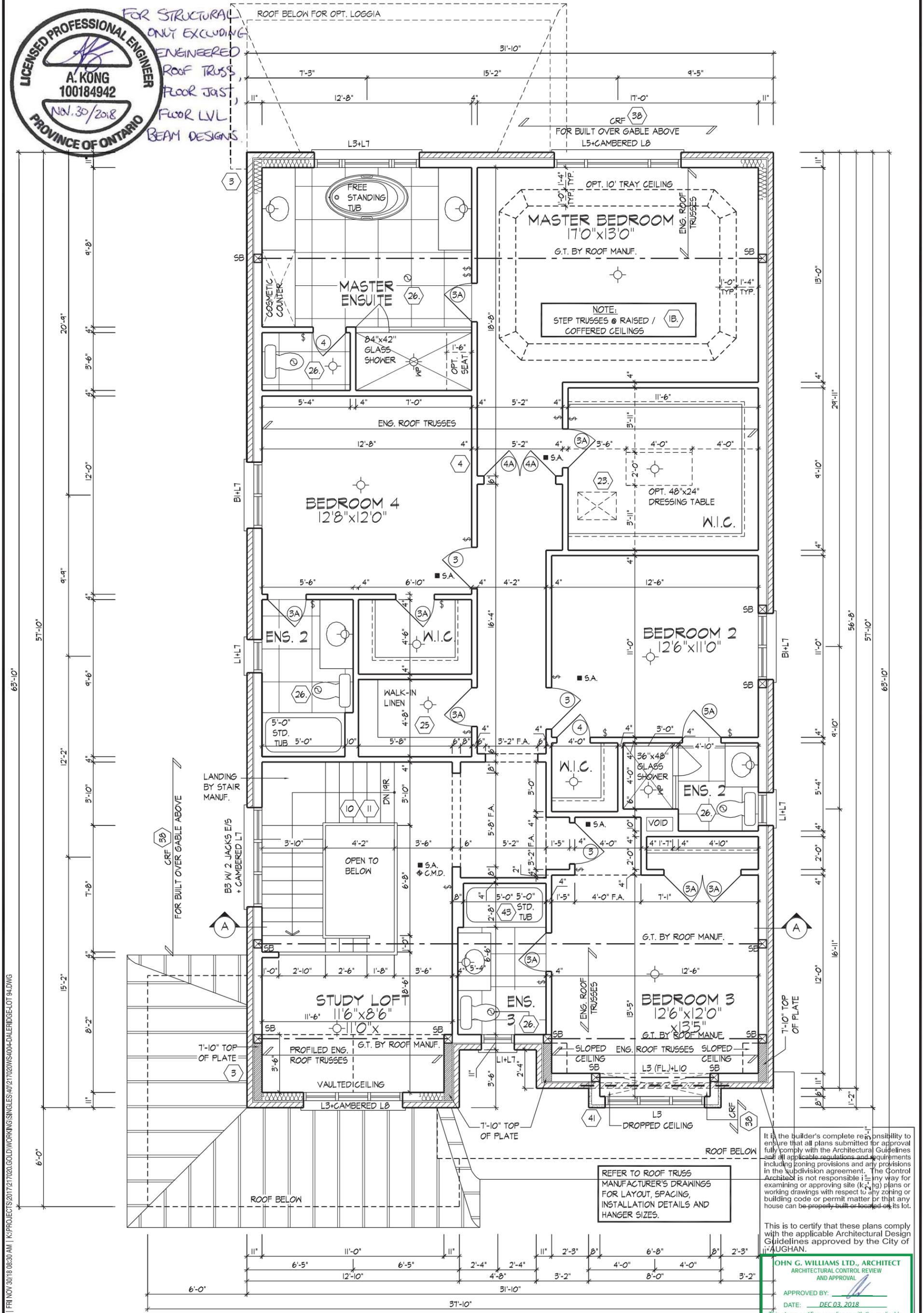

SECOND FLOOR PLAN ELEV. 'A' - LOT 94

SECOND FLOOR PLAN ELEV. 'A' - LOT 94

O:\AIRBARN | FRI NOV 30 18 08:30 AM | K:\PROJECTS\2017\217020.GOLDPARK HOMES\4004-DALERIDGE-LOT 94.DWG

THE UNDERSIGNED HAS REVIEWED AND TAKES RESPONSIBILITY FOR THIS DESIGN AND HAS THE QUALIFICATIONS AND MEETS THE REQUIREMENTS SET OUT IN THE ONTARIO BUILDING CODE TO BE A DESIGNER.  
 QUALIFICATION INFORMATION  
 Olin Fairbairn  
 NAME  
 REGISTRATION INFORMATION  
 HUNT DESIGN ASSOCIATES INC.

*(Signature)*

20201  
BCIN

**HUNT**  
 DESIGN ASSOCIATES INC.  
 www.hunt-design.ca

**GOLDPARK HOMES - 217020**  
 PINE VALLEY, VAUGHAN ONT.

**UNIT 4004 - THE DALERIDGE**  
 REV. 2018/11/30

Drawn By: HDAL/OV    Checked By: OF    Scale: 3/16"=1'-0"    File Number: 217020WS4004-LOT 94    Page Number: 4 of 13  
 8966 Woodbine Ave, Markham, ON L3R 0J7    T 905.737.5133    F 905.737.7326

It is the builder's complete responsibility to ensure that all plans submitted for approval fully comply with the Architectural Guidelines and all applicable regulations and requirements including zoning provisions and any provisions in the subdivision agreement. The Control Architect is not responsible in any way for examining or approving site (k, l, g) plans or working drawings with respect to any zoning or building code or permit matter or that any house can be properly built or located on its lot.

This is to certify that these plans comply with the applicable Architectural Design Guidelines approved by the City of VAUGHAN.

**OHN G. WILLIAMS LTD., ARCHITECT**  
 ARCHITECTURAL CONTROL REVIEW AND APPROVAL  
 APPROVED BY: *(Signature)*  
 DATE: DEC 03, 2018  
 This stamp certifies compliance with the applicable Design Guidelines only and bears no further professional responsibility.

All drawings specifications related documents and design are the copyright property of Hunt Design Associates (H.D.A). Reproduction of this property in whole or in part is strictly prohibited without H.D.A.'s written permission (H.D.A. assumes no responsibility or liability for this property unless it bears the appropriate BCIN number and original signature).



FOR STRUCTURAL ONLY EXCLUDING ENGINEERED ROOF TRUSS, FLOOR JUST, FLOOR LVL BEAM DESIGNS.

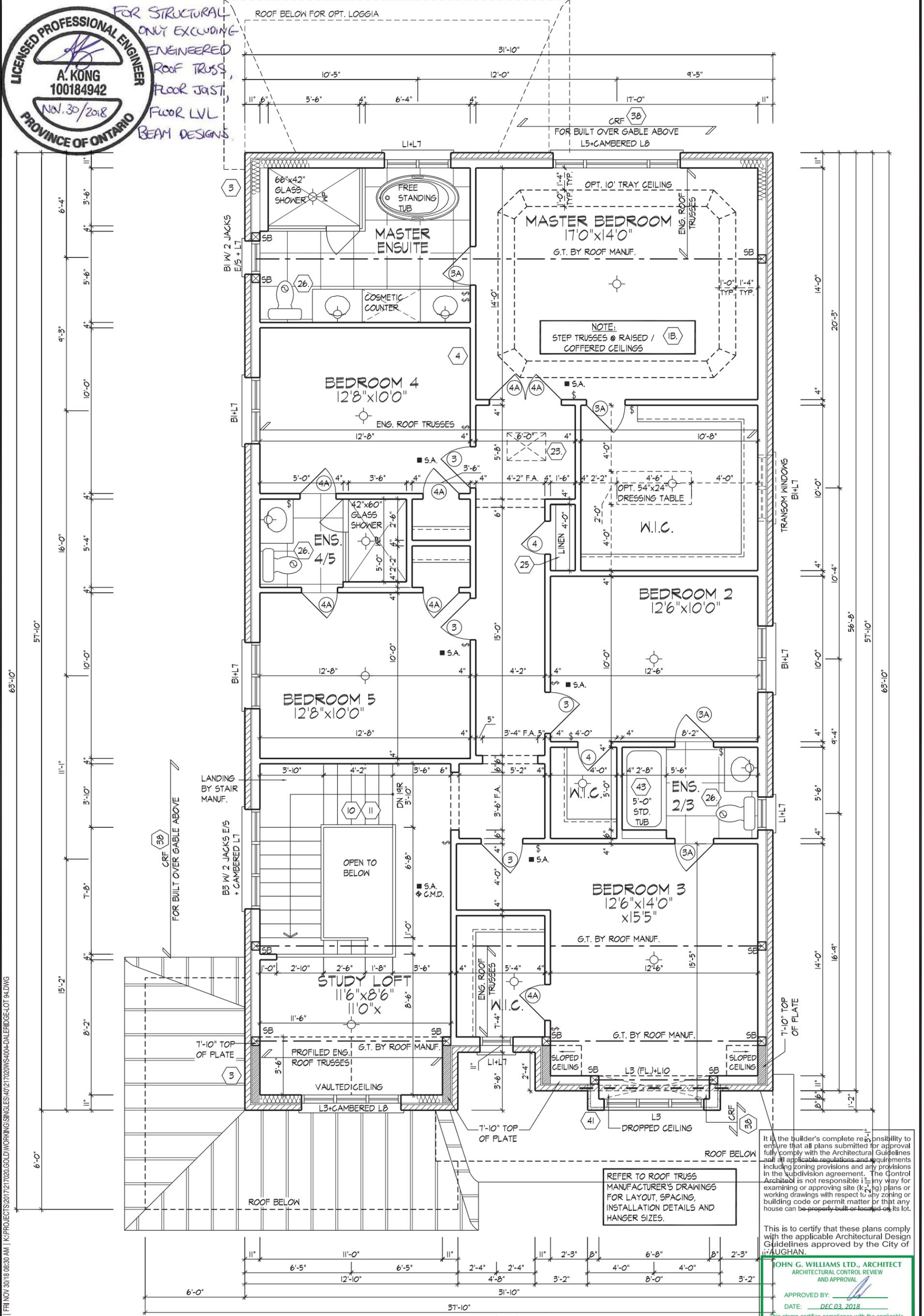

OPT. SECOND FLOOR PLAN ELEV. 'A' W/ 5 BEDROOM - LOT 94

REFER TO ROOF TRUSS MANUFACTURER'S DRAWINGS FOR LAYOUT, SPACING, INSTALLATION DETAILS AND HANGER SIZES.

It is the builder's complete responsibility to ensure that all plans submitted for approval fully comply with the Architectural Guidelines and all applicable regulations and requirements including zoning provisions and any provisions in the subdivision agreement. The Control Architect is not responsible in any way for examining or approving site (k.c.) plans or working drawings with respect to any zoning or building code or permit matter or that any house can be properly built or located on its lot.

This is to certify that these plans comply with the applicable Architectural Design Guidelines approved by the City of Vaughan.

JOHN G. WILLIAMS LTD., ARCHITECT  
 ARCHITECTURAL CONTROL REVIEW  
 AND APPROVAL  
 APPROVED BY: [Signature]  
 DATE: DEC 03, 2018  
 This stamp certifies compliance with the applicable Design Guidelines only and bears no further professional responsibility.

CP:BARBARA | FRI NOV 30 11:08:30 AM | K:\PROJECTS\2017\217020.GOLDPARK HOMES\4004\217020WS4004-DALERIDGE-LOT 94.DWG

THE UNDERSIGNED HAS REVIEWED AND TAKES RESPONSIBILITY FOR THIS DESIGN AND HAS THE QUALIFICATIONS AND MEETS THE REQUIREMENTS SET OUT IN THE ONTARIO BUILDING CODE TO BE A DESIGNER.  
 QUALIFICATION INFORMATION  
 Orlin Fairbairn  
 NAME  
 REGISTRATION INFORMATION  
 HUNT DESIGN ASSOCIATES INC.  
 19695

**HUNT**  
 DESIGN ASSOCIATES INC.  
 www.hunt-design.ca

**GOLDPARK HOMES - 217020**  
**UNIT 4004 - THE DALERIDGE**  
 PINE VALLEY, VAUGHAN ONT.  
 REV. 2018/11/30  
 Drawn By: HDAL/OV  
 Checked By: OF  
 Scale: 3/16"=1'-0"  
 File Number: 217020WS4004-LOT 94  
 Page Number: 5 of 13  
 8966 Woodbine Ave, Markham, ON L3R 0J7 T 905.737.5133 F 905.737.7326

All drawings specifications related documents and design are the copyright property of Hunt Design Associates (H.D.A). Reproduction of this property in whole or in part is strictly prohibited without H.D.A.'s written permission (H.D.A. assumes no responsibility or liability for this property unless it bears the appropriate BCIN number and original signature).

ROOF PLAN,  
EL. 'A'  
N.T.S.

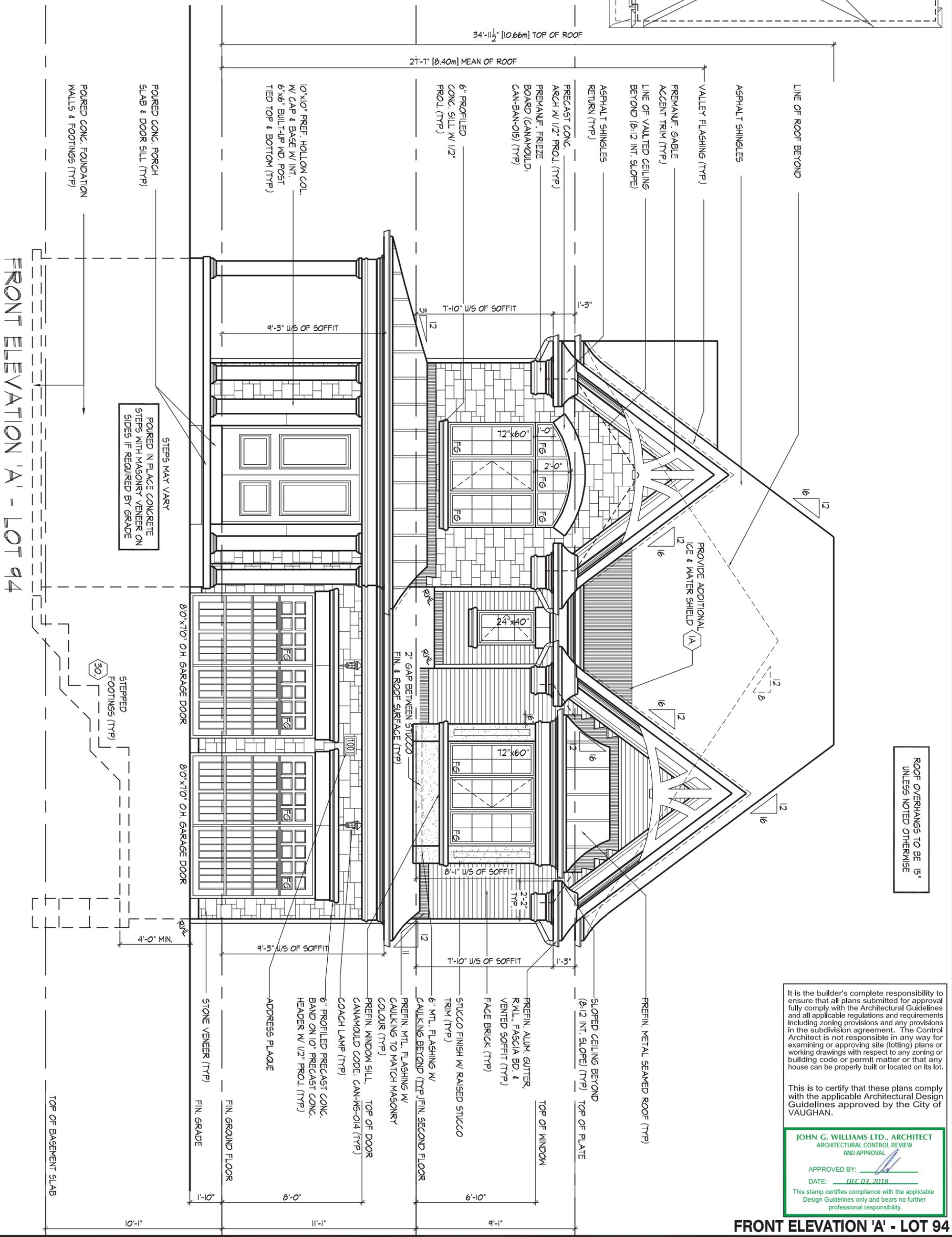
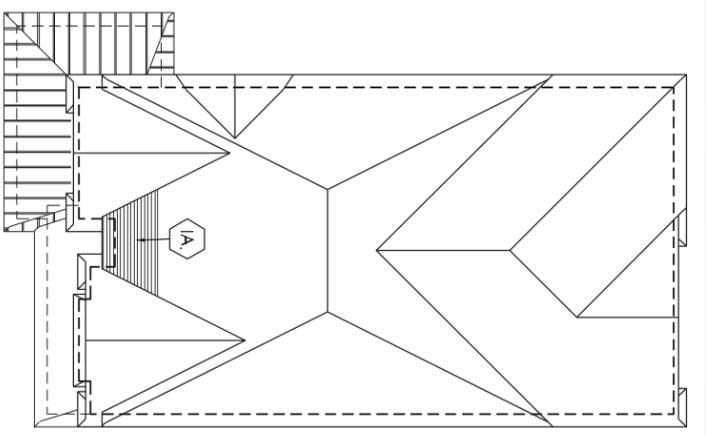

FRONT ELEVATION 'A' - LOT 94

FRONT ELEVATION 'A' - LOT 94

It is the builder's complete responsibility to ensure that all plans submitted for approval fully comply with the Architectural Guidelines and all applicable regulations and requirements including zoning provisions and any provisions in the subdivision agreement. The Control Architect is not responsible in any way for examining or approving site (lotting) plans or working drawings with respect to any zoning or building code or permit matter or that any house can be properly built or located on its lot.

This is to certify that these plans comply with the applicable Architectural Design Guidelines approved by the City of VAUGHAN.

**JOHN G. WILLIAMS LTD., ARCHITECT**  
ARCHITECTURAL CONTROL REVIEW AND APPROVAL

APPROVED BY: \_\_\_\_\_  
DATE: DEC 03, 2018

This stamp certifies compliance with the applicable Design Guidelines only and bears no further professional responsibility.

ROOF OVERHANGS TO BE 15" UNLESS NOTED OTHERWISE

CP:APBARN | FRI NOV 30 11 08:30 AM | K:\PROJECTS\2017\217020.GOLD\WORKING\SINGLES\407217020WS4004-DALERIDGE-LOT 94.DWG

THE UNDERSIGNED HAS REVIEWED AND TAKES RESPONSIBILITY FOR THIS DESIGN AND HAS THE QUALIFICATIONS AND MEETS THE REQUIREMENTS SET OUT IN THE ONTARIO BUILDING CODE TO BE A DESIGNER.

QUALIFICATION INFORMATION  
Orin Fairbairn  
NAME  
REGISTRATION INFORMATION  
HUNT DESIGN ASSOCIATES INC.

20201  
BCIN  
19695

**HUNT**  
DESIGN ASSOCIATES INC.  
www.huntdesign.ca

**GOLDPARK HOMES - 217020**  
PINE VALLEY, VAUGHAN ONT.

Drawn By: HDAL/OV  
Checked By: OF  
Scale: 3/16"=1'-0"

**UNIT 4004 - THE DALERIDGE**  
REV. 2018/11/30

File Number: 217020WS4004-LOT 94  
Page Number: 6 of 13

8966 Woodbine Ave, Markham, ON L3R 0J7 T 905.737.5133 F 905.737.7326

All drawings specifications related documents and design are the copyright property of Hunt Design Associates (H.D.A.). Reproduction of this property in whole or in part is strictly prohibited without H.D.A.'s written permission (H.D.A. assumes no responsibility or liability for this property unless it bears the appropriate BCIN number and original signature).

WINDOW SUMMARY				WINDOW SUMMARY			
PER O.B.C. TABLE 9.10.15.4				PER O.B.C. TABLE 9.10.15.4			
LEFT SIDE ELEV. A				LEFT SIDE ELEV. A-OPT. SEC.FLR			
QUAN.	WIDTH	DEPTH	WINDOW / DOOR FRAME SIZE (S.F.)	QUAN.	WIDTH	DEPTH	WINDOW / DOOR FRAME SIZE (S.F.)
1	48"	52"	14.67	1	48"	52"	14.67
1	24"	48"	6.11	1	48"	52"	14.67
1	72"	60"	26.44	1	72"	60"	26.44
2	28"	68"	21.33	2	28"	68"	21.33
1	48"	68"	19.56	1	24"	48"	6.11
0	0"	0"	0.00	1	48"	68"	19.56
0	0"	0"	0.00	0	0"	0"	0.00
SPATIAL CALCULATION				SPATIAL CALCULATION			
EXPOSING BUILDING				EXPOSING BUILDING			
FACE AREA				FACE AREA			
122.85 S.M.				1322.40 S.F.			
PORTION WALL AREA				PORTION WALL AREA			
122.85 S.M.				1322.40 S.F.			
LIMITING DISTANCE				LIMITING DISTANCE			
7.80 %				7.80 %			
MAX. % OPENINGS				MAX. % OPENINGS			
103.15 S.F.				103.15 S.F.			
OPENINGS ALLOWED				OPENINGS ALLOWED			
88.41 S.F.				102.78 S.F.			
OPENINGS PROVIDED				OPENINGS PROVIDED			
ADDITIONAL NOTES				ADDITIONAL NOTES			
GLAZED AREA CALCULATED W/ FRAME SIZE				GLAZED AREA CALCULATED W/ FRAME SIZE			
MINUS 2' AROUND ENTIRE PERIMETER				MINUS 2' AROUND ENTIRE PERIMETER			

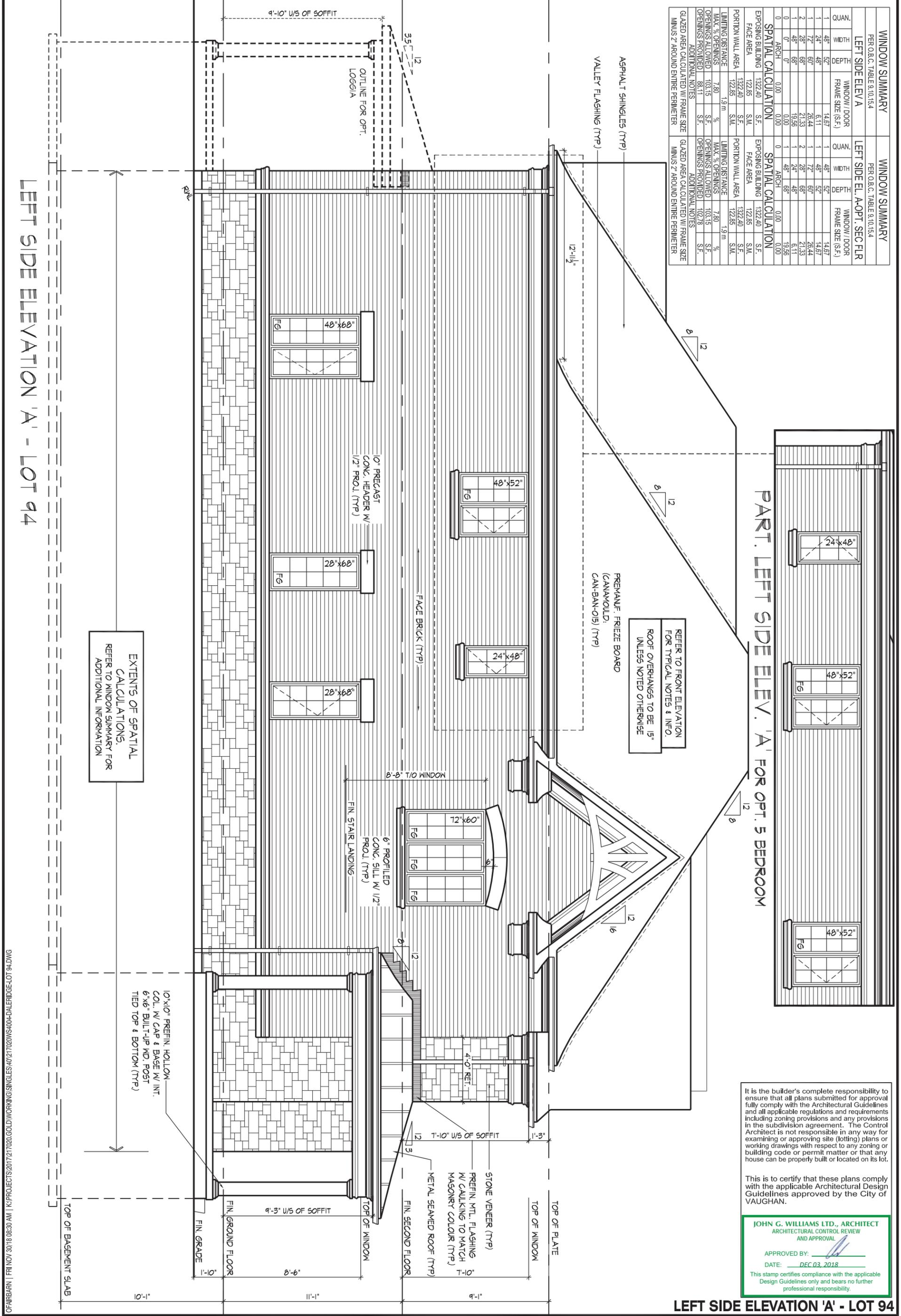

LEFT SIDE ELEVATION 'A' - LOT 94

PART. LEFT SIDE ELEV. 'A' FOR OPT. 5 BEDROOM

EXTENTS OF SPATIAL CALCULATIONS. REFER TO WINDOW SUMMARY FOR ADDITIONAL INFORMATION

REFER TO FRONT ELEVATION FOR TYPICAL NOTES & INFO. ROOF OVERHANGS TO BE 15" UNLESS NOTED OTHERWISE

PERMANENT FRIEZE BOARD (CAN-BAN-015) (TYP)

It is the builder's complete responsibility to ensure that all plans submitted for approval fully comply with the Architectural Guidelines and all applicable regulations and requirements including zoning provisions and any provisions in the subdivision agreement. The Control Architect is not responsible in any way for examining or approving site (lotting) plans or working drawings with respect to any zoning or building code or permit matter or that any house can be properly built or located on its lot.

This is to certify that these plans comply with the applicable Architectural Design Guidelines approved by the City of VAUGHAN.

JOHN G. WILLIAMS LTD., ARCHITECT  
 ARCHITECTURAL CONTROL REVIEW AND APPROVAL  
 APPROVED BY: [Signature]  
 DATE: DEC 03, 2018  
 This stamp certifies compliance with the applicable Design Guidelines only and bears no further professional responsibility.

LEFT SIDE ELEVATION 'A' - LOT 94

THE UNDERSIGNED HAS REVIEWED AND TAKES RESPONSIBILITY FOR THIS DESIGN AND HAS THE QUALIFICATIONS AND MEETS THE REQUIREMENTS SET OUT IN THE ONTARIO BUILDING CODE TO BE A DESIGNER.  
 QUALIFICATION INFORMATION  
 Olin Fairbairn  
 NAME  
 REGISTRATION INFORMATION  
 HUNT DESIGN ASSOCIATES INC.  
 20201  
 BCIN  
 19695

**HUNT**  
 DESIGN ASSOCIATES INC.  
 www.huntdesign.ca

**GOLDPARK HOMES - 217020**  
 PINE VALLEY, VAUGHAN ONT.  
 Drawn By HDAL/OV  
 Checked By OF  
 Scale 3/16"=1'-0"  
 8966 Woodbine Ave, Markham, ON L3R 0J7 T 905.737.5133 F 905.737.7326

**UNIT 4004 - THE DALERIDGE**  
 REV. 2018/11/30  
 File Number 217020WS4004-LOT 94  
 Page Number 7 of 13

All drawings specifications related documents and design are the copyright property of Hunt Design Associates (H.D.A). Reproduction of this property in whole or in part is strictly prohibited without H.D.A.'s written permission (H.D.A. assumes no responsibility or liability for this property unless it bears the appropriate BCIN number and original signature).



WINDOW SUMMARY		
PER O.B.C. TABLE 9.10.15.4		
REAR ELEVATION A		
QUAN.	H. LG. (H)	W. LG. (W)
2	24"	52"
1	48"	52"
2	20"	48"
1	36"	48"
2	24"	72"
1	48"	72"
2	32"	68"
2	30"	16"
1	DOOR	27.52
1	TRANSOM	10.96
0	ARCH	0.00
0	ARCH	0.00

  

SPATIAL CALCULATION		
EXPOSING BUILDING		
FACE AREA	720.50	S.F.
PORTION WALL AREA	66.94	S.M.
LIMITING DISTANCE	7.50	m
MAX. % OPENINGS	50	%
OPENINGS ALLOWED	360.25	S.F.
OPENINGS PROVIDED	154.94	S.F.

REAR ELEV. A-OPT. SEC FLR		
QUAN.	H. LG. (H)	W. LG. (W)
2	24"	52"
1	48"	52"
2	24"	72"
1	48"	72"
2	32"	68"
2	30"	16"
1	DOOR	27.52
1	TRANSOM	10.96
0	ARCH	0.00
0	ARCH	0.00

**PART. REAR ELEVATION 'A'**  
**FOR OPT. 5 BEDROOM**

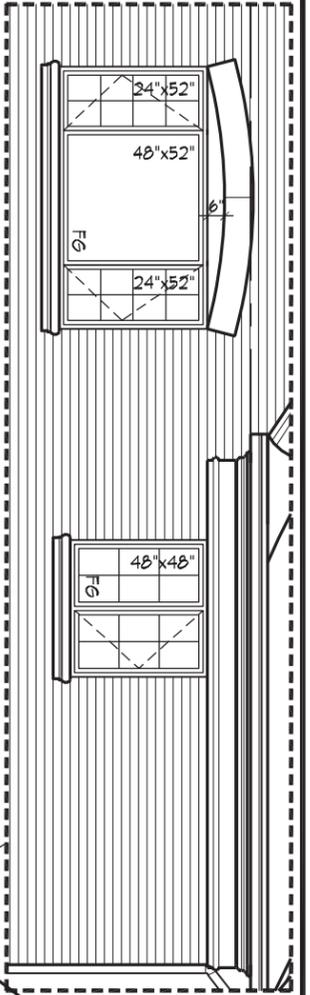

REFER TO FRONT ELEVATION FOR TYPICAL NOTES & INFO. ROOF OVERHANGS TO BE 15" UNLESS NOTED OTHERWISE

It is the builder's complete responsibility to ensure that all plans submitted for approval fully comply with the Architectural Guidelines and all applicable regulations and requirements including zoning provisions and any provisions in the subdivision agreement. The Control Architect is not responsible in any way for examining or approving site (lotting) plans or working drawings with respect to any zoning or building code or permit matter or that any house can be properly built or located on its lot.

This is to certify that these plans comply with the applicable Architectural Design Guidelines approved by the City of VAUGHAN.

**JOHN G. WILLIAMS LTD., ARCHITECT**  
ARCHITECTURAL CONTROL REVIEW AND APPROVAL

APPROVED BY:

DATE: DEC 03, 2018

This stamp certifies compliance with the applicable Design Guidelines only and bears no further professional responsibility.

**REAR ELEVATION 'A' - LOT 94**

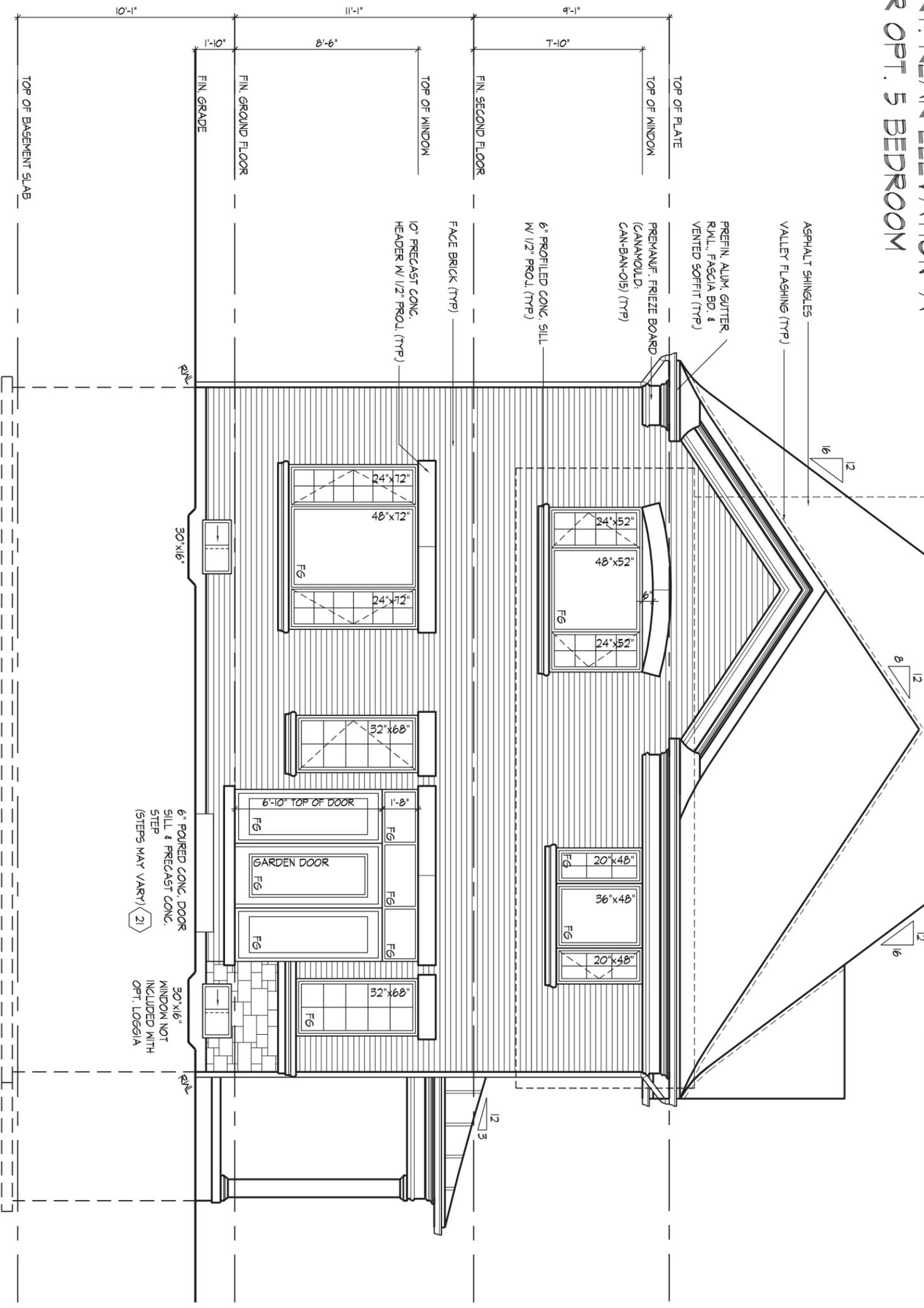

**REAR ELEVATION 'A' - LOT 94**

OP:RBA:RNR | FRI NOV 30 11:08:30 AM | K:\PROJECTS\2017\217020.GOLD\WORKING\SINGLES\407217020\WS4004-DALERIDGE-LOT 94.DWG

THE UNDERSIGNED HAS REVIEWED AND TAKES RESPONSIBILITY FOR THIS DESIGN AND HAS THE QUALIFICATIONS AND MEETS THE REQUIREMENTS SET OUT IN THE ONTARIO BUILDING CODE TO BE A DESIGNER.

QUALIFICATION INFORMATION  
Olin Fairbairn  
SIGNATURE

20201  
BCIN

HUNT DESIGN ASSOCIATES INC. 19895

**HUNT DESIGN ASSOCIATES INC.**  
www.huntdesign.ca

**GOLDPARK HOMES - 217020**  
PINE VALLEY, VAUGHAN ONT.

Drawn By: HDAL/OV  
Checked By: OF  
Scale: 3/16"=1'-0"

**UNIT 4004 - THE DALERIDGE**  
REV. 2018/11/30

File Number: 217020WS4004-LOT 94  
Page Number: 9 of 13

8966 Woodbine Ave, Markham, ON L3R 0J7 T 905.737.5133 F 905.737.7326

All drawings specifications related documents and design are the copyright property of Hunt Design Associates (H.D.A). Reproduction of this property in whole or in part is strictly prohibited without H.D.A.'s written permission (H.D.A. assumes no responsibility or liability for this property unless it bears the appropriate BCIN number and original signature.)

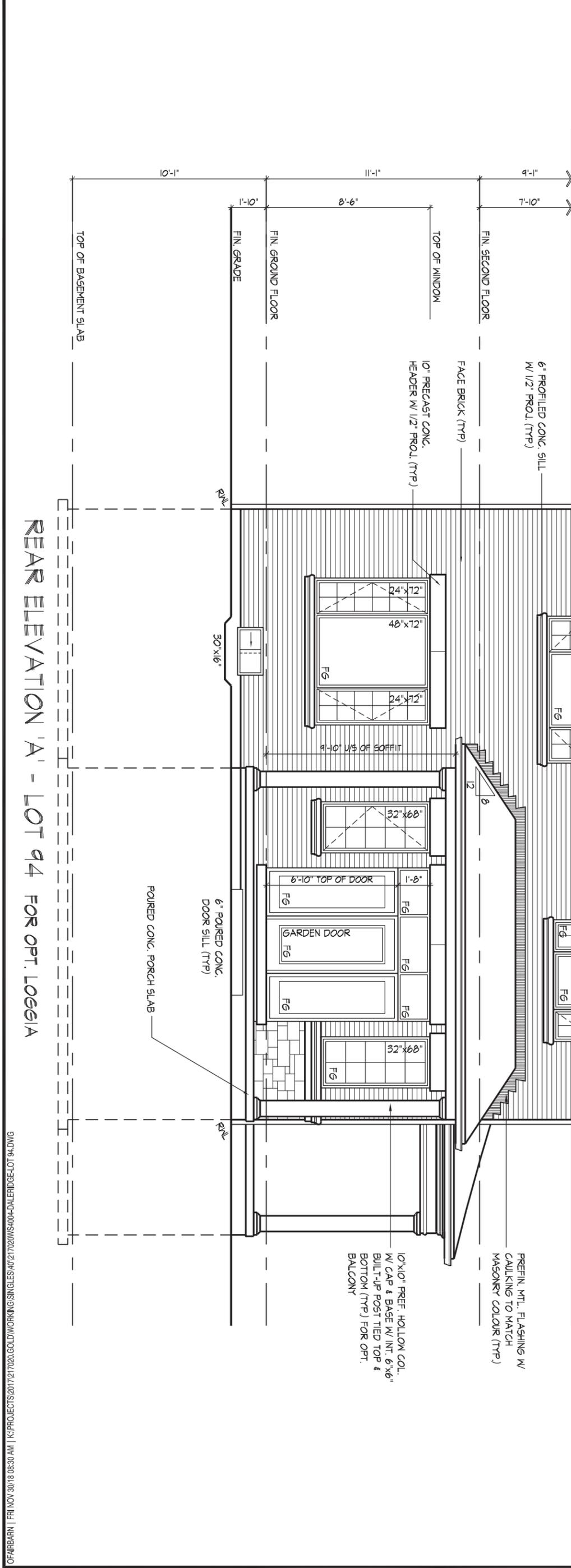

REAR ELEVATION 'A' - LOT 94 FOR OPT. LOGGIA

REFER TO FRONT ELEVATION FOR TYPICAL NOTES & INFO.  
ROOF OVERHANGS TO BE 15" UNLESS NOTED OTHERWISE

It is the builder's complete responsibility to ensure that all plans submitted for approval fully comply with the Architectural Guidelines and all applicable regulations and requirements including zoning provisions and any provisions in the subdivision agreement. The Control Architect is not responsible in any way for examining or approving site (lotting) plans or working drawings with respect to any zoning or building code or permit matter or that any house can be properly built or located on its lot.

This is to certify that these plans comply with the applicable Architectural Design Guidelines approved by the City of VAUGHAN.

**JOHN G. WILLIAMS LTD., ARCHITECT**  
ARCHITECTURAL CONTROL REVIEW AND APPROVAL  
APPROVED BY: \_\_\_\_\_  
DATE: DEC 03, 2018  
This stamp certifies compliance with the applicable Design Guidelines only and bears no further professional responsibility.

**PARTIAL. REAR ELEVATION 'A' FOR OPT. LOGGIA**

THE UNDERSIGNED HAS REVIEWED AND TAKES RESPONSIBILITY FOR THIS DESIGN AND HAS THE QUALIFICATIONS AND MEETS THE REQUIREMENTS SET OUT IN THE ONTARIO BUILDING CODE TO BE A DESIGNER.  
QUALIFICATION INFORMATION  
Orin Fairbairn  
NAME  
REGISTRATION INFORMATION  
HUNT DESIGN ASSOCIATES INC.  
SIGNATURE  
20201  
BCIN  
19895

**HUNT**  
DESIGN ASSOCIATES INC.  
www.huntdesign.ca

**GOLDPARK HOMES - 217020**  
PINE VALLEY, VAUGHAN ONT.  
Drawn By HDAL/OF  
Checked By OF  
Scale 3/16"=1'-0"

**UNIT 4004 - THE DALERIDGE**  
REV. 2018/11/30  
File Number 217020WS4004-LOT 94  
Page Number 10 of 13  
8966 Woodbine Ave, Markham, ON L3R 0J7 T 905.737.5133 F 905.737.7326

All drawings specifications related documents and design are the copyright property of Hunt Design Associates (H.D.A). Reproduction of this property in whole or in part is strictly prohibited without H.D.A.'s written permission (H.D.A. assumes no responsibility or liability for this property unless it bears the appropriate BCIN number and original signature).

CROSS SECTION 'A-A'

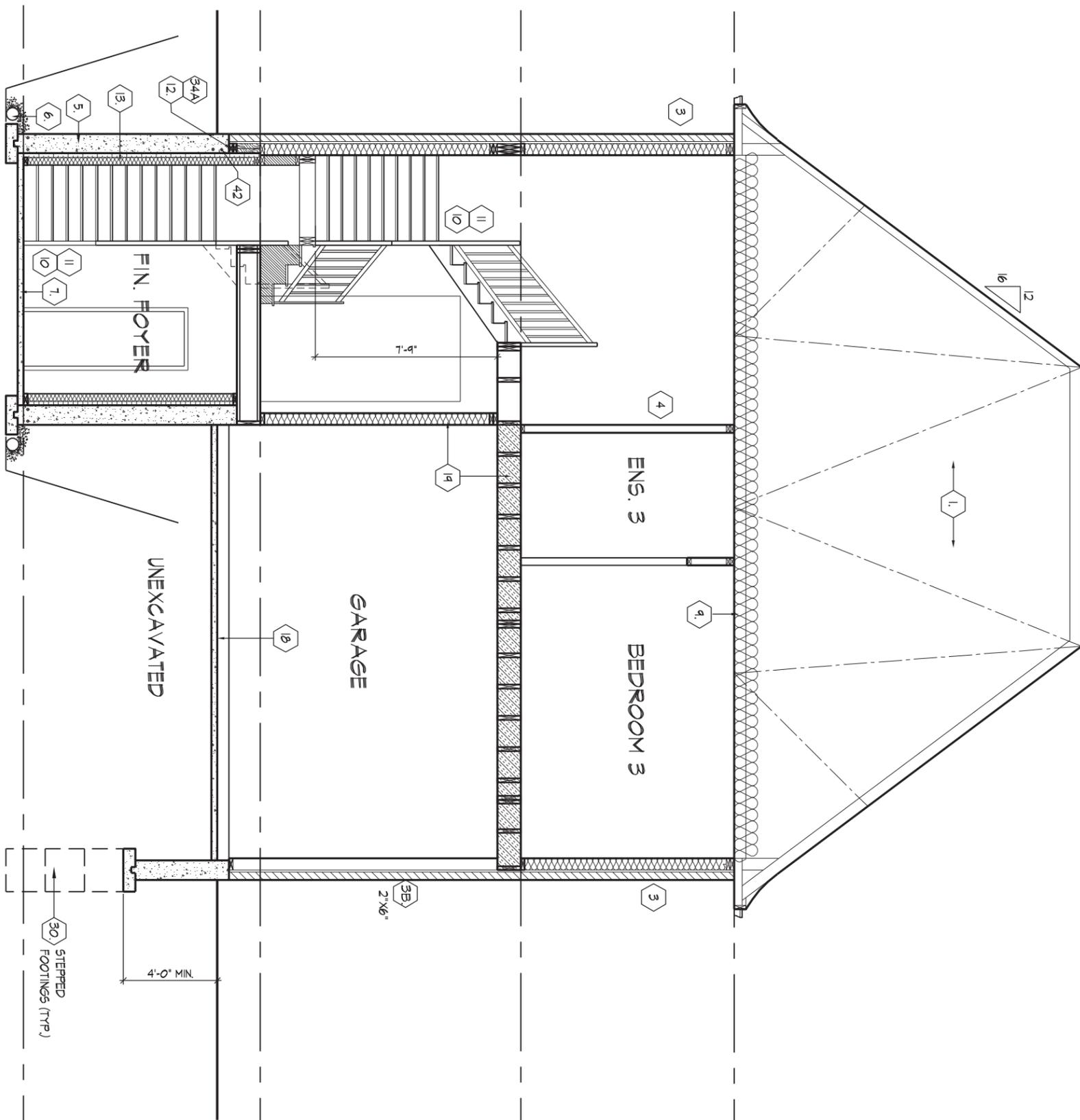

ROOF OVERHANGS TO BE 15"  
UNLESS NOTED OTHERWISE

STAIR SECTION

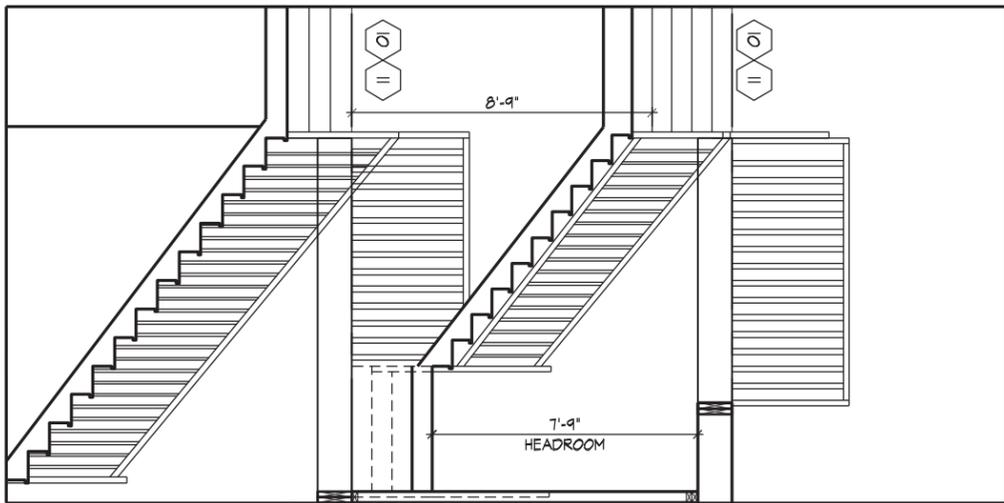

CROSS SECTION 'A-A'

OP:FBARN | FRI NOV 30 11 08:30 AM | K:\PROJECTS\2017\217020.GOLDWORKING\SINGLES\407217020\WS4004-DALERIDGE-LOT 94.DWG

THE UNDERSIGNED HAS REVIEWED AND TAKES RESPONSIBILITY FOR THIS DESIGN AND HAS THE QUALIFICATIONS AND MEETS THE REQUIREMENTS SET OUT IN THE ONTARIO BUILDING CODE TO BE A DESIGNER.  
 QUALIFICATION INFORMATION  
 Orlin Fairbairn  
 NAME: Orlin Fairbairn  
 REGISTRATION INFORMATION: 19695  
 SIGNATURE: [Signature]  
 BCIN: 20201

**HUNT**  
 DESIGN ASSOCIATES INC.  
 www.hunt-design.ca

**GOLDPARK HOMES - 217020**  
 PINE VALLEY, VAUGHAN ONT.  
 Drawn By: HDAI/OF  
 Checked By: OF  
 Scale: 3/16" = 1'-0"

**UNIT 4004 - THE DALERIDGE**  
 REV. 2018/11/30  
 File Number: 217020WS4004-LOT 94  
 Page Number: 11 of 13  
 8966 Woodbine Ave, Markham, ON L3R 0J7 T 905.737.5133 F 905.737.7326

All drawings specifications related documents and design are the copyright property of Hunt Design Associates (H.D.A). Reproduction of this property in whole or in part is strictly prohibited without H.D.A.'s written permission (H.D.A. assumes no responsibility or liability for this property unless it bears the appropriate BCIN number and original signature).

SECTION 1.0. CONSTRUCTION NOTES

REFER TO SB-12 ENERGY EFFICIENCY DESIGN MATRIX ON THE TITLE PAGE FOR ALL VALUES AS REQUIRED PER 3.1.1., 3.1.2., 3.1.3. OF THE OBC.

1 ROOF CONSTRUCTION (9.19., 9.23.13., 9.23.15.) NO. 210 (10.25 KG/M2) ASPHALT SHINGLES, 3/8" (9.5) PLYWOOD SHEATHING WITH "H" CLIPS. APPROVED WOOD TRUSSES @ 24" (610) O.C. MAX. APPROVED EAVES PROTECTION TO EXTEND 2'-11" (900) FROM EDGE OF ROOF AND MIN. 12" (305) BEYOND INNER FACE OF EXTERIOR WALL. 2"x4"(38x89) TRUSS BRACING @ 6'-0" (1830) O.C. AT BOTTOM CHORD. PREFIN. ALUM. EAVESTROUGH, FASCIA, RWL & VENTED SOFFIT. ATTIC VENTILATION 1:300 OF INSULATED CEILING AREA WITH MIN. 25% OR REQUIRED OPENINGS LOCATED AT TOP OF SPACE & MIN. 25% OF REQUIRED OPENINGS LOCATED AT BOTTOM OF SPACE. EAVESTROUGH TO BE 4" MIN. WITH RWL DISCHARGING ONTO CONCRETE SPLASH PADS OR PER MINIMUM REQUIREMENTS. TOWNHOUSES TO HAVE 5" MIN. EAVESTROUGH WITH ELEC. TRACED HEATER CABLE ALONG EAVESTROUGH AND DOWN RWL.

1A ICE AND WATER SHIELD PROVIDE ICE AND WATER SHIELD IN THE AREAS INDICATED. THE ICE AND WATER SHIELD SHALL BE A SELF ADHERING AND SELF SEALING MEMBRANE. SIDE LAPS MUST BE A MINIMUM 3 1/2" (90) AND END LAPS A MINIMUM 6" (152). AND TO EXTEND UP DORMER WALLS A MINIMUM 12" (305).

1B PROFILED ROOF TRUSSES ROOF TRUSSES SHALL BE PROFILED AND/OR STEPPED AT RAISED COFFER/TRAY CEILING. ANGLED TRAY CEILING WILL BE SHEATHED W/ 3/8" (9.5) PLYWOOD.

2 SIDING WALL CONSTRUCTION SIDING MATERIAL AS PER ELEVATION ATTACHED TO FRAMING MEMBERS. FURRING MEMBERS OR BLOCKING BETWEEN THE FRAMING MEMBERS ON APPROVED SHEATHING PAPER ON 3/8" (9.5) EXT. GRADE SHEATHING ON STUDS CONFORMING TO O.B.C (9.23.10.1.) & SECTION 1.1., INSULATION. APPROVED 6 MIL POLYETHYLENE AIR/VAPOUR BARRIER, ON 1/2" (12.7) GYPSUM WALLBOARD INT. FIN. (GYPSUM SHEATHING, RIGID INSULATION, AND FIBERBOARD SHALL NOT BE USED FOR THE ATTACHMENT OF SIDING (9.23.16.3.(1.1)) (REFER TO 35 NOTE AS REQ.)

2A SIDING WALL CONSTRUCTION W/ CONTIN. INSULATION SIDING MATERIAL AS PER ELEVATION ATTACHED TO FURRING MEMBERS ON APPROVED AIR/WATER BARRIER AS PER O.B.C. 9.27.3. ON EXTERIOR TYPE RIGID INSULATION (JOINTS UNTAPED) MECHANICALLY FASTENED AS PER MANUFACTURER'S SPECIFICATIONS ON 3/8" (9.5) EXT. GRADE SHEATHING ON STUDS CONFORMING TO O.B.C (9.23.10.1.) & SECTION 1.1., INSULATION. APPROVED 6 MIL POLYETHYLENE AIR/VAPOUR BARRIER, ON 1/2" (12.7) GYPSUM WALLBOARD INT. FIN. (GYPSUM SHEATHING, RIGID INSULATION, AND FIBERBOARD SHALL NOT BE USED FOR THE ATTACHMENT OF SIDING (9.23.16.3.(1.1)) (REFER TO 35 NOTE AS REQ.)

2B SIDING WALL @ GARAGE CONSTRUCTION SIDING MATERIAL AS PER ELEVATION ATTACHED TO FRAMING MEMBERS. FURRING MEMBERS OR BLOCKING BETWEEN THE FRAMING MEMBERS ON APPROVED SHEATHING PAPER ON 3/8" (9.5) EXTERIOR TYPE SHEATHING ON STUDS CONFORMING TO O.B.C (9.23.10.1.) & SECTION 1.1., 1/2" (12.7) GYPSUM WALLBOARD INTERIOR FINISH. (GYPSUM SHEATHING, RIGID INSULATION AND FIBERBOARD SHALL NOT BE USED FOR THE ATTACHMENT OF SIDING (9.23.16.3.(1.1)) (REFER TO 35 NOTE AS REQ.)

3 BRICK VENEER WALL CONSTRUCTION 3 1/2" (90) BRICK VENEER 1" (25) AIR SPACE, 7/8"x7"x0.03" (22x180x0.76) GALV. METAL TIES @ 16" (400) O.C. HORIZ. 24" (600) O.C. VERT. BONDING AND FASTENING FOR TIES TO CONFORM WITH 9.20.9. ON APPROVED SHEATHING PAPER, 3/8" (9.5) EXTERIOR TYPE SHEATHING, STUDS CONFORMING TO O.B.C (9.23.10.1.) & SECTION 1.1., INSULATION AND 6 mil POLYETHYLENE VAPOUR BARRIER WITH APPROVED CONTIN. AIR BARRIER, 1/2" (12.7) GYPSUM WALLBOARD INTERIOR FINISH. PROVIDE WEEP HOLES @ 32" (800) O.C. BOTTOM COURSE AND OVER OPENINGS. PROVIDE BASE FLASHING UP MIN. 6" (150) BEHIND BUILDING PAPER (9.20.13.6.) (REFER TO 35 NOTE AS REQUIRED)

3A BRICK VENEER WALL CONSTRUCTION W/ CONTIN. INSULATION 3 1/2" (90) BRICK VENEER 1" (25) AIR SPACE, 7/8"x7"x0.03" (22x180x0.76) GALV. METAL TIES @ 16" (400) O.C. HORIZ. 24" (600) O.C. VERT. BONDING AND FASTENING FOR TIES TO CONFORM WITH 9.20.9. ON APPROVED AIR/WATER BARRIER AS PER O.B.C. 9.27.3. ON EXTERIOR TYPE RIGID INSULATION (JOINTS UNTAPED) MECHANICALLY FASTENED AS PER MANUFACTURER'S SPECIFICATIONS. ON 3/8" (9.5) EXTERIOR TYPE SHEATHING, STUDS CONFORMING TO O.B.C (9.23.10.1.) & SECTION 1.1., INSULATION AND 6 mil POLYETHYLENE VAPOUR BARRIER WITH APPROVED CONTIN. AIR BARRIER, 1/2" (12.7) GYPSUM WALLBOARD INTERIOR FINISH. PROVIDE WEEP HOLES @ 32" (800) O.C. BOTTOM COURSE AND OVER OPENINGS. PROVIDE BASE FLASHING UP MIN. 6" (150) OVER RIGID INSULATION (9.20.13.6.) (REFER TO 35 NOTE AS REQUIRED)

3B BRICK VENEER WALL @ GARAGE CONSTRUCTION 3 1/2" (90) BRICK VENEER, 1" (25) AIR SPACE, 7/8"x7"x0.03" (22x180x0.76) GALV. METAL TIES @ 16" (400) O.C. HORIZ. 24" (600) O.C. VERT. BONDING AND FASTENING FOR TIES TO CONFORM WITH 9.20.9. ON APPROVED SHEATHING PAPER, 3/8" (9.5) EXTERIOR TYPE SHEATHING ON STUDS CONFORMING TO O.B.C (9.23.10.1.) & SECTION 1.1., 1/2" (12.7) GYPSUM WALLBOARD INTERIOR FINISH. PROVIDE WEEP HOLES @ 32" (800) O.C. AT BOTTOM COURSE AND OVER OPENINGS. PROVIDE BASE FLASHING UP 6" (150) MIN. BEHIND BUILDING PAPER (9.20.13.6.) (REFER TO 35 NOTE AS REQ.)

4 INTERIOR STUD PARTITIONS (9.23.9.8., 9.23.10) BEARING PARTITIONS SHALL BE A MINIMUM 2"x4" (38x89) @ 16" (406) O.C. FOR 2 STOREY AND 12" (305) O.C. FOR 3 STOREY. NON-BEARING PARTITIONS 2"x4" (38x89) @ 24" (610) O.C. PROVIDE 2"x4" (38x89) BOTTOM PLATE AND 2"x4" (2-38x89) TOP PLATE. 1/2" (12.7) INT. DRYWALL BOTH SIDES OF STUDS. PROVIDE 2"x6" (38x140) STUDS WHERE NOTED. PROVIDE 2"x4" (38x89) @ 24" (610) O.C. LADDER FRAMING WHERE WALLS INTERSECT PERPENDICULAR TO ONE ANOTHER. PROVIDE 2"x4" (38x89) WOOD BLOCKING ON FLAT @ 3'-11" (1194) O.C. MAX. BETWEEN FLOOR JOISTS WHEN NON-LOADBEARING WALLS ARE PARALLEL TO FLOOR JOISTS.

4A EXT. LOFT WALL CONSTRUCTION - NO CLADDING 3/8" (9.5) EXTERIOR TYPE SHEATHING, STUDS CONFORMING TO O.B.C (9.23.10.1.) & SECTION 1.1., INSULATION AND 6 mil POLYETHYLENE VAPOUR BARRIER WITH APPROVED CONT. AIR BARRIER, 1/2" (12.7) GYPSUM WALLBOARD INT. FINISH. (9.23.)

4B EXT. LOFT WALL CONSTRUCTION - NO CLADDING W/ CONTINUOUS INSULATION APPROVED AIR/WATER BARRIER AS PER O.B.C. 9.27.3. ON EXTERIOR TYPE RIGID INSULATION (JOINTS UNTAPED) MECHANICALLY FASTENED AS PER MANUFACTURER'S SPECIFICATIONS. ON 3/8" (9.5) EXTERIOR TYPE SHEATHING, STUDS CONFORMING TO O.B.C (9.23.10.1.) & SECTION 1.1., INSULATION AND 6 mil POLYETHYLENE VAPOUR BARRIER WITH APPROVED CONT. AIR BARRIER, 1/2" (12.7) GYPSUM WALLBOARD INT. FINISH. (9.23.)

5 FOUNDATION WALL/FOOTINGS Poured CONC. FOUNDATION WALL AS PER CHART BELOW ON CONTINUOUS KEYED CONCRETE FOOTING. FOUNDATION WALLS SHALL EXTEND NOT LESS THAN 6" (150) ABOVE FINISHED GRADE. THE OUTSIDE OF THE FOUNDATION SHALL BE DAMPROOFED FROM THE TOP OF THE FOOTING TO FINISHED GRADE AND BRUSH COAT FROM THE TOP TO 2" BELOW GRADE. PROVIDE A DRAINAGE LAYER ON THE OUTSIDE OF THE FOUNDATION WALL. SEAL THE DRAINAGE LAYER AT THE TOP. THE TOP OF THE CONC. FOOTING SHALL BE DAMPROOFED. CONCRETE FOOTINGS SUPPORTING JOIST SPANS GREATER THAN 16'-1" (4900) SHALL BE SIZED IN ACCORDANCE WITH 9.15.3.4 (1), (2) OF THE O.B.C. (REFER TO CHART BELOW FOR RESPECTIVE SIZE). BRACE FOUNDATION WALL PRIOR TO BACKFILLING. ALL FOOTINGS SHALL REST ON NATURAL UNDISTURBED SOIL OF 125kPa S.L.S. OR COMPACTED ENGINEERED FILL WITH MIN. BEARING CAPACITY OF 125kPa S.L.S.. IF SOIL BEARING DOES NOT MEET MINIMUM CAPACITY, ENGINEERED FOOTINGS ARE REQUIRED. ACTUAL SOIL BEARING CAPACITY TO BE VERIFIED WITH SOIL ENGINEERING REPORT. REFER TO CONSTRUCTION DRAWINGS AND DETAILS FOR FOUNDATION WALL STRENGTH AND THICKNESS AND 9.15.4. FOUNDATION WALLS SHALL NOT EXCEED 9'-10" (3.0m) IN UNSUPPORTED HEIGHT UNLESS OTHERWISE NOTED. [9.15.4.2.(1.1)]

Table with columns: UNREINFORCED SOLID CONCRETE FOUNDATION WALLS (9.15.4.2.), MAX. HEIGHT FROM FIN. SLAB TO GRADE, UNSUPPORTED AT TOP, SUPPORTED AT TOP. Rows for 15 MPa and 20 MPa concrete with various wall thicknesses and heights.

\*9" MIN. THICK FOUNDATION WALL IS REQUIRED FOR MASONRY VENEER FINISHED EXTERIOR WALLS WITH CONTINUOUS INSULATION CONDITION, TO PROVIDE MIN. BEARING FOR SILL PLATES, BEAMS AND FLOOR JOIST AS PER 9.23.7.2., 9.23.8.1., & 9.23.9.1. OF THE O.B.C.

Table: MINIMUM STRIP FOOTING SIZES (9.15.3.) UNLESS NOTED OTHERWISE ON PLANS. Columns: NUMBER FLOORS SUPPORTED, SUPPORTING INT. LOAD BEARING MASONRY WALLS, SUPPORTING EXTERIOR, SUPPORTING PARTYWALL. Rows for 1, 2, and 3 floors.

5A FOUNDATION REDUCTION IN THICKNESS FOR MASONRY WHERE THE TOP OF THE FOUNDATION WALL IS REDUCED IN THICKNESS TO PERMIT THE INSTALLATION OF MASONRY EXTERIOR FACING, THE REDUCED SECTION SHALL BE NOT LESS THAN 3 1/2" (90) THICK. THE BRICK VENEER SHALL BE TIED TO THE FOUNDATION WALL WITH CORROSION RESISTANT METAL TIES @ 7/8" (200) VERTICAL AND 2'-11" (889) HORIZONTAL. FILL VOID WITH MORTAR BETWEEN WALL AND BRICK VENEER (9.15.4.7(2)(3) & 9.20.9.4(3))

5B FOUNDATION REDUCTION IN THICKNESS FOR JOISTS WHERE THE TOP OF THE FOUNDATION WALL IS REDUCED IN THICKNESS TO PERMIT THE INSTALLATION OF FLOOR JOISTS, THE REDUCED SECTION SHALL BE NOT MORE THAN 13 3/4" (350) HIGH & NOT LESS THAN 3 1/2" (90) THICK (9.15.4.7(1))

6 WEEPING TILE 4" (100) Ø WEEPING TILE W/ FILTER CLOTH WRAP & 6" (152) CRUSHED STONE COVER (9.14.3.)

7 BASEMENT SLAB OR SLAB ON GRADE (9.16.4.3.) 3" (80) MIN. 25MPa (3600psi) CONC. SLAB ON 4" (100) COARSE GRANULAR FILL, OR 20MPa (2900psi) CONC. WITH DAMPROOFING BELOW SLAB. PROVIDE 1/2" (12.7) IMPERVIOUS BOARD FOR BOND BREAK AT EDGE. (9.13.) WHERE A BASEMENT SLAB IS WITHIN 24" (610) OF THE EXTERIOR GRADE PROVIDE RIGID INSUL. AROUND THE PERIMETER EXTENDING MIN. 24" (610) BELOW GRADE. FOR SLAB ON GRADE CONDITIONS RIGID INSULATION SHALL BE APPLIED TO THE UNDERSIDE OF THE ENTIRE SLAB. ([SB-12] 3.1.1.7.(5) & (6))

8 EXPOSED FLOOR TO EXTERIOR (9.10.17.10., & CAN/ULC-S705.2) PROVIDE SPRAY FOAM INSULATION BETWEEN CANT. JOIST AND INSTALL FIN. SOFFIT OR CLADDING AS PER ELEVATION TO U/S OF EXPOSED CANT. JOIST.

9 EXPOSED CEILING TO EXTERIOR w/ ATTIC (9.25.2.4) INSULATION, 6 mil POLYETHYLENE VAPOUR BARRIER, 1/2" (12.7) GYPSUM BOARD INTERIOR FINISH OR APPROVED EQ.

EXPOSED CEILING TO EXTERIOR w/o ATTIC JOISTS/TRUSSES AS PER PLANS W/ 2"x2" (38x38) PURLINS @ 16" (406) O.C. PERPENDICULAR TO JOISTS (PURLINS NOT REQ. W/ SPRAY FOAM OR ROOF TRUSSES), W/ INSULATION BETWEEN JOIST, 6 mil POLYETHYLENE VAPOUR BARRIER, 1/2" (12.7) GYPSUM BOARD INT. FINISH OR APPROVED EQ. (CAN/ULC-S705.2, 9.19.1., 9.10.17.1)

Table: ALL STAIRS/EXTERIOR STAIRS (9.8.1.2., 9.8.2., 9.8.4.) with columns for MAX. RISE, MIN. RISE, MAX. RUN, MIN. RUN, MAX. TREAD, MIN. TREAD. Rows for Private and Public stairs.

\*\* HEIGHT OVER STAIRS (HEADROOM) IS MEASURED VERTICALLY ACROSS WIDTH OF STAIRS FROM A STRAIGHT LINE TO THE TREAD & LANDING NOSING TO LOWEST POINT ABOVE AND NOT LESS THAN 6'-5" (1950) FOR SINGLE DWELLING UNIT & 6'-8 3/4" (2050) FOR EVERYTHING ELSE. (9.8.2.2.) REQUIRED LANDING IN GARAGE - O.B.C. 9.8.6.2.(3) FOR AN EXTERIOR STAIR SERVING A GARAGE, W/ MORE THAN 3 RISERS, GUARDS, HANDRAILS & STEPS AS PER CONSTRUCTION HEX NOTE 10 & 11.

11 GUARDS/RAILINGS (9.8.7., 9.8.8.) GUARDS TO BE DESIGNED NOT TO FACILITATE CLIMBING AND PROVIDING MAX. OPENING CONFORMING TO O.B.C. 9.8.8.5. & 9.8.8.6. AND BE ABLE TO RESIST LOADS AS PER TABLE 9.8.8.2. GUARD HEIGHTS - O.B.C. 9.8.8. INTERIOR GUARDS: 2'-11" (900) MIN. EXTERIOR GUARDS: 2'-11" (900) MIN. (LESS THAN 5'-11" (1800) TO GRADE) 3'-6" (1070) MIN. (MORE THAN 5'-11" (1800) TO GRADE)

GUARDS FOR EXIT STAIRS: 3'-0" (920) MIN. GUARDS FOR LANDINGS @ EXIT STAIRS: 3'-6" (1070) MIN. GUARDS FOR FLOORS & RAMPS IN GARAGES (SERVICE STAIRS) FLOOR OR RAMP W/O EXTERIOR WALLS THAT IS 23 5/8" (600) OR MORE ABOVE ADJACENT SURFACE REQUIRES CONT. CURB MIN. 6" (150) HIGH, AND GUARD MIN. 3'-6" (1070) HIGH. REQUIRED GUARDS BETWEEN WALKING SURFACE & ADJACENT SURFACE WITH A DIFFERENCE IN ELEVATION MORE THAN 23 5/8" (600) OR ADJACENT SURFACE WITHIN 3'-11" (1200) & WALKING SURFACE W/ A SLOPE MORE THAN 1 IN 12 SHALL BE PROTECTED WITH GUARDS PER CONSTRUCTION HEX NOTE 11. HANDRAIL HEIGHTS - O.B.C. 9.8.7. - REQUIRED AS PER 9.8.7.1.(3) MIN. HEIGHT AT STAIRS OR RAMP: 2'-10" (865) MAX. HEIGHT AT STAIRS OR RAMP: 3'-2" (965) MAX. HEIGHT AT LANDING: 3'-6" (1070) STAIRS OR RAMP MIN. 7'-3" (2200) WIDE: 2'-9" (865) MIN. HEIGHT

12 SILL PLATES 2"x4" (38x89) SILL PLATE WITH 1/2" (12.7) Ø ANCHOR BOLTS 8" (200) LONG, EMBEDDED MIN. 4" (100) INTO CONC. @ 4'-0" (1220) O.C., CAULKING OR GASKET BETWEEN PLATE AND TOP OF FOUNDATION WALL. USE NON-SHRINK GROUT TO LEVEL SILL PLATE WHEN REQUIRED (9.23.7.)

13 BASEMENT INSULATION ([SB-12] 3.1.1.7.) PROVIDE CONTINUOUS BLANKET INSULATION W/ BUILT IN 6 mil POLYETHYLENE VAPOUR BARRIER. INSULATION TO EXTEND NO MORE THAN 8" (200) ABOVE FINISHED BASEMENT FLOOR. DAMPROOFED WITH BUILDING PAPER BETWEEN THE FOUNDATION WALL AND INSULATION UP TO GRADE LEVEL.

14 BEARING STUD PARTITION IN BASEMENT (9.15.3.6., 9.23.10.1.) 2"x4" (38x89) STUDS @ 16" (406) O.C., 2"x4" (38x89) SILL PLATE (2"x6" (38x140) AS REQUIRED) ON DAMPROOFING MATERIAL OR 2 mil POLYETHYLENE FILM, 1/2" (12.7) Ø ANCHOR BOLTS 8" (200) LONG, EMBEDDED 4" (100) MIN. INTO CONC. @ 7'-10" (2390) O.C. 4" (100) HIGH CONC. CURB ON CONC. FOOTING. FOR SIZE REFER TO HEX NOTE 5. ADD HORIZ. BLOCKING AT MID-HEIGHT IF WALL IS UNFINISHED.

15 ADJUSTABLE STEEL BASEMENT COLUMN (9.15.3.4) 9'-10" (3000) MAX. SPAN BETWEEN COLUMNS, 3 1/2" (90) Ø SINGLE TUBE ADJUSTABLE STEEL COLUMN CONFORMING TO CAN/GS8-7.2M, AND WITH 6"x6"x3/8" (152x152x9.5) STEEL PLATE TOP & BOTTOM. FIELD WELD BASEMENT COLUMN CONNECTION. POURED CONCRETE FOOTING ON NATURAL UNDISTURBED SOIL OF 125kPa S.L.S. OR COMPACTED ENGINEERED FILL WITH MIN. BEARING CAPACITY OF 125kPa S.L.S. AS PER SOILS REPORT. SUPPORTING 2 STOREY FLR. LOAD PROVIDE 34"x34"x16" (870x870x410) CONC. FOOTING SUPPORTING 3 STOREY FLR. LOAD PROVIDE 40"x40"x19" (1060x1060x480) CONC. FOOTING

15A NON-ADJUSTABLE STEEL BASEMENT COLUMN 3 1/2" (90) Ø x 0.188" (4.78) NON-ADJUSTABLE STEEL COLUMN WITH 6"x6"x3/8" (152x152x9.5) STEEL PLATE TOP & BOTTOM. BOTTOM PLATE C/W 2 1/2" Ø x 12" LONG x2" HOOK ANCHORS. FIELD WELD BASEMENT COLUMN CONNECTION. POURED CONCRETE FOOTING ON NATURAL UNDISTURBED SOIL OF 125kPa S.L.S. OR COMPACTED ENGINEERED FILL WITH MIN. BEARING CAPACITY OF 125kPa S.L.S. AS PER SOILS REPORT. SUPPORTING 2 STOREY FLR. LOAD PROVIDE 42"x42"x18" (1070x1070x460) CONC. FOOTING SUPPORTING 3 STOREY FLR. LOAD PROVIDE 48"x48"x24" (1220x1220x610) CONC. FOOTING

15B NON-ADJUSTABLE STL. COLUMN AT FOUNDATION WALL 3 1/2" (90) Ø x 0.188" (4.78) NON-ADJUSTABLE STEEL COLUMN WITH 6"x6"x3/8" (152x152x9.5) STEEL TOP PLATE & 6"x4"x3/8" (152x100x9.5) BOTTOM PLATE. BASE PLATE 4-1/2"x10"x1/2" (120x250x12.7) WITH 2- 1/2" Ø x 12" LONG x 2" HOOK ANCHORS (2- 12.70x305x50). FIELD WELD COLUMN TO BASE PLATE & STEEL BM.

16 STEEL BEAM BEARING AT FOUNDATION WALL (9.23.8.1.) BEAM POCKET OR 8"x8" (200x200) POURED CONC. NIB WALLS, MIN. BEARING 3 1/2" (90).

17 WOOD STRAPPING AT STEEL BEAMS (9.23.4.3.(3), 9.23.9.3.) 1"x3" (19x64) CONTIN. WOOD STRAPPING BOTH SIDES OF STEEL BEAM.

18 GARAGE SLAB (9.16., 9.35.) 4" (100) 32MPa (4640psi) CONC. SLAB WITH 5-8% AIR ENTRAINMENT ON OPT. 4" (100) COARSE GRANULAR FILL WITH COMPACTED SUB-BASE OR COMPACTED NATIVE FILL. SLOPE TO FRONT @ 1% MIN.

19 GARAGE TO HOUSE WALLS/CEILING (9.10.9.16.) 1/2" (12.7) GYPSUM BOARD ON WALL AND CEILING BETWEEN HOUSE AND GARAGE. PLUS REQUIRED INSULATION IN WALLS AND SPRAY FOAM FOR CEILINGS. TAPE AND SEAL ALL JOINTS GAS TIGHT. (9.10.17.10, CAN/ULC-S705.2)

19A GARAGE TO HOUSE WALLS/CEILING W/ CONTIN. INSULATION 1/2" (12.7) GYPSUM BOARD ON CEILING AND ON WALLS INSTALLED OVER EXTERIOR TYPE RIGID INSULATION (JOINTS UNTAPED) MECHANICALLY FASTENED AS PER MANUFACTURER'S SPECIFICATIONS ON 3/8" EXTERIOR GRADE SHEATHING ON STUDS BETWEEN HOUSE AND GARAGE, PLUS REQUIRED INSULATION IN WALLS & SPRAY FOAM FOR CEILINGS. TAPE AND SEAL ALL JOINTS GAS TIGHT. (9.10.9.16., 9.10.17.10, CAN/ULC-S705.2)

20 GARAGE DOOR TO HOUSE (9.10.9.16., 9.10.13.10., 9.10.13.15.) GAS-PROOF DOOR AND FRAME. DOOR EQUIPPED WITH SELF CLOSING DEVICE AND WEATHER STRIPPING.

21 EXTERIOR AND GARAGE STEPS PRECAST CONC. STEP OR WOOD STEP WHERE NOT EXPOSED TO WEATHER. MAX RISE 7/8" (200). MIN. TREAD 9 1/4" (235). FOR THE REQUIRED NUMBER OF STEPS REFER TO SITING AND GRADING DRAWINGS. EXTERIOR CONCRETE STAIRS WITH MORE THAN 2 RISERS AND 2 TREADS SHALL BE PROVIDED WITH FOUNDATION AS REQUIRED BY ARTICLE 9.8.9.2. OR SHALL BE CANTILEVERED AS PER SUBSECTION 9.8.10.

22 DRYER EXHAUST CAPPED DRYER EXHAUST VENTED TO EXT. CONFORMING TO PART 6, OBC 9.32.

23 ATTIC ACCESS (9.19.2.1.) ATTIC ACCESS HATCH WITH MIN. AREA OF 0.32m2 AND NO DIM. LESS THAN 21 1/2" (545) WITH WEATHER STRIPPING. HATCHWAYS TO THE ATTIC OR ROOF SPACE WILL BE FITTED WITH DOORS OR COVERS AND WILL BE INSULATED WITH MIN. R20 (RSI 3.52) ([SB-12] 3.1.1.8.(1))

24 FIREPLACE CHIMNEYS (9.21.) TOP OF FIREPLACE CHIMNEY SHALL BE 2'-11" (889) ABOVE THE HIGHEST POINT AT WHICH IT COMES IN CONTACT WITH THE ROOF AND 2'-0" (610) ABOVE THE ROOF SURFACE WITHIN A HORIZ. DISTANCE OF 10'-0" (3048) FROM THE CHIMNEY.

25 LINEN CLOSET PROVIDE 4 SHELVES MIN. 14" (356) DEEP.

26 MECHANICAL VENTILATION (9.32.1.3.) MECHANICAL EXHAUST FAN, VENTED TO EXTERIOR, TO PROVIDE AT LEAST ONE AIR CHANGE PER HOUR. SEE GENERAL NOTE 2.3.

27 PARTY WALL BEARING (9.23.8) 12"x12"x5/8" (305x305x15.9) STEEL PLATE FOR STEEL BEAMS AND 12"x12"x1/2" (305x305x12.7) STEEL PLATE FOR WOOD BEAMS BEARING (MIN. 3-1/2" (89) ON CONC. BLOCK PARTY WALL, ANCHORED WITH 2-3/4" (2-19) x 8" (200) LONG GALV. ANCHORS WITHIN SOLID BLOCK COURSE. LEVEL W/ NON-SHrink GROUT. REFER TO NOTE SOLID BEARING (SECTION 3.0) FOR WD. STUD PARTY WALL.

28 WOOD FRAMING IN CONTACT TO CONCRETE WOOD BEARING WALLS, THE UNDERSIDE OF BUILT-UP WOOD POSTS AND SILLS SHALL BE WRAPPED WITH 2 mil POLY. STRIP FOOTINGS SUPPORTING THE FOUNDATION WALL SHALL BE WIDENED 6" (152) BELOW THE BEARING WALL AND/OR WOOD POST. (9.17.4.3.)

29 BUILT-UP WOOD POST AND FOOTING (9.17.4.1., 9.15.3.7.) 3-2"x6" (3-38x140) BUILT-UP WOOD POST (UNLESS OTHERWISE NOTED) ON METAL BASE SHOE ANCHORED TO CONC. WITH 1/2" (12.7) Ø BOLT, 24"x24"x12" (610x610x305) CONC. FOOTING OR AS PROVIDED ON PLAN. REFER TO NOTE 28

30 STEP FOOTINGS (9.15.3.9.) MIN. HORIZ. STEP = 23 5/8" (600). MAX. VERT. STEP = 23 5/8" (600).

31 CONC. PORCH SLAB (9.16.4.) MIN. 4" (100) CONCRETE SLAB ON GRADE ON 4" (100) COARSE GRANULAR FILL. REINFORCED WITH 6x6xW2.9xW2.9 MESH PLACED NEAR MID-DEPTH OF SLAB. CONC. STRENGTH 32MPa (4640psi) WITH 5-8% AIR ENTRAINMENT ON COMPACTED SUB-GRADE.

32 FURNACE VENTING (9.32.) DIRECT VENT FURNACE TERMINAL MIN. 3'-0" (915) FROM A GAS REGULATOR. MIN. 12" (305) ABOVE FIN. GRADE, FROM ALL OPENINGS, EXHAUST AND INTAKE VENTS. HRV INTAKE TO BE A MIN. OF 6'-0" (1830) FROM ALL EXHAUST TERMINALS. REFER TO GAS UTILIZATION CODE.

33 FIREPLACE VENTING (9.32.3.) DIRECT VENT GAS FIREPLACE VENT TO BE A MIN. 12" (305) FROM ANY OPENING AND ABOVE FIN. GRADE. REFER TO GAS UTILIZATION CODE.

34 FLOOR FRAMING (9.23.3.5., 9.23.9.4., 9.23.14.) T&G SUBFLOOR ON WOOD FLOOR JOISTS. FOR CERAMIC TILE APPLICATION SEE O.B.C. 9.30.6. ALL JOISTS WHERE REQUIRED TO BE BRIDGED WITH 2"x2" (38x38) CROSS BRACING OR SOLID BLOCKING @ 6'-11" (2108) O.C. MAX. ALL JOISTS TO BE STRAPPED WITH 1"x3" (19x64) @ 6'-11" (2108) O.C. UNLESS A PANEL TYPE CEILING FINISH IS APPLIED.

34A HEADER CONSTRUCTION PROVIDE CONTINUOUS APPROVED AIR/VAPOUR BARRIER (HEADER WRAP) UNDER THE SILL PLATE, AROUND THE RIM BOARD AND UNDER THE BOTTOM PLATE. THE HEADER WRAP SHALL EXTEND 6" (152) BELOW THE TOP OF FOUNDATION WALL AND WILL BE SEALED TO THE CONCRETE FOUNDATION WALL. EXTEND HEADER WRAP 6" (152) UP THE INTERIOR SIDE OF THE STUD WALL AND OVERLAP WITH THE VAPOUR BARRIER AND SEAL THE JOINT. ALL EDGES/JOINTS MUST BE MECHANICALLY CLAMPED.

35 EXPOSED BUILDING FACE w/ LIMITING DISTANCE <= 3'-11" (1.20m) WALL ASSEMBLY CONTAINS INSULATION CONFORMING TO CAN/ULC-S702 & HAVING A MASS OF NOT LESS THAN 1.22 KG/M2 OF WALL SURFACE AND 1/2" (12.7) TYPE X GYPSUM WALLBOARD INTERIOR FINISH. EXTERIOR CLADDING MUST BE NON-COMBUSTIBLE WHEN LIMITING DISTANCE IS 23 5/8" (600) OR LESS. WALL ASSEMBLY REQUIRES TO HAVE A FIRE RESISTANCE RATING OF NOT LESS THAN 45 MINUTES & CONFORMING TO O.B.C. (9.10.14. OR 9.10.15.). REFER TO DETAILS FOR TYPE & SPECS. \*\* AN OPENING IN AN EXPOSING BUILDING FACE NOT MORE THAN 20 in² (130cm²) SHALL NOT BE CONSIDERED AN UNPROTECTED OPENING AS PER 9.10.14.6.

36 COLD CELLAR PORCH SLAB (9.39.) FOR MAX. 8'-2" (2500) PORCH DEPTH, 5" (127) 32 MPa (4640psi) CONC. SLAB W/ 5-8% AIR ENTRAINMENT. REINF. WITH 10M BARS @ 7 7/8" (200) O.C. EACH DIRECTION. W/ 1 1/4" (32) CLEAR COVER FROM BOTTOM OF SLAB TO FIRST LAYER OF BARS & SECOND LAYER OF BARS Laid DIRECTLY ON TOP OF LOWER LAYER IN OPPOSITE DIR. 24"x24" (610x610) 10M DOWELS @ 23 5/8" (600) O.C., ANCHORED IN PERIMETER FND. WALLS. SLOPE SLAB 1.0% FROM DOOR.

37 RANGE HOODS AND RANGE-TOP FANS COOKING APPLIANCE EXHAUST FANS VENTED TO EXTERIOR MUST CONFORM TO OBC 9.10.22, 9.32.3.9., & 9.32.3.10.

38 CONVENTIONAL ROOF FRAMING (9.23.13., 9.23.15.) 2"x6" (38x140) RAFTERS @ 16" (406) O.C., 2"x8" (38x184) RIDGE BOARD, 2"x4" (38x89) COLLAR TIES AT MID-SPAN, CEILING JOISTS TO BE 2"x4" (38x89) @ 16" (406) O.C. FOR MAX. 9'-3" (2819) SPAN & 2"x6" (38x140) @ 16" (406) O.C. FOR MAX. SPAN 14'-7" (4450). RAFTERS FOR BUILT UP ROOF OVER PRE-ENGINEERED ROOF TRUSSES AND OR CONVENTIONAL FRAMING TO BE 2"x4" (38x89) @ 24" (610) O.C. UNLESS OTHERWISE SPECIFIED.

39 TWO STOREY VOLUME SPACES (9.23.10.1., 9.23.11., 9.23.16.)

Table: WALL ASSEMBLY WIND LOADS. Columns: EXTERIOR, STUDS, SPACING, MAX HEIGHT, SPACING, MAX HEIGHT. Rows for Brick, Siding, Brick, Siding with various stud sizes and spacings.

\*\* STUD SIZE & SPACING TO BE VERIFIED BY STRUCTURAL ENGINEER \*\*

STUDS ARE TO BE CONTINUOUS, C/W 3/8" (9.5) THICK EXTERIOR PLYWOOD SHEATHING. PROVIDE SOLID WOOD BLOCKING BETWEEN WOOD STUDS @ 4'-0" (1220) O.C. VERTICALLY.

- FOR HORIZ. DISTANCES LESS THAN 9'-6" (2896) PROVIDE 2"x6" (38x140) STUDS @ 16" (406) O.C. WITH CONTIN. 2-2"x6" (2-38x140) TOP PLATE + 1-2"x6" (1-38x140) BOTTOM PLATE & MIN. OF 3-2"x8" (3-38x184) CONT. HEADER AT GROUND FLOOR CEILING LEVEL TOE-NAILED & GLUED AT TOP, BOTTOM PLATES & HEADERS.

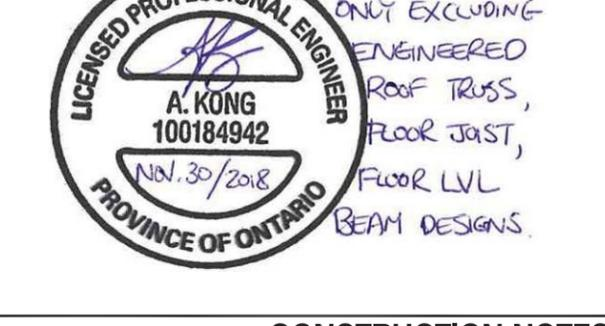

CONSTRUCTION NOTES

Project information block including: THE UNDERSIGNED HAS REVIEWED AND TAKES RESPONSIBILITY FOR THIS DESIGN AND HAS THE QUALIFICATIONS AND MEETS THE REQUIREMENTS SET OUT IN THE ONTARIO BUILDING CODE TO BE A DESIGNER. QUALIFICATION INFORMATION: Oin Fairban, 20201. NAME: HUNT DESIGN ASSOCIATES INC., REGISTRATION INFORMATION: 19695. HUNT DESIGN ASSOCIATES INC. 19695. GOLDPARK HOMES - 217020 PINE VALLEY, VAUGHAN ONT. Drawn By: HD/1/OF, Checked By: OF, Scale: 3/16"=1'-0", File Number: 217020WS4004-LOT 94, Page Number: 12 of 13. www.huntdesign.ca 8966 Woodbine Ave, Markham, ON L3R 0J7 T 905.737.5133 F 905.737.7326

All drawings specifications related documents and design are the copyright property of Hunt Design Associates (H.D.A). Reproduction of this property in whole or in part is strictly prohibited without H.D.A.'s written permission (H.D.A. assumes no responsibility or liability for this property unless it bears the appropriate BCIN number and original signature.)

cont. SECTION 1.0. CONSTRUCTION NOTES

40 1 HR. PARTY WALL (CONC. BLOCK) ((SB-3) WALL TYPE 'B6e' & 'B1b') 1/2" (12.7) GYPSUM SHEATHING ON EACH SIDE ON 2"x2" (38x38) VERTICAL WD. STRAPPING @ 24" (610) O.C. ON 8" (200) CONC. BLOCK FILL STRAPPING CAVITY EACH SIDE WITH AT LEAST 90% OF ABSORPTIVE MATERIAL PROCESSED FROM ROCK, SLAG OR GLASS, TAPE, FILL & SAND ALL GYPSUM JOINTS. EXPOSED BLOCK MUST BE SEALED W/ 2 COATS OF PAINT OR FURRED WITH 2"x2" (38x38) WD. STRAPPING & 1/2" (12.7) GYPSUM SHEATHING.

40 DEL. STUO 1 HR. PARTY WALL (DOUBLE STUD) ((SB-3) WALL TYPE 'W13c') 5/8" (15.9) TYPE 'X' GYPSUM SHEATHING ON EXTERIOR SIDE OF 2 ROWS OF 2"x4" (38x89) STUDS @ 16" (406) O.C., MIN. 1" (25) APART ON SEPARATE 2"x4" (38x89) SILL PLATES. (2"x6" (38x140) AS REQUIRED) FILL ONE SIDE OF STUD CAVITY WITH AT LEAST 90% OF ABSORPTIVE MATERIAL PROCESSED FROM ROCK, SLAG OR GLASS, TAPE FILL AND SAND ALL GYPSUM JOINTS.

40A 2 HR. FIREWALL ((SB-3) WALL TYPE 'B6e' & 'B1b') 1/2" (12.7) GYPSUM SHEATHING ON EACH SIDE ON 2"x2" (38x38) VERTICAL WOOD STRAPPING @ 24" (610) O.C. ON 8" (200) CONC. BLOCK 75% SOLID. FILL STRAPPING CAVITY EACH SIDE WITH AT LEAST 90% OF ABSORPTIVE MATERIAL PROCESSED FROM ROCK, SLAG OR GLASS, TAPE, FILL & SAND ALL GYPSUM JOINTS. AT UNFINISHED AREAS, EXTERIOR FACE OF CONC. BLOCK TO BE SEALED WITH 2 COATS OF PAINT. GYPSUM SHEATHING TO BE ATTACHED TO CONC. BLOCK. (REFER TO DETAILS)

41 STUCCO WALL CONSTRUCTION STUCCO FINISH CONFORMING TO O.B.C. SECTION 9.28. AND APPLIED PER MANUFACTURERS SPECIFICATIONS OVER 1 1/2" (38) E.I.F.S. (MINIMUM) ON APPROVED DRAINAGE MAT ON 1/2" (12.7) DENSGLASS GOLD GYPSUM BOARD ON STUDS CONFORMING TO O.B.C. (9.23.10.1.) & SECTION 1.1., INSULATION, APPROVED 6 MIL. POLYETHYLENE VAPOUR BARRIER, 1/2" (12.7) GYPSUM WALLBOARD INT. FINISH. (REFER TO 35 NOTE AS REQUIRED)

41A STUCCO WALL CONSTRUCTION W/ CONTIN. INSULATION STUCCO FINISH CONFORMING TO O.B.C. SECTION 9.28. AND APPLIED PER MANUFACTURERS SPECIFICATIONS OVER 1 1/2" (38) E.I.F.S. (MINIMUM) ON APPROVED DRAINAGE MAT ON APPROVED AIR/WATER BARRIER AS PER O.B.C. 9.27.3. ON EXTERIOR TYPE RIGID INSULATION (JOINTS UNTAPED) MECHANICALLY FASTENED AS PER MANUFACTURERS SPECIFICATIONS, ON 7/16" EXTERIOR TYPE SHEATHING ON STUDS CONFORMING TO O.B.C. (9.23.10.1.) & SECTION 1.1., INSULATION, APPROVED 6 MIL. POLYETHYLENE VAPOUR BARRIER, 1/2" (12.7) GYPSUM WALLBOARD INT. FINISH. (REFER TO 35 NOTE AS REQUIRED)

41B STUCCO WALL @ GARAGE CONST. STUCCO FINISH CONFORMING TO O.B.C. SECTION 9.28. AND APPLIED PER MANUFACTURERS SPECIFICATIONS OVER 1 1/2" (38) E.I.F.S. (MINIMUM) ON APPROVED DRAINAGE MAT ON 1/2" (12.7) DENSGLASS GOLD GYPSUM BRD. ON STUDS CONFORMING TO O.B.C. (9.23.10.1.) & SECTION 1.1., 1/2" (12.7) GYPSUM WALLBOARD INT. FINISH. (REFER TO 35 NOTE AS REQ.) \*\*\* FOR DWELLINGS USING CONTIN. INSULATION CONSTRUCTION, PROVIDE APPROVED DRAINAGE MAT ON 7/16" (11) EXTERIOR TYPE SHEATHING OVER FURRING (AS REQ.) AND STUDS IN LIEU OF 1 1/2" (38) E.I.F.S. (MINIMUM) ON APPROVED DRAINAGE MAT ON 1/2" (12.7) DENSGLASS GOLD GYPSUM BRD.

42 UNSUPPORTED FOUNDATION WALLS (9.15.4.2.) REINFORCING AT STAIRS AND SUNKEN FLOOR AREAS 2-20M BARS IN TOP PORTION OF WALL (UP TO 8'-0" OPENING) 3-20M BARS IN TOP PORTION OF WALL (8'-0" TO 10'-0" OPENING) 4-20M BARS IN TOP PORTION OF WALL (10'-0" TO 15'-0" OPENING) - BARS STACKED VERTICALLY AT INTERIOR FACE OF WALL @ 6" O.C. REINFORCING AT BASEMENT WINDOWS 2-15M HORIZ. REINFORCING ON THE INSIDE AND OUTSIDE FACE OF THE FOUNDATION WALL BELOW THE WIN. SILL. EXTEND BARS 24" (610) BEYOND THE OPENING. 2-15M VERTICAL REINFORCING ON THE INSIDE AND OUTSIDE FACE OF THE FOUNDATION WALL ON EACH SIDE OF THE WINDOW OPENING. - BARS TO HAVE MIN. 2" (50) CONC. COVER - BARS TO EXTEND 2'-0" (610) BEYOND BOTH SIDES OF OPENING

43 STUD WALL REINFORCEMENT PROVIDE STUD WALL REINFORCEMENT IN MAIN BATHROOM CONFORMING TO O.B.C. (9.5.2.3.(1) AND 3.8.3.8.(3)) (REFER TO DETAILS)

44 WINDOW WELLS WHERE A WINDOW OPENS INTO A WINDOW WELL, A CLEARANCE OF NOT LESS THAN 21 5/8" (550) SHALL BE PROVIDED IN FRONT OF THE WINDOW. EVERY WINDOW WELL SHALL BE DRAINED TO THE FOOTING LEVEL OR OTHER SUITABLE LOCATION WITH A 4" (100) WEEPING TILE C/W A FILTER CLOTH WRAP AND FILLED WITH CRUSHED STONE. (9.9.10.1.(5), 9.14.6.3.)

45 SLOPED CEILING CONSTRUCTION ((SB-12) 2.1.1.7., 9.23.4.2.) 2"x12" (38x286) ROOF JOISTS @ 16" (406) O.C. MAX. (UNLESS OTHERWISE NOTED) W/ 2"x2" (38x38) PURLINS @ 16" (406) O.C. PERPENDICULAR TO ROOF JOIST (PURLINS NOT REQ. W/ SPRAY FOAM), W/ INSULATION BETWEEN JOIST, 6 mil POLYETHYLENE VAPOUR BARRIER, 1/2" (12.7) GYPSUM WALLBOARD INT. FINISH OR APPROVED EQ. INSULATION VALUE DIRECTLY ABOVE THE INNER SURFACE OF EXTERIOR WALLS SHALL NOT BE LESS THAN R20 (3.52 RSI).

46 FLAT ROOF/BALCONY CONSTRUCTION WATERPROOFING MEMBRANE (9.26.11, 9.26.15, 9.26.16) FULLY ADHERED TO 5/8" (15.9) T&G EXTERIOR GRADE PLYWOOD SHEATHING ON 2"x2" (38x38) PURLINS ANGLED TOWARDS SCUPPER @ 2% MINIMUM LAID PERPENDICULAR TO 2"x8" (38x184) FLOOR JOISTS @ 16" (406) O.C. (UNLESS OTHERWISE NOTED). BUILT UP CURB TO BE 4" (100) MIN. ABOVE FINISHED BALCONY FLOOR, CONTINUOUS 'L' TRIM DRIP EDGE TO BE PROVIDED ON OUTSIDE FACE OF CURB. SCUPPER DRAIN TO BE LOCATED 24" (610) MIN. AWAY FROM HOUSE. PREFINISHED ALUMINUM OR PANEL FOR UNDERSIDE OF SOFFIT (9.23.2.3). REMOVE CURB WHERE REQ. BALCONY CONDITION SEE FLAT ROOF/BALCONY CONSTRUCTION NOTE. INCLUDE 2"x4" (38x89) PT. DECKING W/ 1/4" (6.4) GAPS LAID FLAT PARALLEL TO JOISTS ON 2"x4" (38x89) PT. SLEEPERS @ 12" (305) O.C. LAID FLAT PERPENDICULAR TO JOISTS BALCONY OVER HEATED SPACE CONDITION SEE FLAT ROOF/BALCONY CONSTRUCTION NOTE FOR ASSEMBLY. REFER TO PLANS FOR FLOOR JOIST SIZE & REFER TO HEX NOTE 9 FOR INSULATION AND INTERIOR FINISH

47 BARREL VAULT CONSTRUCTION CANTILEVERED 2"x4" (38x89) SPACERS LAID FLAT ON 2"x10" (38x235) SPR. #2 ROOF JOIST NAILED TO BUILT-UP 3-3/4" (19) PLYWOOD HEADER PROFILED FOR BARREL. SPRAY FOAM INSULATION BETWEEN JOISTS W/ GYPSUM BOARD. INTERIOR FIN. (REFER TO DETAILS)

REFER TO SB-12 ENERGY EFFICIENCY DESIGN MATRIX ON THE TITLE PAGE FOR ALL VALUES AS REQUIRED PER 3.1.1., 3.1.2., 3.1.3. OF THE OBC.

SECTION 1.1. WALL STUDS

- REFER TO THIS CHART FOR STUD SIZE & SPACING AS REQUIRED FOR EXTERIOR WALLS ONLY. REFER TO SITING & GRADING PLAN OF THIS UNIT FOR CONFIRMATION OF TOP OF FOUNDATION WALL AND ADDITIONAL INFORMATION.

- IF STUD WALL HEIGHT EXCEEDS MAX. UNSUPPORTED HEIGHT, WALL NEEDS TO BE REVIEWED AND APPROVED BY ENGINEER.

Table with columns: MIN. STUD SIZE, in (mm), SUPPORTED LOADS (EXTERIOR), MAX. STUD SPACING, in (mm) O.C., MAX. UNSUPPORTED HGT., ft-in (m)

SECTION 2.0. GENERAL NOTES

2.1. WINDOWS

- 1) EXCEPT WHERE A DOOR ON THE SAME FLOOR LEVEL AS THE BEDROOM PROVIDES DIRECT ACCESS TO THE EXTERIOR, EVERY FLOOR LEVEL CONTAINING A BEDROOM IS TO HAVE AT LEAST ONE OUTSIDE WINDOW W/ MIN. 0.35m2 UNOBSTRUCTED OPEN PORTION W/ NO DIMENSION LESS THAN 1'-3" (380), CAPABLE OF MAINTAINING THE OPENING WITH THE NEED FOR ADDITIONAL SUPPORT, CONFORMING TO 9.9.10. 2) WINDOW GUARDS: A GUARD OR A WINDOW WITH A MAXIMUM RESTRICTED OPENING WIDTH OF 4" (100) IS REQUIRED WHERE THE TOP OF THE WINDOW SILL IS LOCATED LESS THAN 1'-7" (480) ABOVE FIN. FLOOR AND THE DISTANCE FROM THE FINISHED FLOOR TO THE ADJACENT GRADE IS GREATER THAN 5'-11" (1800), (9.8.8.1.) 3) WINDOWS IN EXIT STAIRWAYS THAT EXTEND TO LESS THAN 2'-11" (900) [3'-6" (1070) FOR ALL OTHER BUILDINGS] SHALL BE PROTECTED BY GUARDS IN ACCORDANCE WITH NOTE #2 (ABOVE), OR THE WINDOW SHALL BE NON-OPERABLE AND DESIGNED TO WITHSTAND THE SPECIFIED LOADS FOR BALCONY GUARDS AS PROVIDED IN 4.1.5.15 OR 9.8.8.2

4) REFER TO TITLE PAGE FOR MAX. U-VALUE REQUIREMENTS

2.2. CEILING HEIGHTS

THE CEILING HEIGHTS OF ROOMS AND SPACES SHALL CONFORM TO TABLE 9.5.3.1.

Table with columns: ROOM OR SPACE, MINIMUM HEIGHTS

2.3. MECHANICAL / PLUMBING

1) MECHANICAL VENTILATION IS REQUIRED TO PROVIDE 0.7 AIR CHANGE PER HOUR IF NOT AIR CONDITIONED 1 PER HOUR IF AIR CONDITIONED AVERAGED OVER 24 HOURS, WHEN A VENTILATION FAN (PRINCIPAL EXHAUST) IS REQUIRED, CONFORM TO OBC 9.32.3.4. WHEN A HRV IS REQUIRED, CONFORM TO 9.32.3.11. REFER TO MECHANICAL DRAWINGS.

2) REFER TO HOT WATER TANK MANUFACTURER SPECS. CONFORM TO OBC 9.31.6.

3) REFER TO TITLE PAGE FOR SPACE HEATING EQUIPMENT, HRV AND DOMESTIC HOT WATER HEATER MINIMUM EFFICIENCIES.

4) DRAIN WATER HEAT RECOVERY UNIT(S) WILL BE INSTALLED CONFORMING TO THE REQUIREMENTS OF 3.1.1.12. OF THE O.B.C.

2.4. LUMBER

- 1) ALL LUMBER SHALL BE SPRUCE No.2 GRADE OR BETTER, UNLESS NOTED OTHERWISE. 2) STUDS SHALL BE STUD GRADE SPRUCE, UNLESS NOTED OTHERWISE. 3) LUMBER EXPOSED TO THE EXTERIOR TO BE SPRUCE No. 2 GRADE PRESSURE TREATED OR CEDAR, UNLESS NOTED OTHERWISE. 4) ALL LAMINATED VENEER LUMBER (LVL) BEAMS, GIRDER TRUSSES, AND METAL HANGER CONNECTIONS SUPPORTING ROOF FRAMING TO BE DESIGNED & CERTIFIED BY FLOOR AND ROOF TRUSS MANUFACTURER. 5) JOIST HANGERS: PROVIDE APPROVED METAL HANGERS FOR ALL JOISTS AND BUILT-UP WOOD MEMBERS INTERSECTING WITH FLUSH BUILT-UP WOOD MEMBERS. 6) WOOD FRAMING NOT TREATED WITH A WOOD PRESERVATIVE. IN CONTACT WITH CONCRETE, SHALL BE SEPARATED FROM THE CONC. BY AT LEAST 2 mil POLYETHYLENE FILM. No.50 (45lbs) ROLL ROOFING OR OTHER DAMPROOFING MATERIAL, EXCEPT WHERE THE WOOD MEMBER IS AT LEAST 6" (152) ABOVE THE GROUND.

2.5. STEEL

- 1) STRUCTURAL STEEL SHALL CONFORM TO CAN/CSA-G40-21 GRADE 300W. HOLLOW STRUCT. SECTIONS SHALL CONFORM TO CAN/CSA-G40-21 GRADE 350W CLASS "H". 2) REINFORCING STEEL SHALL CONFORM TO CSA-G30-18M GRADE 400R.

2.6. FLAT ARCHES

- 1) FOR 8'-0" (2440) CEILINGS, FLAT ARCHES SHALL BE 6'-10" (2080) A.F.F. 2) FOR 9'-0" (2740) CEILINGS, FLAT ARCHES SHALL BE 7'-10" (2400) A.F.F. 3) FOR 10'-0" (3040) CEILINGS, FLAT ARCHES SHALL BE 8'-6" (2600) A.F.F.

2.7. ROOF OVERHANGS

1) ALL ROOF OVERHANGS SHALL BE 1'-0" (305), UNLESS NOTED OTHERWISE.

2.8. FLASHING (9.20.13., 9.26.4. & 9.27.3.)

1) FLASHING MATERIALS & INSTALLATION SHALL CONFORM TO O.B.C.

2.9. GRADING

1) THE BUILDING SHALL BE LOCATED OR THE BUILDING SITE GRADED SO THE WATER WILL NOT ACCUMULATE AT OR NEAR THE BUILDING AND WILL NOT ADVERSELY AFFECT ADJACENT PROPERTIES. CONFORM TO 9.14.6.

2.10. ULC SPECIFIED ASSEMBLIES

ALL REQUIRED INDIVIDUAL COMPONENTS THAT FORM PART OF ANY 'ULC LISTED ASSEMBLY', SPECIFIED WITHIN THESE DRAWINGS, CANNOT BE ALTERED OR SUBSTITUTED FOR ANY OTHER MATERIAL/PRODUCT OR SPECIFIED MANUFACTURER THAT IS IDENTIFIED IN THAT 'SPECIFIED ULC LISTING'. THERE SHALL BE NO DEVIATIONS UNDER ANY CIRCUMSTANCES IN ANY 'ULC LISTED ASSEMBLY' IDENTIFIED IN THESE DRAWINGS.

SECTION 3.0. LEGEND

3.1. WOOD LINTELS AND BUILT-UP WOOD (DIVISION B PART 9, TABLES A8 TO A10 AND A12, A15 & A16)

Table with columns: FORMING PART OF SENTENCE, 2"x8" SPRUCE #2, 2"x10" SPRUCE #2, 2"x12" SPRUCE #2

3.2. STEEL LINTELS SUPPORTING MASONRY VENEER (DIVISION B PART 9, TABLE 9.20.5.2.B.)

Table with columns: CODE, SIZE, BRICK, STONE

3.3. DOOR SCHEDULE

Table with columns: 1, 1A, 1B, 1C, 1D, 1E, 2A, 2, 3, 3A, 4, 4A, 5

3.4. ACRONYMS

Table with columns: AFF, ABOVE FINISHED FLOOR, JST, JOIST, BBFM, BEAM BY FLOOR MANUFACTURER, LIN, LINEN CLOSET, BG, FIXED GLASS W/ BLACK BACKING, LVL, LAMINATED VENEER LUMBER, BM, BEAM, OTB/A, OPEN TO BELOW/ABOVE, BBRM, BEAM BY ROOF MANUFACTURER, PL, POINT LOAD, CRF, CONVENTIONAL ROOF FRAMING, PLT, PLATE, C/W, COMPLETE WITH, PT, PRESSURE TREATED, DJ/TJ, DOUBLE JOIST/ TRIPLE JOIST, PTD, PAINTED, DO, DO OVER, PWD, POWDER ROOM, DRP, DROPPED, RT, ROOF TRUSS, E.I.F.S., EXTERIOR INSULATION FINISH SYSTEM, RWL, RAIN WATER LEADER, ENG, ENGINEERED, SB, SOLID BEARING WOOD POST, EST, ESTIMATED, SBFA, SB FROM ABOVE, FA, FLAT ARCH, SJ, SINGLE JOIST, FD, FLOOR DRAIN, SPR, SPRUCE, FG, FIXED GLASS, STL, STEEL, FL, FLUSH, T/O, TOP OF, FLR, FLOOR, TYP, TYPICAL, GT, GIRDER TRUSS, U/S, UNDERSIDE, HB, HOSE BIB, WD, WOOD, HRV, HEAT RETURN VENTILATION UNIT, WIC, WALK IN CLOSET, HWT, HOT WATER TANK, WP, WEATHER PROOF

3.5. SYMBOLS

ALL ELECTRICAL FACILITIES SHALL BE INSTALLED IN ACCORDANCE WITH SECTION 9.34.

Table with columns: CLASS 'B' VENT, EXHAUST VENT, DUPLEX OUTLET (12" HIGH), DUPLEX OUTLET (HEIGHT AS NOTED A.F.F.), HEAVY DUTY OUTLET, SWITCH (2/3/4 WAY), ROUGH IN FOR ELECTRIC VEHICLE CHARGING STATION (9.34.4), LIGHT FIXTURE (CEILING MOUNTED), POT LIGHT, LIGHT FIXTURE (WALL MOUNTED), LIGHT FIXTURE (PULL CHAIN), TELEPHONE JACK, CABLE T.V. JACK, CHANDELIER (CEILING MOUNTED), CENTRAL VACUUM OUTLET

SA SMOKE ALARM (9.10.19.) PROVIDE ONE PER FLOOR, NEAR THE STAIRS CONNECTING THE FLOOR LEVEL. ALARMS ARE TO BE INSTALLED IN EACH SLEEPING ROOM AND IN A LOCATION BETWEEN SLEEPING ROOMS AND CONNECTING HALLWAYS AND WIRED TO BE INTERCONNECTED TO ACTIVATE ALL ALARMS IF ONE SOUNDS. ALARMS ARE TO BE CONNECTED TO AN ELECTRICAL CIRCUIT AND WITH A BATTERY BACKUP. ALARM SIGNAL SHALL MEET TEMPORAL SOUND PATTERNS MIN. ALARMS SHALL HAVE A VISUAL SIGNALLING COMPONENT AS PER THE "NATIONAL FIRE ALARM AND SIGNALING CODE 72".

CMD CARBON MONOXIDE ALARM (9.33.4.) \*\* CHECK LOCAL BY-LAWS FOR REQUIREMENTS \*\* A CARBON MONOXIDE ALARM(S) CONFORMING TO CAN/CGA-6.19 SHALL BE INSTALLED ON OR NEAR THE CEILING IN EACH DWELLING UNIT ADJACENT TO EACH SLEEPING AREA. CARBON MONOXIDE ALARM(S) SHALL BE PERMANENTLY WIRED WITH NO DISCONNECT SWITCH, WITH AN ALARM THAT IS AUDIBLE WITHIN SLEEPING ROOMS WHEN THE INTERVENING DOORS ARE CLOSED.

SB SOLID BEARING (BUILT-UP WOOD COLUMNS AND STUD POSTS) THE WIDTH OF A WOOD COLUMN SHALL NOT BE LESS THAN THE WIDTH OF SUPPORTED MEMBER. BUILT-UP WOOD COLUMNS SHALL BE NAILED TOGETHER WITH NOT LESS THAN 3" (76) NAILS SPACED NOT MORE THAN 11 3/4" (300) O.C. THE NUMBER OF STUDS IN A WALL DIRECTLY BELOW A GIRDER TRUSS OR ROOF BEAM SHALL CONFORM TO TABLES A-34 TO A-37. (9.17.4., 9.23.10.7.)

Table with columns: TWO STOREY VOLUME SPACE. SEE CONSTRUCTION NOTE 39., VARYING PLATES, BUILT-OUT FLOORS, BEARING WALLS, ICE & WATER SHIELD, EXPOSED BUILDING FACE -O.B.C. 9.10.14, OR 9.10.15. REFER TO HEX NOTE 35. & DETAILS FOR TYPE AND SPECIFICATIONS.

Table with columns: 1 HR. PARTY WALL REFER TO HEX NOTE 40., 2 HR. FIREWALL REFER TO HEX NOTE 40A.

SECTION 4.0. CLIMATIC DATA

DESIGN SNOW LOAD (9.4.2.2.): 1.01 kPa WIND LOAD (q50) (SB-1.2.): 0.44 kPa

Stamp: LICENSED PROFESSIONAL ENGINEER A. KONG 100184942 NOV. 30 / 2018 PROVINCE OF ONTARIO FOR STRUCTURAL ONLY EXCLUDING ENGINEERED ROOF TRUSS, FLOOR JOIST, BEAM DESIGNS.

CONTRACTOR MUST VERIFY ALL DIMENSIONS ON THE JOB. REPORT ANY DISCREPANCIES TO HUNT DESIGN ASSOCIATES INC. (H.D.A.I.) BEFORE PROCEEDING WITH THE WORK. ALL THE DRAWINGS & SPECIFICATIONS ARE THE INSTRUMENTS OF SERVICE AND ARE THE PROPERTY OF H.D.A.I. ALL CONSTRUCTION TO ADHERE TO THESE PLANS AND SPECIFICATIONS AND TO CONFORM TO THE ONTARIO BUILDING CODE AND ALL OTHER APPLICABLE CODES AND AUTHORITIES HAVING JURISDICTION. THESE REQUIREMENTS ARE TO BE TAKEN AS MINIMUM SPECIFICATIONS. ONT. REG. 332/12. CONSTRUCTION NOTE REVISION DATE: MARCH 21, 2018

CONSTRUCTION NOTES

THE UNDERSIGNED HAS REVIEWED AND TAKES RESPONSIBILITY FOR THIS DESIGN AND HAS THE QUALIFICATIONS AND MEETS THE REQUIREMENTS SET OUT IN THE ONTARIO BUILDING CODE TO BE A DESIGNER.

QUALIFICATION INFORMATION Oáin Fairbairn 20201 NAME REGISTRATION INFORMATION SIGNATURE BCIN HUNT DESIGN ASSOCIATES INC. 19695

HUNT DESIGN ASSOCIATES INC. www.huntdesign.ca

GOLDPARK HOMES - 217020 PINE VALLEY, VAUGHAN ONT.

UNIT 4004 - THE DALERIDGE REV. 2018/11/30

Drawn By HDAL/OF Checked By OF Scale 3/16"=1'-0" File Number 217020WS4004-LOT 94 Page Number 13 of 13 8966 Woodbine Ave, Markham, ON L3R 0J7 T 905.737.5133 F 905.737.7326

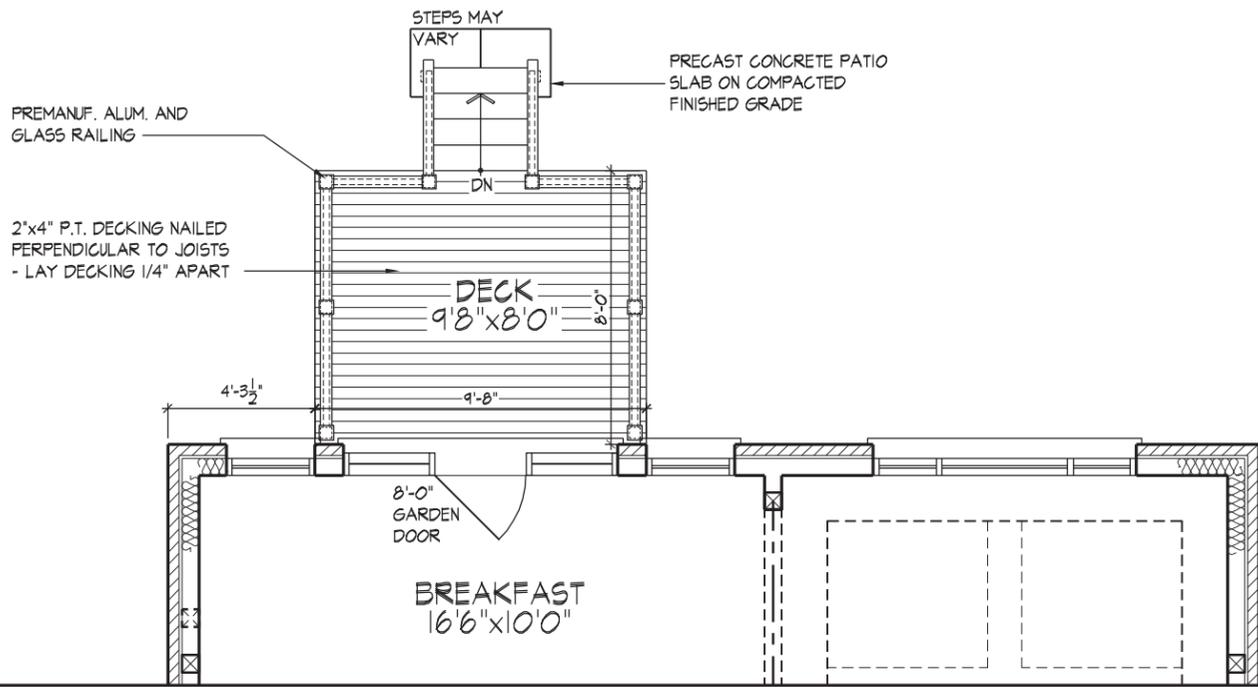

**NOTE:**  
REFER TO STANDARD FLOOR PLANS FOR COMPLETE DIMENSIONS & STRUCTURAL INFORMATION

PART. GROUND FLOOR PLAN ELEV. 'A' - W.O.D. COND.

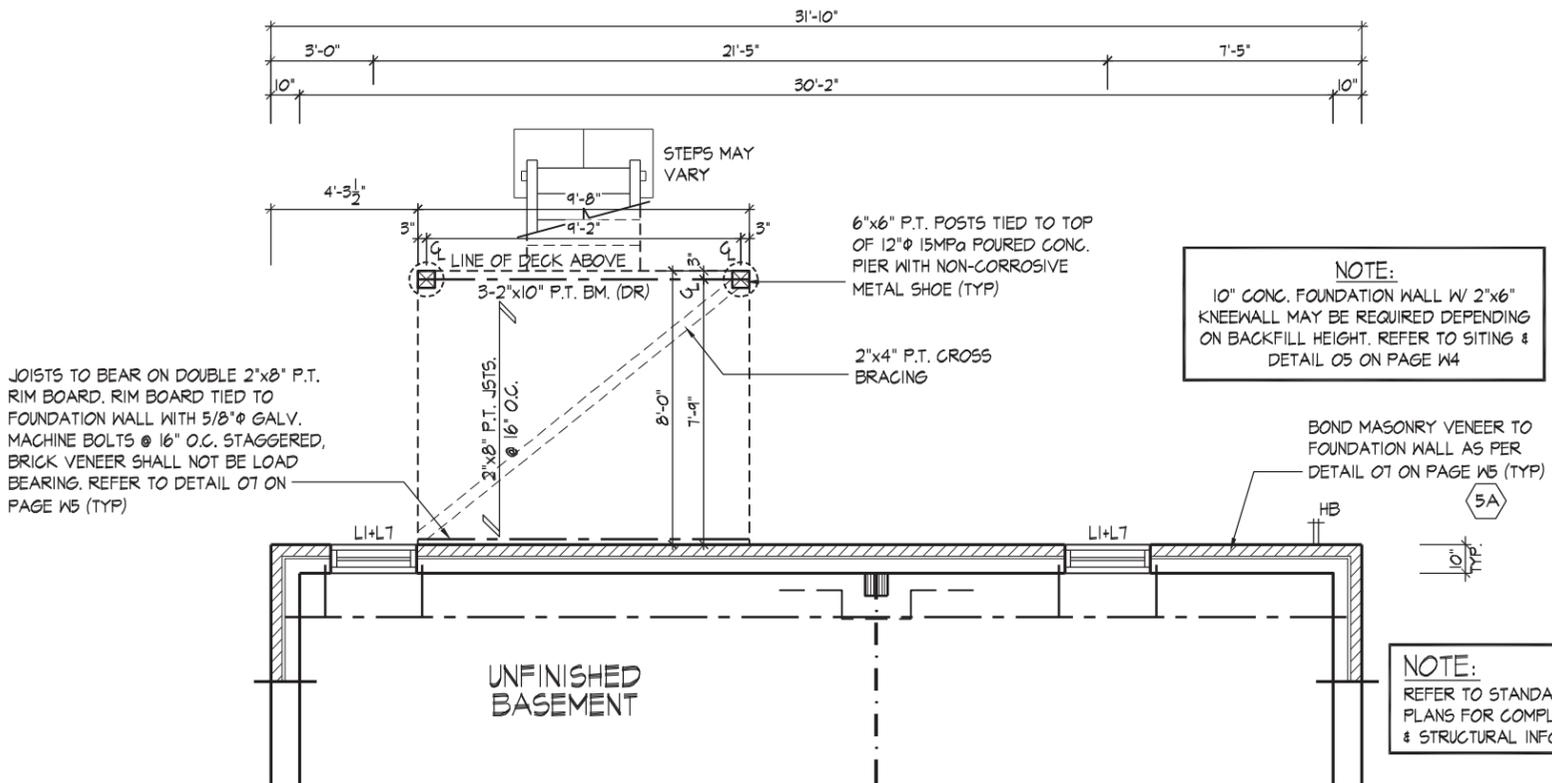

PART. BASEMENT PLAN ELEV. 'A' - W.O.D. COND.



It is the builder's complete responsibility to ensure that all plans submitted for approval fully comply with the Architectural Guidelines and all applicable regulations and requirements including zoning provisions and any provisions in the subdivision agreement. The Control Architect is not responsible in any way for examining or approving site (lotting) plans or working drawings with respect to any zoning or building code or permit matter or that any house can be properly built or located on its lot.

This is to certify that these plans comply with the applicable Architectural Design Guidelines approved by the City of VAUGHAN.

**JOHN G. WILLIAMS LTD., ARCHITECT**  
ARCHITECTURAL CONTROL REVIEW AND APPROVAL

APPROVED BY: \_\_\_\_\_

DATE: DEC 03, 2018

This stamp certifies compliance with the applicable Design Guidelines only and bears no further professional responsibility.

PART. REAR ELEV. 'A' - W.O.D. COND.

REFER TO FRONT ELEVATION & STANDARD REAR FOR TYPICAL NOTES & INFO.

**LICENSED PROFESSIONAL ENGINEER**  
A. KONG  
100184942  
NOV. 30/2018  
PROVINCE OF ONTARIO

FOR STRUCTURAL ONLY EXCLUDING ENGINEERED ROOF TRUSS, FLOOR JOIST, FLOOR LVL BEAM DESIGNS

WINDOW SIZES FOR W.O.D. CONDITIONS: WINDOWS TO BE LOCATED WITHIN JOIST SPACE. IF GRADE PERMITS, TOP OF WINDOW TO BE 7'-10" A.F.F.

**WALK OUT DECK CONDITION**

All drawings specifications related documents and design are the copyright property of Hunt Design Associates (H.D.A). Reproduction of this property in whole or in part is strictly prohibited without H.D.A.'s written permission (H.D.A. assumes no responsibility or liability for this property unless it bears the appropriate BCIN number and original signature).

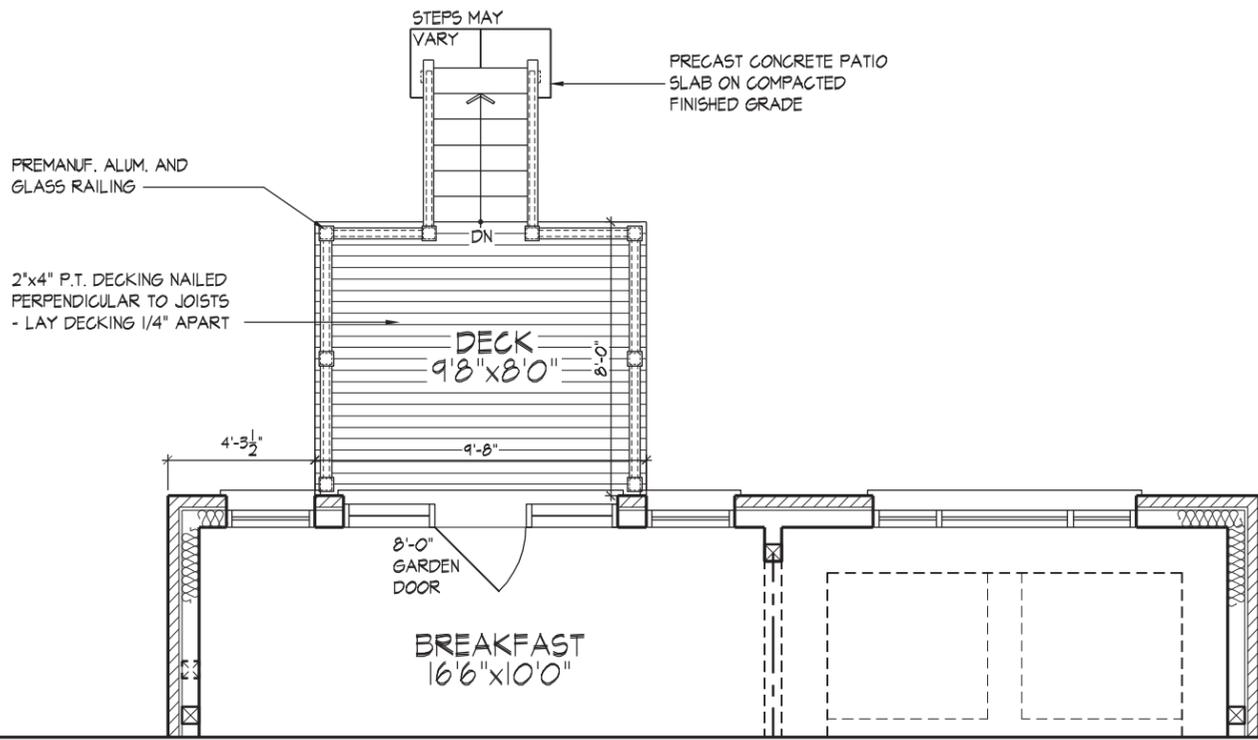

**NOTE:**  
REFER TO STANDARD FLOOR PLANS FOR COMPLETE DIMENSIONS & STRUCTURAL INFORMATION

PART. GROUND FLOOR PLAN ELEV. 'A' - L.O.D. COND.

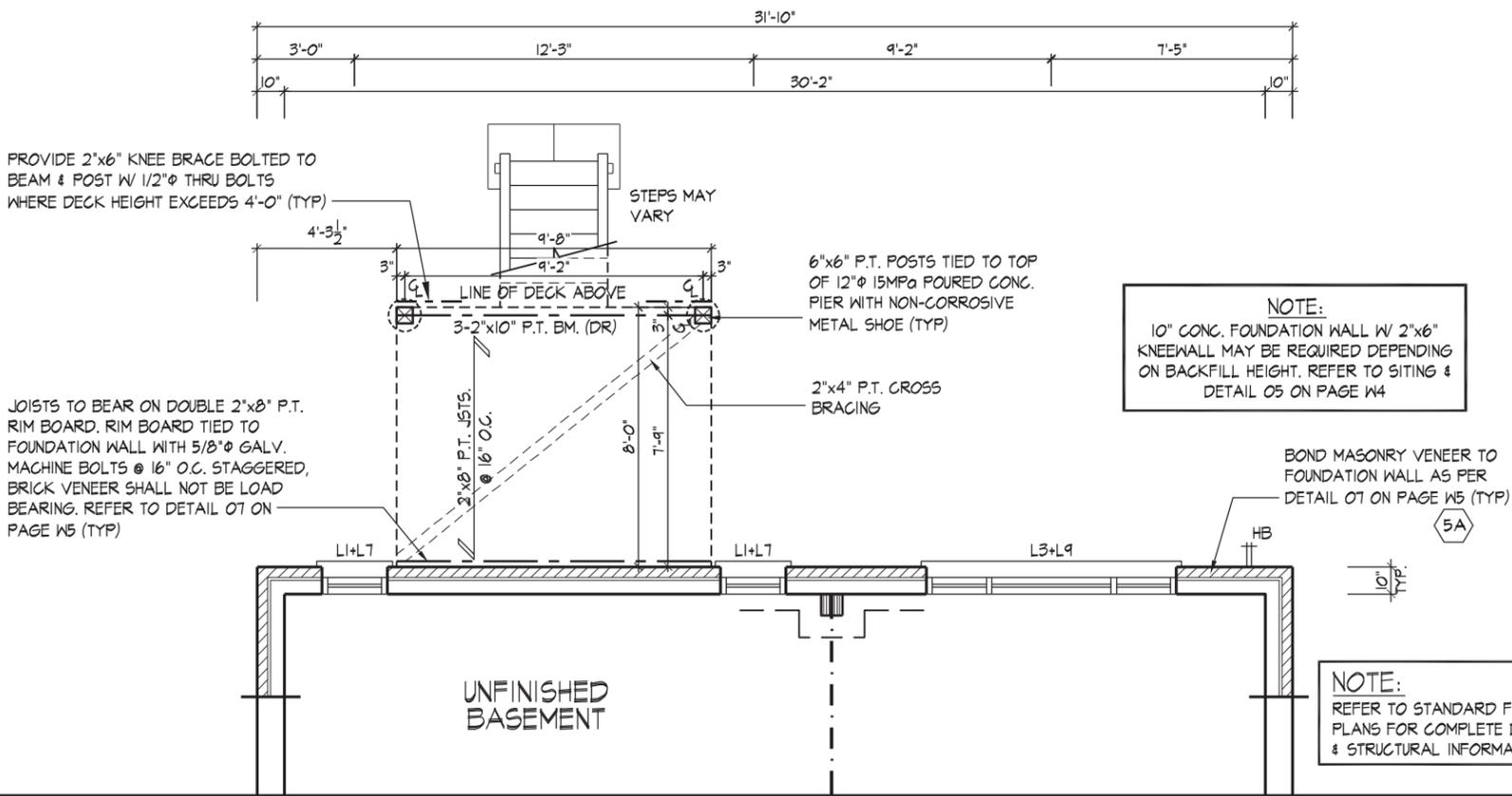

**NOTE:**  
REFER TO STANDARD FLOOR PLANS FOR COMPLETE DIMENSIONS & STRUCTURAL INFORMATION

PART. BASEMENT PLAN ELEV. 'A' - L.O.D. COND.



It is the builder's complete responsibility to ensure that all plans submitted for approval fully comply with the Architectural Guidelines and all applicable regulations and requirements including zoning provisions and any provisions in the subdivision agreement. The Control Architect is not responsible in any way for examining or approving site (lotting) plans or working drawings with respect to any zoning or building code or permit matter or that any house can be properly built or located on its lot.

This is to certify that these plans comply with the applicable Architectural Design Guidelines approved by the City of VAUGHAN.

**JOHN G. WILLIAMS LTD., ARCHITECT**  
ARCHITECTURAL CONTROL REVIEW AND APPROVAL  
APPROVED BY: \_\_\_\_\_  
DATE: DEC 03, 2018  
This stamp certifies compliance with the applicable Design Guidelines only and bears no further professional responsibility.

PART. REAR ELEV. 'A' - L.O.D. COND.

REFER TO FRONT ELEVATION & STANDARD REAR FOR TYPICAL NOTES & INFO.

**LICENSED PROFESSIONAL ENGINEER**  
A. KONG  
100184942  
NOV. 30/2018  
PROVINCE OF ONTARIO

FOR STRUCTURAL ONLY EXCLUDING ENGINEERED ROOF TRUSS, FLOOR JOIST, FLOOR LVL BEAM DESIGNS.

WINDOW SIZES FOR L.O.D. CONDITIONS: MATCH WIDTH OF WINDOW ABOVE AND WINDOWS TO BE 30" DEEP. WINDOWS TO BE LOCATED WITHIN JOIST SPACE. IF GRADE PERMITS, TOP OF WINDOW TO BE 8'-0" A.F.F.

**LOOK OUT DECK CONDITION**

All drawings specifications related documents and design are the copyright property of Hunt Design Associates (H.D.A). Reproduction of this property in whole or in part is strictly prohibited without H.D.A.'s written permission (H.D.A. assumes no responsibility or liability for this property unless it bears the appropriate BCIN number and original signature.)



SIZE & SPACING OF STUDS: (OBC REFERENCE - TABLE 9.23.10.1.)

MIN. STUD SIZE, in (mm)	SUPPORTED LOADS (EXTERIOR)			
	ROOF w/ OR w/o ATTIC	ROOF w/ OR w/o ATTIC & 1 FLOOR	ROOF w/ OR w/o ATTIC & 2 FLOOR	ROOF w/ OR w/o ATTIC & 3 FLOOR
	MAX. STUD SPACING in (mm) O.C.			
MAX. UNSUPPORTED HGT. ft-in (m)				
2"x4" (38x89)	24" (610)	16" (405)	12" (305)	N/A
2"x6" (38x140)	9'-10" (3.0)	9'-10" (3.0)	9'-10" (3.0)	N/A
	-	24" (610)	16" (406)	12" (305)
	-	9'-10" (3.0)	11'-10" (3.6)	5'-11" (1.8)

- REFER TO THIS CHART FOR STUD SIZE & SPACING AS REQUIRED FOR EXTERIOR WALLS ONLY. REFER TO SITING & GRADING PLAN OF THIS UNIT FOR CONFIRMATION OF TOP OF FOUNDATION WALL AND ADDITIONAL INFORMATION.  
 - IF STUD WALL HEIGHT EXCEEDS MAX. UNSUPPORTED HEIGHT, WALL NEEDS TO BE REVIEWED AND APPROVED BY ENGINEER.

BASE FLASHING CONFORMING TO TABLE 9.20.13.1 TO EXTEND 3/16" BEYOND OUTER FACE OF FOUNDATION WALL, TIED TO EXT. SHEATHING UNDER AIR/WATER BARRIER, PROVIDE 6" MINIMUM LAP JOINT.

WEEP HOLES @ 32" O.C. AT BASE FLASHING AND OVER ALL OPENINGS. PROVIDE P.V.C. BRICK VENTILATOR @ ALL WEEP HOLE LOCATIONS.

PROVIDE MASONRY PARGING FROM TOP OF FOUNDATION WALL TO 2" BELOW FINISHED GRADE

FOUNDATION WALLS SHALL NOT EXCEED 9'-10" (3.0m) IN UNSUPPORTED HEIGHT UNLESS OTHERWISE NOTED. (9.15.4.2.1). POURED CONC. FDN. WALL WITH BITUMINOUS DAMPPROOFING AND DRAINAGE LAYER. REFER TO CHART FOR MAXIMUM UNSUPPORTED HEIGHT AND EARTH RETENTION FROM BASEMENT SLAB TO FINISHED GRADE, ON CONTINUOUS KEYS CONG. FTG. BRACE FOUNDATION WALL PRIOR TO BACKFILLING. ALL FOOTINGS SHALL REST ON NATURAL UNDISTURBED SOIL OR COMPACTED ENGINEERED FILL.

UNREINFORCED SOLID CONCRETE FOUNDATION WALLS (9.15.4.2.)

STRENGTH THICKNESS	MAX. HEIGHT FROM FIN. SLAB TO GRADE			
	UNSUPPORTED AT TOP	SUPPORTED AT TOP		
	<2.5m	2.5m & <2.75m	2.75m & <3.0m	>3.0m
8" 15 MPa	3'-11" (1.20m)	7'-0" (2.15m)	7'-0" (2.15m)	6'-10" (2.10m)
10" 15 MPa	4'-7" (1.40m)	7'-6" (2.30m)	8'-6" (2.60m)	8'-2" (2.50m)
12" 15 MPa	4'-11" (1.50m)	7'-6" (2.30m)	8'-6" (2.60m)	9'-3" (2.85m)
8" 20 MPa	3'-11" (1.20m)	7'-6" (2.30m)	7'-6" (2.30m)	7'-2" (2.20m)
10" 20 MPa	4'-7" (1.40m)	7'-6" (2.30m)	8'-6" (2.60m)	9'-3" (2.85m)
12" 20 MPa	4'-11" (1.50m)	7'-6" (2.30m)	8'-6" (2.60m)	9'-3" (2.85m)

MINIMUM STRIP FOOTING SIZES (9.15.3.)

NUMBER FLOORS SUPPORTED	SUPPORTING INT. LOAD BEARING MASONRY WALL	SUPPORTING EXTERIOR	SUPPORTING PARTY WALL
1	16" W x 6" D	16" W x 6" D	16" W x 6" D
2	24" W x 8" D	20" W x 6" D	24" W x 8" D
3	36" W x 14" D	26" W x 9" D	36" W x 14" D

NOTE: FOOTING SIZE SUBJECT TO CERTIFICATION BY A SOIL CONSULTANT

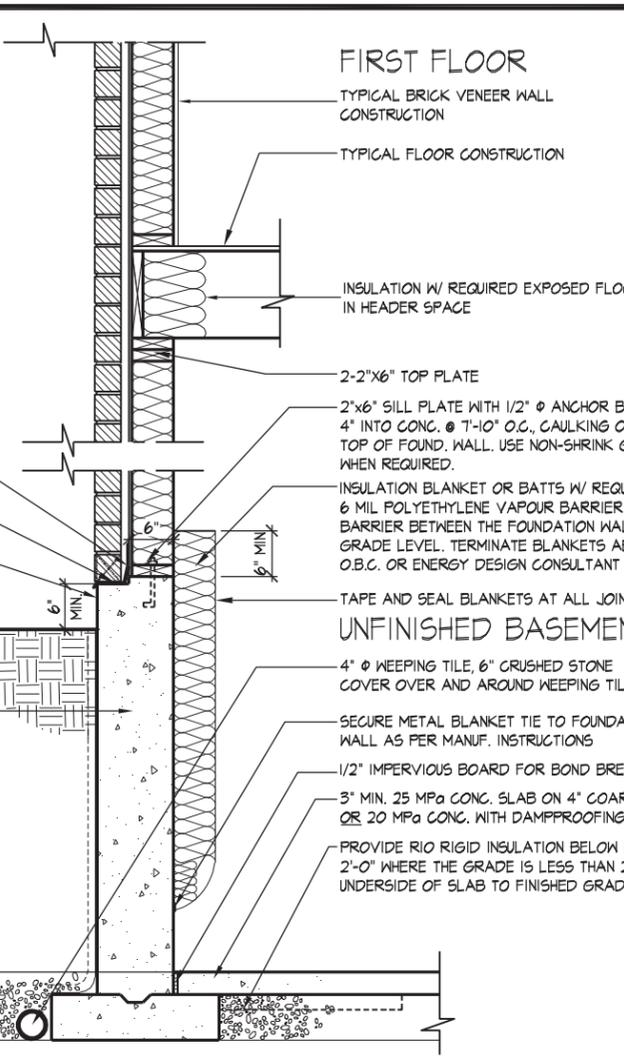

NOTE: POURED CONC. FOOTING ON NATURAL UNDISTURBED SOIL OF 125kPa (SL5) OR COMPACTED ENGINEERED FILL WITH MIN. BEARING CAPACITY OF 125kPa (SL5). FOOTING SIZE SHOWN FOR 16'-0" (4.9m) MAXIMUM JOIST SPAN ONLY. JOIST SPAN EXCEEDING 16'-0" (4.9m) SHALL BE ENGINEERED. IF SOIL BEARING DOES NOT MEET MINIMUM CAPACITY, ENGINEERED FOOTINGS ARE REQUIRED. ACTUAL SOIL BEARING CAPACITY TO BE VERIFIED WITH SOIL ENGINEERING REPORT.

NOTE: WHERE REDUCED GRADE CONDITION REQUIRES THE USE OF A FULL HEIGHT BONDED WALL, REBAR SHALL BE PROVIDED AS PER DETAIL 07 ON PG. W5

REFER TO SB-12 ENERGY EFFICIENCY DESIGN MATRIX ON THE TITLE PAGE FOR ALL VALUES AS REQUIRED PER 3.1.1., 3.1.2, 3.1.3. OF THE OBC.

05 MASONRY VENEER, 2"x6" STUDS, 10" FOUNDATION WALL Laterally UNSUPPORTED  
 1/2" = 1'-0"

SIZE & SPACING OF STUDS: (OBC REFERENCE - TABLE 9.23.10.1.)

MIN. STUD SIZE, in (mm)	SUPPORTED LOADS (EXTERIOR)			
	ROOF w/ OR w/o ATTIC	ROOF w/ OR w/o ATTIC & 1 FLOOR	ROOF w/ OR w/o ATTIC & 2 FLOOR	ROOF w/ OR w/o ATTIC & 3 FLOOR
	MAX. STUD SPACING in (mm) O.C.			
MAX. UNSUPPORTED HGT. ft-in (m)				
2"x4" (38x89)	24" (610)	16" (405)	12" (305)	N/A
2"x6" (38x140)	9'-10" (3.0)	9'-10" (3.0)	9'-10" (3.0)	N/A
	-	24" (610)	16" (406)	12" (305)
	-	9'-10" (3.0)	11'-10" (3.6)	5'-11" (1.8)

- REFER TO THIS CHART FOR STUD SIZE & SPACING AS REQUIRED FOR EXTERIOR WALLS ONLY. REFER TO SITING & GRADING PLAN OF THIS UNIT FOR CONFIRMATION OF TOP OF FOUNDATION WALL AND ADDITIONAL INFORMATION.  
 - IF STUD WALL HEIGHT EXCEEDS MAX. UNSUPPORTED HEIGHT, WALL NEEDS TO BE REVIEWED AND APPROVED BY ENGINEER.

BASE FLASHING CONFORMING TO TABLE 9.20.13.1 TO EXTEND 3/16" BEYOND OUTER FACE OF FOUNDATION WALL, TIED TO EXT. SHEATHING UNDER AIR/WATER BARRIER, PROVIDE 6" MINIMUM LAP JOINT.

WEEP HOLES @ 32" O.C. AT BASE FLASHING AND OVER ALL OPENINGS. PROVIDE P.V.C. BRICK VENTILATOR @ ALL WEEP HOLE LOCATIONS.

PROVIDE MASONRY PARGING FROM TOP OF FOUNDATION WALL TO 2" BELOW FINISHED GRADE

OPTIONAL WEEPING TILE AT REAR WALL-SEE MUNICIPAL STANDARDS

FOUNDATION WALLS SHALL NOT EXCEED 9'-10" (3.0m) IN UNSUPPORTED HEIGHT UNLESS OTHERWISE NOTED. (9.15.4.2.1). POURED CONC. FDN. WALL WITH BITUMINOUS DAMPPROOFING AND DRAINAGE LAYER. REFER TO CHART FOR MAXIMUM UNSUPPORTED HEIGHT AND EARTH RETENTION FROM BASEMENT SLAB TO FINISHED GRADE, ON CONTINUOUS KEYS CONG. FTG. BRACE FOUNDATION WALL PRIOR TO BACKFILLING. ALL FOOTINGS SHALL REST ON NATURAL UNDISTURBED SOIL OR COMPACTED ENGINEERED FILL.

UNREINFORCED SOLID CONCRETE FOUNDATION WALLS (9.15.4.2.)

STRENGTH THICKNESS	MAX. HEIGHT FROM FIN. SLAB TO GRADE			
	UNSUPPORTED AT TOP	SUPPORTED AT TOP		
	<2.5m	2.5m & <2.75m	2.75m & <3.0m	>3.0m
8" 15 MPa	3'-11" (1.20m)	7'-0" (2.15m)	7'-0" (2.15m)	6'-10" (2.10m)
10" 15 MPa	4'-7" (1.40m)	7'-6" (2.30m)	8'-6" (2.60m)	8'-2" (2.50m)
12" 15 MPa	4'-11" (1.50m)	7'-6" (2.30m)	8'-6" (2.60m)	9'-3" (2.85m)
8" 20 MPa	3'-11" (1.20m)	7'-6" (2.30m)	7'-6" (2.30m)	7'-2" (2.20m)
10" 20 MPa	4'-7" (1.40m)	7'-6" (2.30m)	8'-6" (2.60m)	9'-3" (2.85m)
12" 20 MPa	4'-11" (1.50m)	7'-6" (2.30m)	8'-6" (2.60m)	9'-3" (2.85m)

MINIMUM STRIP FOOTING SIZES (9.15.3.)

NUMBER FLOORS SUPPORTED	SUPPORTING INT. LOAD BEARING MASONRY WALL	SUPPORTING EXTERIOR	SUPPORTING PARTY WALL
1	16" W x 6" D	16" W x 6" D	16" W x 6" D
2	24" W x 8" D	20" W x 6" D	24" W x 8" D
3	36" W x 14" D	26" W x 9" D	36" W x 14" D

NOTE: FOOTING SIZE SUBJECT TO CERTIFICATION BY A SOIL CONSULTANT

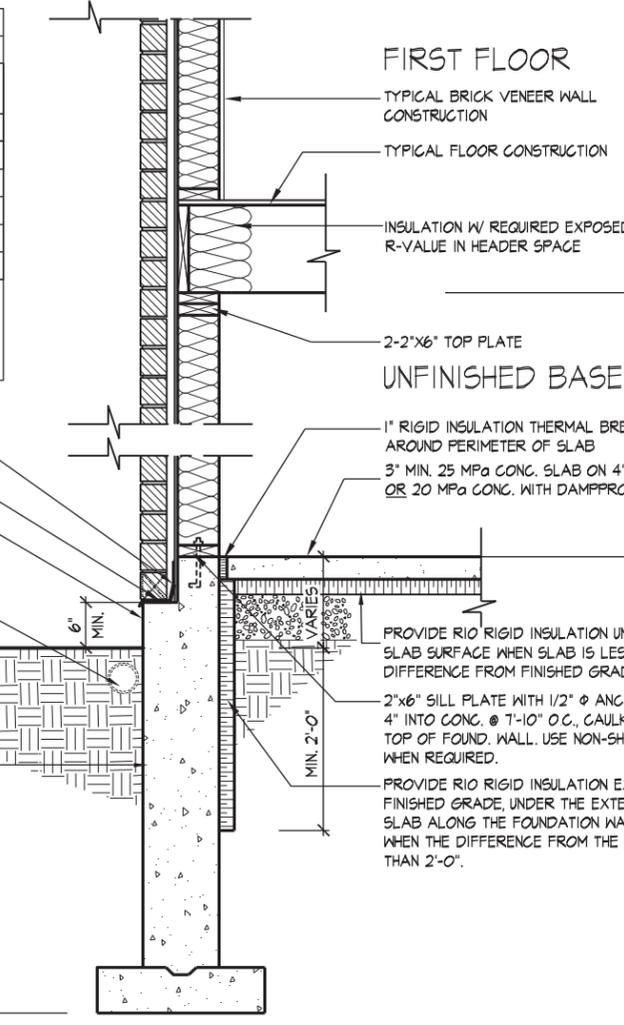

NOTE: POURED CONC. FOOTING ON NATURAL UNDISTURBED SOIL OF 125kPa (SL5) OR COMPACTED ENGINEERED FILL WITH MIN. BEARING CAPACITY OF 125kPa (SL5). FOOTING SIZE SHOWN FOR 16'-0" (4.9m) MAXIMUM JOIST SPAN ONLY. JOIST SPAN EXCEEDING 16'-0" (4.9m) SHALL BE ENGINEERED. IF SOIL BEARING DOES NOT MEET MINIMUM CAPACITY, ENGINEERED FOOTINGS ARE REQUIRED. ACTUAL SOIL BEARING CAPACITY TO BE VERIFIED WITH SOIL ENGINEERING REPORT.

NOTE: WHERE REDUCED GRADE CONDITION REQUIRES THE USE OF A FULL HEIGHT BONDED WALL, REBAR SHALL BE PROVIDED AS PER DETAIL 07 ON PG. W5

REFER TO SB-12 ENERGY EFFICIENCY DESIGN MATRIX ON THE TITLE PAGE FOR ALL VALUES AS REQUIRED PER 3.1.1., 3.1.2, 3.1.3. OF THE OBC.

06 MASONRY VENEER, 2"x6" STUDS, SLAB ON GRADE / WALK OUT BASEMENT CONDITION  
 1/2" = 1'-0"

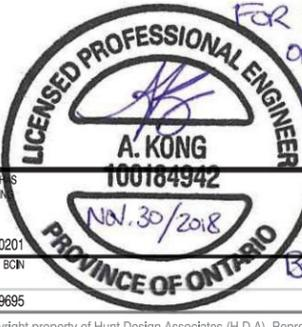

HUNT DESIGN ASSOCIATES INC.  
 www.huntdesign.ca

All drawings specifications related documents and design are the copyright property of Hunt Design Associates (H.D.A). Reproduction of this property in whole or in part is strictly prohibited without H.D.A.'s written permission (H.D.A. assumes no responsibility or liability for this property unless it bears the appropriate BCIN number and original signature).

2"x4" P.T. TOP RAIL  
 2"x4" P.T. RAIL  
 2"x2" P.T. PICKETS @ 4" O.C. MAX.  
 4"x4" P.T. MAIN CORNER POSTS  
 4"x4" P.T. INTERMEDIATE POSTS AT  
 5'-1" O.C. MAXIMUM

NOTE: ALL METAL FASTENERS SHALL BE NON-CORROSIVE.

2"x4" P.T. BOTTOM RAIL  
 2"x4" P.T. DECKING LAID PERPENDICULAR TO JOISTS 1/4" APART  
 2"x8" P.T. RIM BOARD

2"x8" P.T. BLOCKING AT POSTS CONNECTION  
 2"x8" P.T. JOISTS @ 16" O.C.  
 P.T. BEAM AS PER PLANS TIED TO TOP OF 6"x6" P.T. POSTS TIED TO TOP OF 12"Ø 15MPØ Poured CONG. PIER WITH NON-CORROSIVE METAL SHOE

POSTS TIED TO METAL SHOE ANCHOR WITH 4-3/8"Ø MACHINE BOLTS  
 1/2"Ø NON-CORROSIVE ANCHOR 4" MINIMUM INTO CONCRETE

TYPICAL FOUNDATION WALL CONSTRUCTION

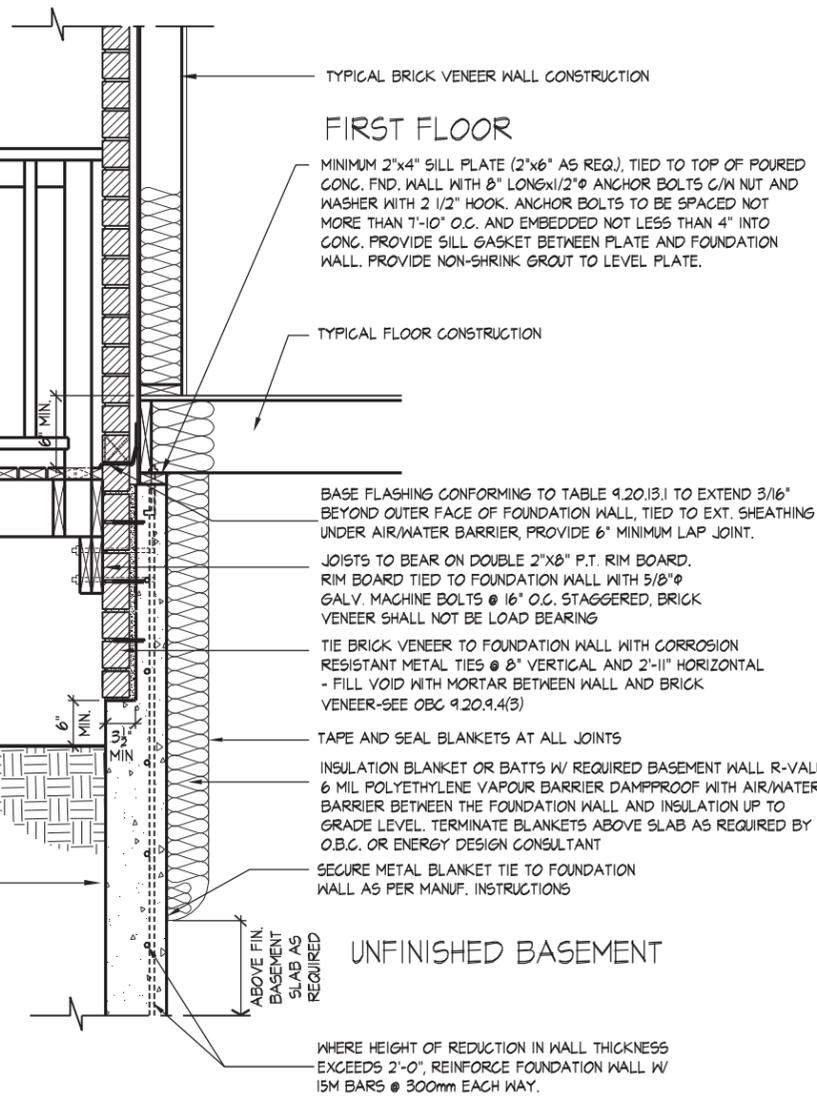

FIRST FLOOR

TYPICAL FLOOR CONSTRUCTION

BASE FLASHING CONFORMING TO TABLE 9.20.13.1 TO EXTEND 3/16" BEYOND OUTER FACE OF FOUNDATION WALL, TIED TO EXT. SHEATHING UNDER AIR/WATER BARRIER, PROVIDE 6" MINIMUM LAP JOINT.

JOISTS TO BEAR ON DOUBLE 2"x8" P.T. RIM BOARD. RIM BOARD TIED TO FOUNDATION WALL WITH 5/8"Ø GALV. MACHINE BOLTS @ 16" O.C. STAGGERED, BRICK VENEER SHALL NOT BE LOAD BEARING

TIE BRICK VENEER TO FOUNDATION WALL WITH CORROSION RESISTANT METAL TIES @ 8" VERTICAL AND 2'-11" HORIZONTAL - FILL VOID WITH MORTAR BETWEEN WALL AND BRICK VENEER-SEE OBC 9.20.9.4(3)

TAPE AND SEAL BLANKETS AT ALL JOINTS  
 INSULATION BLANKET OR BATTS W/ REQUIRED BASEMENT WALL R-VALUE, 6 MIL POLYETHYLENE VAPOUR BARRIER DAMPPROOF WITH AIR/WATER BARRIER BETWEEN THE FOUNDATION WALL AND INSULATION UP TO GRADE LEVEL. TERMINATE BLANKETS ABOVE SLAB AS REQUIRED BY O.B.C. OR ENERGY DESIGN CONSULTANT

SECURE METAL BLANKET TIE TO FOUNDATION WALL AS PER MANUF. INSTRUCTIONS

UNFINISHED BASEMENT

WHERE HEIGHT OF REDUCTION IN WALL THICKNESS EXCEEDS 2'-0", REINFORCE FOUNDATION WALL W/ 15M BARS @ 300mm EACH WAY.

07 MASONRY VENEER, TYPICAL WALK/LOOK OUT WOOD DECK, SOLID MASONRY

1/2" = 1'-0"

JOISTS TO BEAR ON DOUBLE 2"x8" P.T. RIM BOARD. RIM BOARD TIED TO FOUNDATION WALL WITH 5/8"Ø GALV. MACHINE BOLTS @ 16" O.C. STAGGERED, BRICK VENEER SHALL NOT BE LOAD BEARING

NOTE: ALL METAL FASTENERS SHALL BE NON-CORROSIVE.

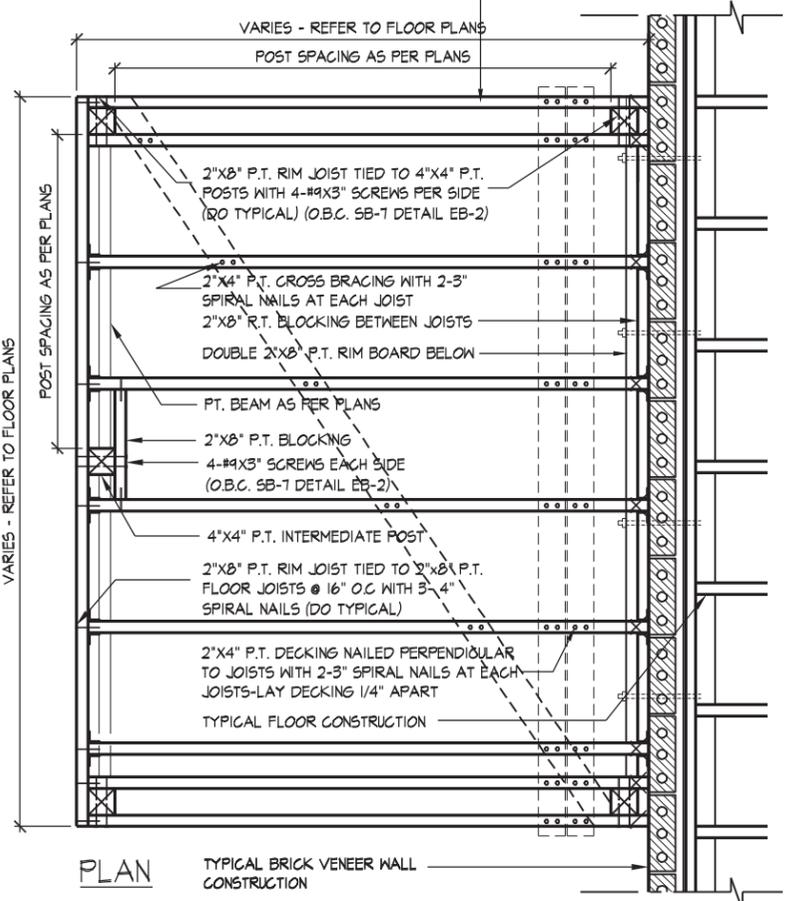

GENERAL NOTES  
 1. ALL CONSTRUCTION SHALL BE IN ACCORDANCE WITH THE O.B.C AND SB-7 OF THE SUPPLEMENTARY STANDARD  
 2. LUMBER GRADES SHALL NOT BE LESS THAN NO. 2 SPF. LUMBER SHALL BE FREE OF LOOSE KNOTS AND ALL CUT ENDS OF PRESERVATIVE TREATED LUMBER SHALL BE TREATED TO PREVENT DECAY  
 SPECIES FOR POSTS, PICKETS AND RAILS SHALL BE DOUGLAS FIR-LARCH, HEM-FIR, SPRUCE-PINE-FIR  
 3. ALL FASTENERS, SCREWS AND NAILS SHALL BE RESISTANT TO CORROSION - NAILS TO BE COMMON SPIRAL

08 TYP. DECK FRAMING ON WOOD LEDGER, BRICK VENEER

1/2" = 1'-0"



FOR STRUCTURAL ONLY EXCLUDING ENGINEERED ROOF TRUSS, FLOOR JOIST, FLOOR LVL BEAM DESIGNS.

DECK DETAILS 2

All drawings specifications related documents and design are the copyright property of Hunt Design Associates (H.D.A). Reproduction of this property in whole or in part is strictly prohibited without H.D.A.'s written permission (H.D.A. assumes no responsibility or liability for this property unless it bears the appropriate BCIN number and original signature).

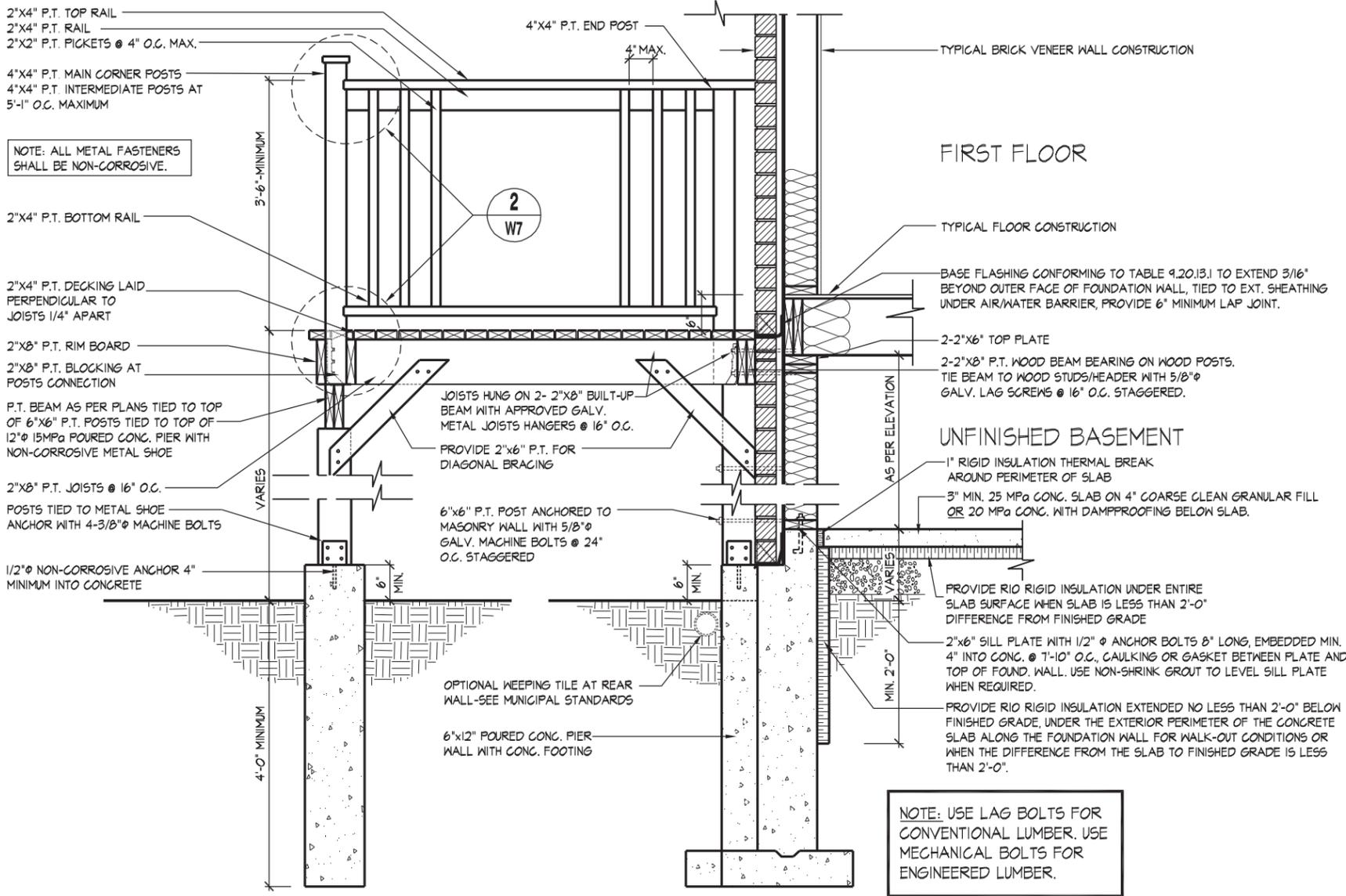

**09 MASONRY VENEER, TYPICAL WOOD DECK FOR WALK OUT BASEMENT**  
1/2" = 1'-0"

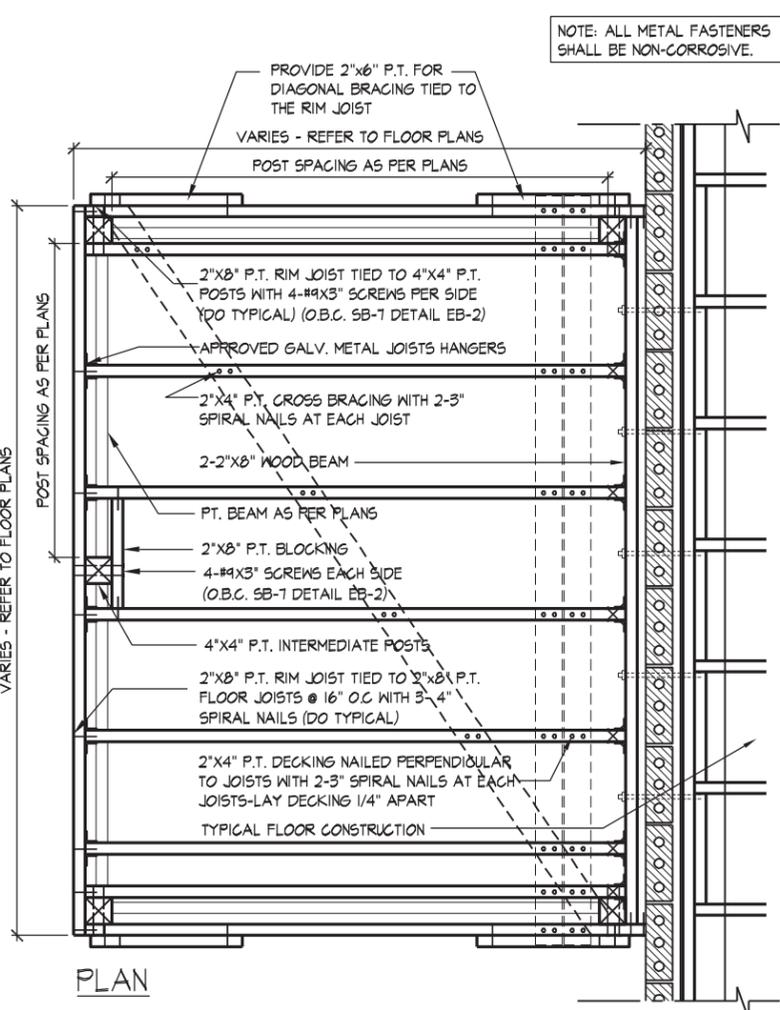

**10 MASONRY VENEER, TYPICAL DECK FRAMING PLAN**  
1/2" = 1'-0"

GENERAL NOTES  
 1. ALL CONSTRUCTION SHALL BE IN ACCORDANCE WITH THE O.B.C AND SB-7 OF THE SUPPLEMENTARY STANDARD  
 2. LUMBER GRADES SHALL NOT BE LESS THAN NO. 2 SPF. LUMBER SHALL BE FREE OF LOOSE KNOTS AND ALL CUT ENDS OF PRESERVATIVE TREATED LUMBER SHALL BE TREATED TO PREVENT DECAY SPECIES FOR POSTS, PICKETS AND RAILS SHALL BE DOUGLAS FIR-LARCH, HEM-FIR, SPRUCE-PINE-FIR  
 3. ALL FASTENERS, SCREWS AND NAILS SHALL BE RESISTANT TO CORROSION - NAILS TO BE COMMON SPIRAL

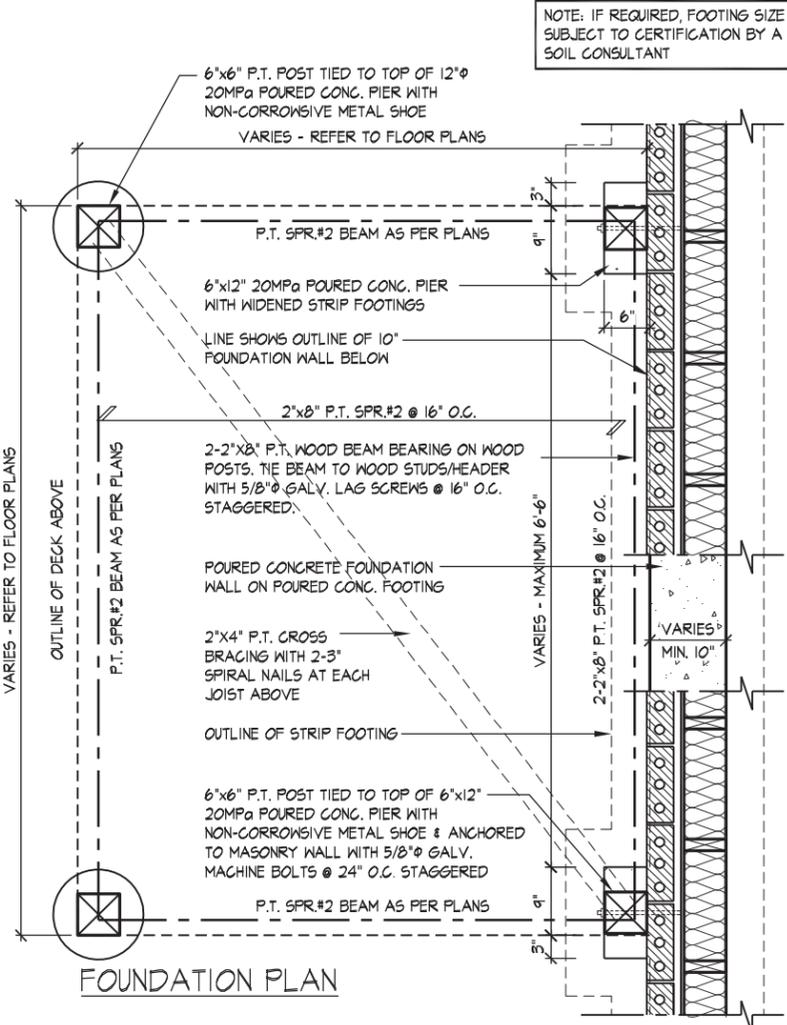

**11 MASONRY VENEER, TYPICAL DECK FOUNDATION PLAN**  
1/2" = 1'-0"



**DECK DETAILS 3**

**GOLDPARK HOMES - 217020 UNIT 4004 - THE DALERIDGE**  
PINE VALLEY, VAUGHAN ONT. REV. 2018/11/30

All drawings specifications related documents and design are the copyright property of Hunt Design Associates (H.D.A). Reproduction of this property in whole or in part is strictly prohibited without H.D.A.'s written permission (H.D.A. assumes no responsibility or liability for this property unless it bears the appropriate BCIN number and original signature).

NOTE: ALL METAL FASTENERS SHALL BE NON-CORROSIVE.

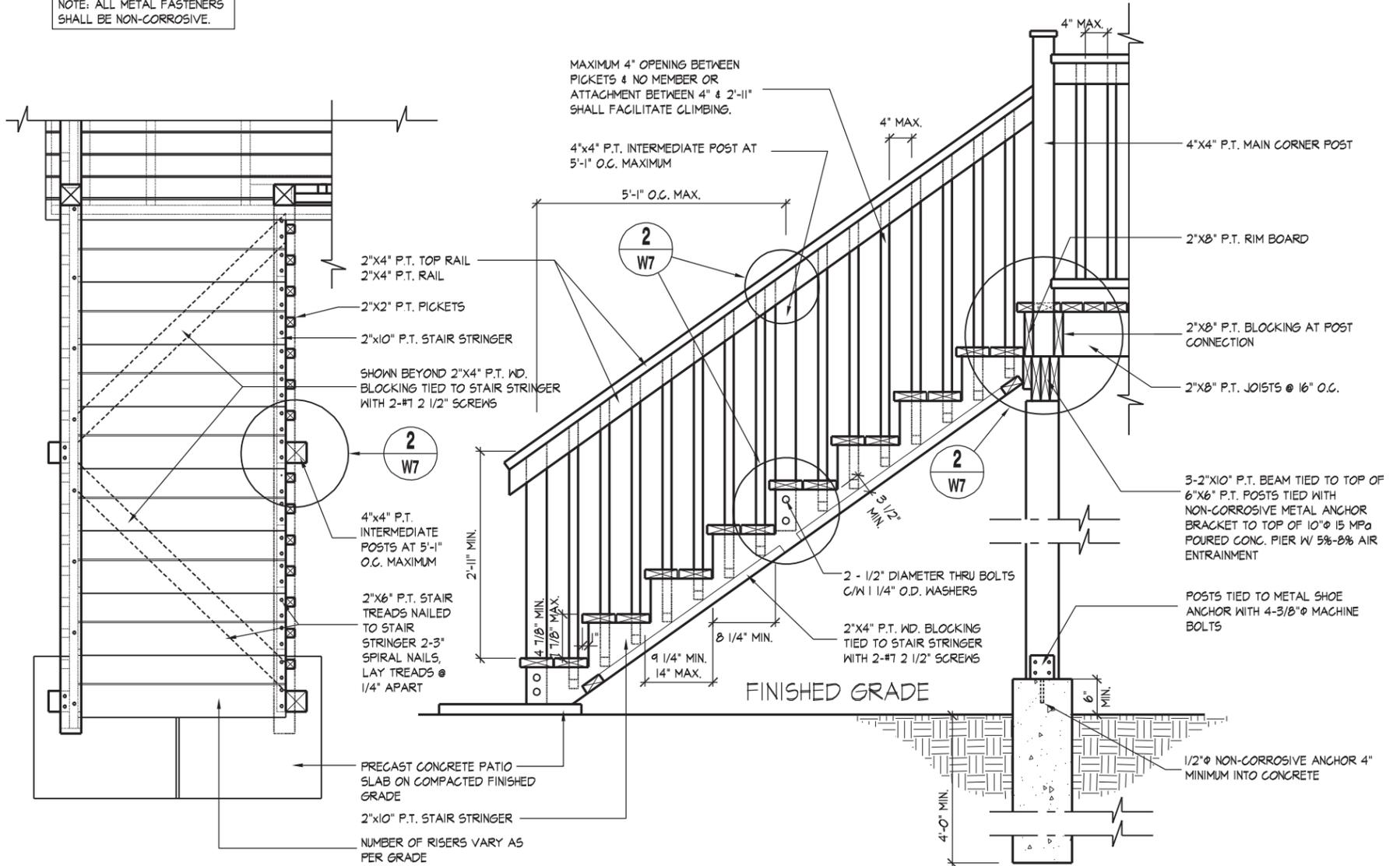

01 TYPICAL WOOD DECK STAIR  
1/2" = 1'-0"

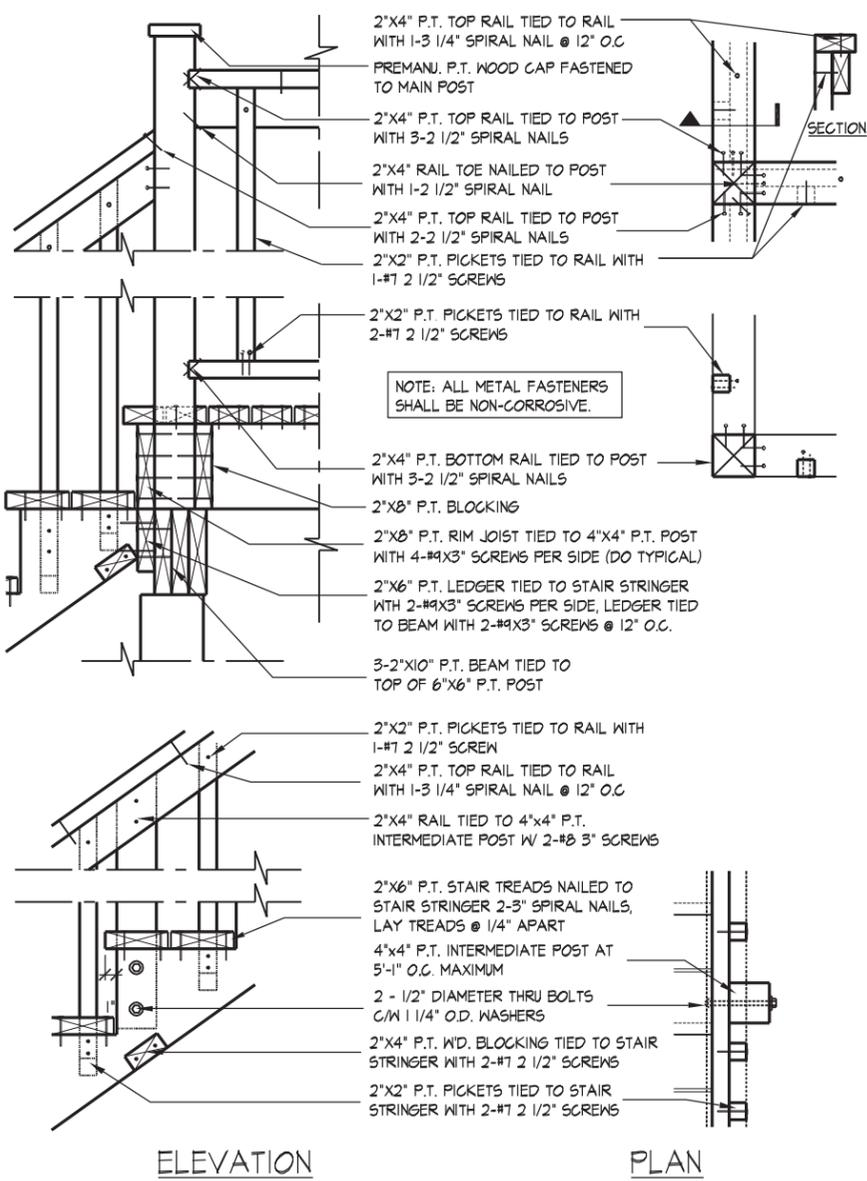

02 TYP. MAIN AND INTERMEDIATE POST ANCHORAGE  
3/4" = 1'-0"

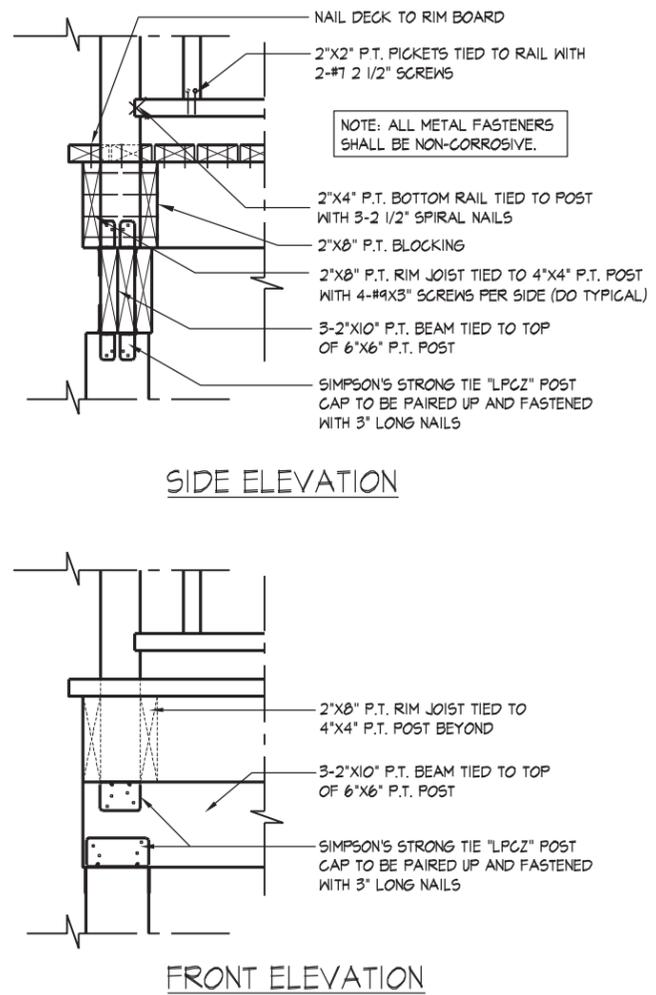

03 TYP. POST & BEAM CONNECTION  
3/4" = 1'-0"



THE UNDERSIGNED HAS REVIEWED AND TAKES RESPONSIBILITY FOR THIS DESIGN AND THE QUALIFICATIONS AND MEETS THE REQUIREMENTS SET OUT IN THE ONTARIO BUILDING CODE TO BE A DESIGNER.  
QUALIFICATION INFORMATION  
Olin Fairbairn  
NAME  
REGISTRATION INFORMATION  
HUNT DESIGN ASSOCIATES INC.  
20201  
BCN  
19695

HUNT DESIGN ASSOCIATES INC.  
www.huntdesign.ca

GOLDPARK HOMES - 217020 UNIT 4004 - THE DALERIDGE  
PINE VALLEY, VAUGHAN ONT.  
REV. 2018/11/30  
Drawn By HDAL/OV Checked By HDAL Scale 3/16" = 1'-0"  
File Number 217020WS4004-LOT 94 Page Number W7 of W7  
8966 Woodbine Ave, Markham, ON L3R 0J7 T 905.737.5133 F 905.737.7326

All drawings specifications related documents and design are the copyright property of Hunt Design Associates (H.D.A.). Reproduction of this property in whole or in part is strictly prohibited without H.D.A.'s written permission (H.D.A. assumes no responsibility or liability for this property unless it bears the appropriate BCIN number and original signature.)