

**APPLIANCES**

Invoice	Qty.	Description
2656 23Mar21 NoCat	1	APPLIANCE SPECIFICATIONS ATTACHED - SIGNED COPY
2691 15Apr21 NoCat	1	KITCHEN: UPGRADE TO 8" DUCT (EXTERIOR WALL) IN LIEU OF STANDARD OFFERING

**BASEMENT WINDOWS**

Invoice	Qty.	Description
2642 72,675 16Mar21	5	BASEMENT WINDOWS - UPGRADE BASEMENT WINDOW SIZE TO 30 " X 24" - 10" FRAME

**CERAMIC**

Invoice	Qty.	Description
2691 15Apr21 NoCat	1	MASTER ENSUITE: SHOWER BENCH COMPLETE WITH STANDARD TILE AND MATCHING MARBLE JAMB COLOUR SEAT TOP
2691 15Apr21 NoCat	1	**CUSTOM LAYOUT** MASTER ENSUITE: REVISE SIZE OF STANDARD VANITY TO ACCOMMODATE HIS AND HERS VANITIES - SEE PLAN
2691 15Apr21 NoCat	1	FYI - **CUSTOM LAYOUT** MASTER ENSUITE: DELETE STANDARD LINEN AS PER PLAN
2744 37 19May21	1	POWDER ROOM: TILE, FLOOR - LEVEL 5 - 12x24" LAID IN STRAIGHT STACKED PATTERN - SEE PLAN FOR DIRECTION
2744 37 19May21	1	MUD ROOM - TILE, FLOOR - LEVEL 5 - 12x24" LAID IN STRAIGHT STACKED PATTERN - SEE PLAN FOR DIRECTION
2744 39 19May21	1	FOYER: TILE, FLOOR - LEVEL 7 - 30x30" LAID IN STRAIGHT STACKED PATTERN
2744 39 19May21	1	MAIN HALL: TILE, FLOOR - LEVEL 7 - 30x30" LAID IN STRAIGHT STACKED PATTERN
2744 19 19May21	1	FOYER/MAIN HALL: TILE GROUT UPGRADE, FLOOR , UPG GROUT - FRONT FOYER/MAIN HALL - UPG GROUT
2744 19 19May21	1	POWDER ROOM: TILE GROUT UPGRADE, FLOOR , UPG GROUT

**CERAMIC**

Invoice	Qty.	Description
2744 19 19May21	1	MUD ROOM: TILE GROUT UPGRADE, FLOOR , UPG GROUT
2744 39 19May21	1	MASTER ENSUITE: TILE, FLOOR , LEVEL 7 - 30X30" LAID IN STRAIGHT, STACKED PATTERN.
2744 43 19May21	1	MASTER ENSUITE: TILE, SHOWER FLOOR, LEVEL 2
2744 19 19May21	1	MASTER ENSUITE - FLOOR / WALL / SHOWER FLOOR: TILE GROUT UPGRADE
2744 53 19May21	1	MASTER ENSUITE: TILE, WALL, LEVEL 5 - 12X24" LAID IN HORIZONTAL STACKED PATTERN
2744 19May21 NoCat	1	THRU OUT *FULLY INSTALL TILE BELOW ALL CABINETRY PLEASE*
2744 19May21 NoCat	1	KITCHEN/BREAKFAST: VINTAGE SERIES, 5" WHITE OAK, NSS ENGINEERED HARDWOOD, 3/4" THK, WIREBRUSH TEXTURE, UV OIL FINISH - LEVEL 3

**CONCRETE AND DRAIN**

Invoice	Qty.	Description
2642 101,930 16Mar21	1	BACK FLOW PREVENTER VALVE

**DRYWALL**

Invoice	Qty.	Description
2691 72,690 15Apr21 **	1	DELETE KITCHEN BULKHEAD, IF POSSIBLE, SITE APPROVAL REQUIRED
2691 15Apr21 NoCat	1	FRONT EXTERIOR: ADDITIONAL EXTERIOR COACH LIGHT ON SAME SWITCH (BUILDERS STANDARD FIXTURE)
2691 15Apr21 NoCat	1	LIBRARY: DELETE TWO STANDARD OPENINGS AS PER PLAN - INSTALL FULL HEIGHT WALLS
2691 15Apr21 NoCat	1	**CUSTOM LAYOUT** GARAGE: ADD MAN DOOR AT SIDE OF GARAGE - SEE PLAN
2691 15Apr21 NoCat	1	GREAT ROOM: UPGRADE MAIN FLOOR LINEAR 1 SIDED FIREPLACE - JADE SERIES 42" LINEAR DIRECT VENT GAS FIREPLACE IN LIEU OF STANDARD BOTTOM OF GLASS APPROX. 12" A.F.F. + ADD VENT GRILL APPROX. 6" FROM CEILING
2691 15Apr21 NoCat	1	DELETE KITCHEN BULKHEAD, IF POSSIBLE, SITE APPROVAL REQUIRED
2691 15Apr21 ** NoCat	1	DELETE KITCHEN BULKHEAD, IF POSSIBLE, SITE APPROVAL REQUIRED
2691 15Apr21 NoCat	1	MASTER ENSUITE: SHOWER BENCH COMPLETE WITH STANDARD TILE AND MATCHING MARBLE JAMB COLOUR SEAT TOP

**ELECTRICAL**

Invoice	Qty.	Description
2691 72,292 15Apr21	1	FRONT EXTERIOR: ADDITIONAL EXTERIOR COACH LIGHT ON SAME SWITCH (BUILDERS STANDARD FIXTURE)
2691 72,291 15Apr21	3	FRONT EXTERIOR: EXTERIOR LED SOFFIT POT LIGHT - SEE ATTACHED ELEVATION FOR LOCATION
2691 72,278 15Apr21	1	FOYER: ADDITIONAL INTERIOR SWITCH FOR EXTERIOR POT LIGHTS
2691 72,307 15Apr21	1	FOYER: RELOCATE STANDARD CEILING MOUNT FIXTURE TO BE APPROX. CENTERED IN CIRCULAR AREA OF CEILING - SEE PLAN
2691 72,307 15Apr21	1	MAIN HALL AT POWDER ROOM: RELOCATE STANDARD CEILING MOUNT FIXTURE TO BE APPROX. CENTERED IN CIRCULAR AREA OF CEILING - SEE PLAN
2691 72,287 15Apr21	1	DINING ROOM: ROUGH-IN FOR WALL SCONCE - INCLUDED (1) CAPPED OUTLET AND (1) SWITCH - FIXTURE NOT INCLUDED - INSTALL APPROX. 78" A.F.F. - SEE PLAN
2691 72,288 15Apr21	1	DINING ROOM: ROUGH-IN FOR ADDITIONAL WALL SCONCE (1) CAPPED OUTLET ON EXISTING SWITCH - FIXTURE NOT INCLUDED - INSTALL APPROX. 78" A.F.F. - SEE PLAN
2691 72,281 15Apr21	1	GARAGE: INTERIOR WALL OUTLET: ADDITIONAL 110V WALL INTERIOR RECEPTACLE ON EXISTING CIRCUIT - SEE PLAN
2691 72,286 15Apr21	1	LOGGIA: ADDITIONAL EXTERIOR GFI RECEPTACLE WITH COVER - SEE PLAN
2691 72,287 15Apr21	1	MASTER BEDROOM: ROUGH-IN FOR WALL SCONCE - INCLUDED (1) CAPPED OUTLET AND (1) SWITCH - FIXTURE NOT INCLUDED - APPROX. 52" A.F.F. AND APPROX. 37" IN FROM WALL - ADD SWITCH BELOW, APPROX. 36" A.F.F.
2691 72,268 15Apr21	1	MASTER BEDROOM: ROUGH-IN FOR WALL SCONCE - INCLUDED (1) CAPPED OUTLET AND (1) SWITCH - FIXTURE NOT INCLUDED - APPROX. 52" A.F.F. AND APPROX. 37" IN FROM WALL - ADD SWITCH BELOW, APPROX. 36" A.F.F.
2691 72,281 15Apr21	1	MASTER BEDROOM: INTERIOR WALL OUTLET: ADDITIONAL 110V WALL INTERIOR RECEPTACLE ON EXISTING CIRCUIT FOR WALL MOUNTED TV - APPROX. 60" A.F.F. - SEE PLAN
2691 72,307 15Apr21	1	KITCHEN: RELOCATE STANDARD CEILING MOUNT FIXTURE TO APPROX. CENTRE OVER ISLAND

**ELECTRICAL**

Invoice	Qty.	Description
2691 72,281 15Apr21	1	GREAT ROOM: INTERIOR WALL OUTLET: ADDITIONAL 110V WALL INTERIOR RECEPTACLE ON EXISTING CIRCUIT FOR WALL MOUNTED TV - APPROX. 64" A.F.F. ABOVE FIREPLACE
2691 72,307 15Apr21	1	UPPER HALL: RELOCATE STANDARD CEILING MOUNT FIXTURE TO APPROX. CENTRE ON CEILING AT OTB - SEE PLAN
2691 72,291 15Apr21	1	REAR EXTERIOR: EXTERIOR LED SOFFIT POT LIGHT - IN SOFFIT AT GREAT ROOM - ON EXISTING SWITCH W/ STD CEILING LIGHT AT LOGGIA - SEE PLAN
2691 72,288 15Apr21	1	UPPER HALL: ROUGH-IN FOR ADDITIONAL WALL SCONCE (1) CAPPED OUTLET ON EXISTING SWITCH - FIXTURE NOT INCLUDED - APPROX. 78" A.F.F. - APPROX CENTRE TO MAIN STAIRS - SEE PLAN
2691 72,288 15Apr21	1	STAIRS TO BASEMENT AT FIRST LANDING: ROUGH-IN FOR ADDITIONAL WALL SCONCE (1) CAPPED OUTLET ON EXISTING SWITCH - FIXTURE NOT INCLUDED - APPROX. 102" A.F.F.
2691 72,288 15Apr21	1	STAIRS AT LOWER BASEMENT LANDING: ROUGH-IN FOR ADDITIONAL WALL SCONCE (1) CAPPED OUTLET ON EXISTING SWITCH - FIXTURE NOT INCLUDED - APPROX. 78" A.F.F. - CONNECT TO 3-WAY SWITCH (SWITCH NOT INCLUDED)
2691 72,276 15Apr21	1	MAIN STAIRS: ADDITIONAL 3-WAY SWITCH (LIGHT OPERATED BY 2 DIFFERENT SWITCHES) - CONNECT TO ROUGH-IN WALL SCONCE AT LOWER LANDING TO BASEMENT
2691 72,276 15Apr21	1	MAIN STAIRS: ADDITIONAL 3-WAY SWITCH (LIGHT OPERATED BY 2 DIFFERENT SWITCHES) - CONNECT TO ROUGH-IN WALL SCONCE AT UPPER HALL
2691 72,307 15Apr21	1	UPPER HALL: RELOCATE STANDARD CEILING MOUNT FIXTURE TO CENTRE IN CIRCULAR AREA AT ENTRANCE TO MASTER BEDROOM
2691 72,289 15Apr21	6	MAIN HALL/FOYER: 4" E/S LED INTERIOR POT LIGHT - SEE PLAN - INCLUDES ONE SWITCH  INCLUDED IN APS
2691 72,307 15Apr21	1	MASTER ENSUITE: RELOCATE STANDARD CEILING MOUNT FIXTURE TO APPROX. CENTRE ON CEILING OVER FREE STANDING TUB + ADDITIONAL SWITCH
2691 15Apr21 NoCat	1	DINING ROOM: ADD SPLIT SWITCH
2691 72,278 15Apr21	1	MAIN HALL AT MUD ROOM: ADDITIONAL INTERIOR SWITCH FOR POT LIGHTS IN TWO MAIN HALL NICHES

**ELECTRICAL**

Invoice	Qty.	Description
2691 72,279 15Apr21	1	MASTER ENSUITE: SHOWER POT LIGHT: 6" RECESSED SHOWER POT LIGHT ON EXISTING SWITCH
2691 72,307 15Apr21	1	MASTER ENSUITE: RELOCATE STANDARD SHOWER POT LIGHT AS PER PLAN
2691 15Apr21 NoCat	1	LIBRARY: DELETE TWO STANDARD OPENINGS AS PER PLAN - INSTALL FULL HEIGHT WALLS
2691 15Apr21 NoCat	1	**CUSTOM LAYOUT** GARAGE: ADD MAN DOOR AT SIDE OF GARAGE - SEE PLAN
2691 15Apr21 NoCat	1	GREAT ROOM: UPGRADE MAIN FLOOR LINEAR 1 SIDED FIREPLACE - JADE SERIES 42" LINEAR DIRECT VENT GAS FIREPLACE IN LIEU OF STANDARD  BOTTOM OF GLASS APPROX. 12" A.F.F. + ADD VENT GRILL APPROX. 6" FROM CEILING

**FIREPLACE**

Invoice	Qty.	Description
2691 72,620 15Apr21	1	GREAT ROOM: UPGRADE MAIN FLOOR LINEAR 1 SIDED FIREPLACE - JADE SERIES 42" LINEAR DIRECT VENT GAS FIREPLACE IN LIEU OF STANDARD  BOTTOM OF GLASS APPROX. 12" A.F.F. + ADD VENT GRILL APPROX. 6" FROM CEILING

**FORMING**

Invoice	Qty.	Description
2642 72,560 16Mar21	1	MODEL OPTIONS 50.04 - KITCHEN REAR - OPT. COVERED LOGGIA AS PER PLAN
2642 101,930 16Mar21	1	OPTIONAL COLD CELLAR BELOW LOGGIA - SEE PLAN

**FRAMING**

Invoice	Qty.	Description
2691 101,930 15Apr21	1	LIBRARY: DELETE TWO STANDARD OPENINGS AS PER PLAN - INSTALL FULL HEIGHT WALLS
2691 72,690 15Apr21	1	DELETE KITCHEN BULKHEAD, IF POSSIBLE, SITE APPROVAL REQUIRED
2691 72,671 15Apr21	1	MASTER ENSUITE: SHOWER BENCH COMPLETE WITH STANDARD TILE AND MATCHING MARBLE JAMB COLOUR SEAT TOP
2691 15Apr21 NoCat	1	FRONT EXTERIOR: ADDITIONAL EXTERIOR COACH LIGHT ON SAME SWITCH (BUILDERS STANDARD FIXTURE)
2691 15Apr21 NoCat	1	**CUSTOM LAYOUT** GARAGE: ADD MAN DOOR AT SIDE OF GARAGE - SEE PLAN
2691 15Apr21 NoCat	1	**CUSTOM LAYOUT** GARAGE: ADD MAN DOOR AT SIDE OF GARAGE - SEE PLAN
2691 15Apr21 NoCat	1	FRONT EXTERIOR: EXTERIOR LED SOFFIT POT LIGHT - SEE ATTACHED ELEVATION FOR LOCATION
2691 15Apr21 NoCat	1	GREAT ROOM: UPGRADE MAIN FLOOR LINEAR 1 SIDED FIREPLACE - JADE SERIES 42" LINEAR DIRECT VENT GAS FIREPLACE IN LIEU OF STANDARD BOTTOM OF GLASS APPROX. 12" A.F.F. + ADD VENT GRILL APPROX. 6" FROM CEILING
2691 15Apr21 NoCat	1	LOGGIA: ADDITIONAL EXTERIOR GFI RECEPTACLE WITH COVER - SEE PLAN
2691 15Apr21 ** NoCat	1	DELETE KITCHEN BULKHEAD, IF POSSIBLE, SITE APPROVAL REQUIRED
2691 15Apr21 ** NoCat	1	DELETE KITCHEN BULKHEAD, IF POSSIBLE, SITE APPROVAL REQUIRED
2691 15Apr21 NoCat	1	REAR EXTERIOR: EXTERIOR LED SOFFIT POT LIGHT - IN SOFFIT AT GREAT ROOM - ON EXISTING SWITCH W/ STD CEILING LIGHT AT LOGGIA - SEE PLAN

**GLASS AND MIRROR**

Invoice	Qty.	Description
2744 19May21 NoCat	1	MASTER ENSUITE: SQ6X6 - BRUSHED GOLD + HINGES
2744 19May21 NoCat	1	THRU OUT: PLEASE DO NOT INSTALL MIRRORS
2744 19May21 NoCat	2	ENSUITE 2 + ENSUITE 4: UPGRADE SHOWER DOOR HARDWARE AND HINGES TO MATTE BLACK

**GRANITE MARBLE QUARTZ**

Invoice	Qty.	Description
2744 19May21 NoCat	1	POWDER ROOM: UPGRADE 1 QUARTZ COUNTER
2744 19May21 NoCat	1	MASTER ENSUITE: UPGRADE QUARTZ TO SHOWER BENCH *only* UPGRADE 1  VANITY COUNTER TOPS TO BE STANDARD
2957 11Jan22 NoCat	1	<b>**REVISED SELECTION: DECEMBER 20 2021**</b> MASTER ENSUITE: CHANGE *BOTH* COUNTER TOP SELECTION TO 3CM LEVEL 6 QUARTZ + WATERFALL LEGS ON BOTH SIDES OF VANITIES
2957 11Jan22 NoCat	1	<b>**REVISION** JAN 10 2022 (modify previous selection # 24 pe.2744)</b> MASTER ENSUITE: CHANGE SHOWER JAMB AND BENCH TO BLACK  in addition to price, item 24 pe.2744

**HARDWOOD**

Invoice	Qty.	Description
2744 4 19May21	1	KITCHEN/BREAKFAST: VINTAGE SERIES, 5" WHITE OAK, NSS ENGINEERED HARDWOOD, 3/4" THK, WIREBRUSH TEXTURE, UV OIL FINISH - LEVEL 3
2744 4 19May21	1	THRU OUT STD AREAS: LIBRARY, DINING ROOM, GREAT ROOM, UPPER HALL, MASTER BEDROOM, BEDROOM 2, BEDROOM 3, BEDROOM 4 - VINTAGE SERIES, 5" WHITE OAK, NSS ENGINEERED HARDWOOD, 3/4" THK, WIREBRUSH TEXTURE, UV OIL FINISH - LEVEL 3 NOT MAIN HALL
2744 4 19May21	1	KITCHEN/BREAKFAST/SERVERY: HARDWOOD IN HERRINGBONE PATTERN  5X30" HERRINGBONE



**HVAC**

Invoice	Qty.	Description
2691 101,930 15Apr21	1	LOGGIA: SEE PLAN FOR PREFERRED ROUGH-IN BBQ LOCATION
2691 72,217 15Apr21	1	KITCHEN: UPGRADE TO 8" DUCT (EXTERIOR WALL) IN LIEU OF STANDARD OFFERING
2691 72,690 15Apr21 **	1	DELETE KITCHEN BULKHEAD, IF POSSIBLE, SITE APPROVAL REQUIRED
2691 15Apr21 NoCat	1	GREAT ROOM: UPGRADE MAIN FLOOR LINEAR 1 SIDED FIREPLACE - JADE SERIES 42" LINEAR DIRECT VENT GAS FIREPLACE IN LIEU OF STANDARD  BOTTOM OF GLASS APPROX. 12" A.F.F. + ADD VENT GRILL APPROX. 6" FROM CEILING
2691 15Apr21 ** NoCat	1	DELETE KITCHEN BULKHEAD, IF POSSIBLE, SITE APPROVAL REQUIRED
2691 15Apr21 ** NoCat	1	DELETE KITCHEN BULKHEAD, IF POSSIBLE, SITE APPROVAL REQUIRED

**INTERIOR TRIM AND DOORS**

Invoice	Qty.	Description
2691 15Apr21 NoCat	1	LIBRARY: DELETE TWO STANDARD OPENINGS AS PER PLAN - INSTALL FULL HEIGHT WALLS
2691 15Apr21 NoCat	1	**CUSTOM LAYOUT** MASTER ENSUITE: REVISE SIZE OF STANDARD VANITY TO ACCOMMODATE HIS AND HERS VANITIES - SEE PLAN
2691 15Apr21 NoCat	1	FYI - **CUSTOM LAYOUT** MASTER ENSUITE: DELETE STANDARD LINEN AS PER PLAN
2744 155,410 19May21	1	THRU OUT: UPGRADE INTERIOR DOORS TO LINCOLN PARK, UPGRADE
2744 153,836 19May21	1	THRU OUT: HALIFAX LEVER, IRON BLACK INTERIOR DOOR HARDWARE UPGRADE
2744 155,917 19May21	1	THRU OUT: ADD FOR HINGES 3X3 SQUARE FLAT TIP THROUGHOUT UPGRADE
2744 153,551 19May21	1	THRU OUT: UPGRADE 3 1/4" STEP BEVEL BB CASING, 7 1/4" BASE BOARD UPGRADE

**KITCHEN AND BATH CABINetry**

Invoice	Qty.	Description
2691 72,690 15Apr21 **	1	DELETE KITCHEN BULKHEAD, IF POSSIBLE, SITE APPROVAL REQUIRED
2691 101,930 15Apr21	1	**CUSTOM LAYOUT** MASTER ENSUITE: REVISE SIZE OF STANDARD VANITY TO ACCOMMODATE HIS AND HERS VANITIES - SEE PLAN
2691 101,930 15Apr21	1	**CUSTOM LAYOUT** MASTER ENSUITE: DELETE STANDARD LINEN AS PER PLAN
2691  15Apr21 NoCat	1	FYI - KITCHEN: UPGRADE TO 8" DUCT (EXTERIOR WALL) IN LIEU OF STANDARD OFFERING
2691  15Apr21 ** NoCat	1	DELETE KITCHEN BULKHEAD, IF POSSIBLE, SITE APPROVAL REQUIRED
2691  15Apr21 ** NoCat	1	DELETE KITCHEN BULKHEAD, IF POSSIBLE, SITE APPROVAL REQUIRED
2744 156,625 19May21	1	THRU OUT: SEE ATTACHED CABINetry SCHEDULE

**MASONRY**

Invoice	Qty.	Description
2691  15Apr21 NoCat	1	FRONT EXTERIOR: ADDITIONAL EXTERIOR COACH LIGHT ON SAME SWITCH (BUILDERS STANDARD FIXTURE)
2691  15Apr21 NoCat	1	**CUSTOM LAYOUT** GARAGE: ADD MAN DOOR AT SIDE OF GARAGE - SEE PLAN

**MISC.**

Invoice	Qty.	Description
2957  11Jan22 NoCat	1	ADMIN FEE TO RE-OPEN FILE

**NETWORK AND WIRING**

Invoice	Qty.	Description
2691 72,259 15Apr21	1	GREAT ROOM: CONDUIT PIPE - FOR WALL MOUNT TV - APPROX. 64" A.F.F. ABOVE FIREPLACE, THRU BASEMENT, TERMINATE AT CABLE LOCATION
2691 72,260 15Apr21	1	CONDUIT PIPE - FROM ATTIC TO BASEMENT - BY ELECTRICAL PANEL IN BASEMENT TO APPROX. CENTRE IN ATTIC
2691 72,264 15Apr21	1	LAUNDRY ROOM: ROUGH - IN FOR EXTRA SECURITY KEY PAD
2691 72,264 15Apr21	1	MUD ROOM: ROUGH - IN FOR EXTRA SECURITY KEY PAD
2691 72,265 15Apr21	1	GREAT ROOM: ROUGH - IN WIRING FOR FIVE SPEAKERS
2691 72,265 15Apr21	1	MASTER ENSUITE: ROUGH - IN WIRING FOR ONE PAIR OF SPEAKERS - SEE PLAN FOR LOCATION
2691 72,265 15Apr21	1	KITCHEN: ROUGH - IN WIRING FOR ONE PAIR OF SPEAKERS - SEE PLAN FOR LOCATION
2691 72,265 15Apr21	1	LOGGIA: ROUGH - IN WIRING FOR ONE PAIR OF SPEAKERS - SEE PLAN FOR LOCATION
2691 72,258 15Apr21	5	EXTERIOR: ADDITIONAL CAT6 ETHERNET OUTLET - FOR FUTURE SECURITY CAMERAS - INSTALL IN THE UNDERSIDE OF SOFFIT OF FIRST FLOOR - APPROX. 10-12' ABOVE GRADE - SEE PLAN
2691 72,258 15Apr21	1	FRONT EXTERIOR: ADDITIONAL CAT6 ETHERNET OUTLET - FOR FUTURE SECURITY CAMERA - INSTALL IN THE UNDERSIDE OF SOFFIT AT GARAGE - SEE PLAN
2691 72,258 15Apr21	1	GREAT ROOM: ADDITIONAL CAT6 ETHERNET OUTLET - EACH - SEE PLAN
2691 72,258 15Apr21	1	LIBRARY: ADDITIONAL CAT6 ETHERNET OUTLET - EACH - SEE PLAN
2691 72,258 15Apr21	4	MASTER BEDROOM + BEDROOM 2 + BEDROOM 3 + BEDROOM 4: ADDITIONAL CAT6 ETHERNET OUTLET - EACH - SEE PLAN

**NETWORK AND WIRING**

Invoice	Qty.	Description
2691 72,258 15Apr21	3	BEDROOM 2 + BEDROOM 3 + BEDROOM 4: ADDITIONAL RG6 - EACH - SEE PLAN

**PAINT**

Invoice	Qty.	Description
2691 15Apr21 NoCat	1	LIBRARY: DELETE TWO STANDARD OPENINGS AS PER PLAN - INSTALL FULL HEIGHT WALLS
2691 15Apr21 NoCat	1	**CUSTOM LAYOUT** GARAGE: ADD MAN DOOR AT SIDE OF GARAGE - SEE PLAN
2691 15Apr21 NoCat	1	**CUSTOM LAYOUT** MASTER ENSUITE: REVISE SIZE OF STANDARD VANITY TO ACCOMMODATE HIS AND HERS VANITIES - SEE PLAN
2691 15Apr21 NoCat	1	FYI -**CUSTOM LAYOUT** MASTER ENSUITE: DELETE STANDARD LINEN AS PER PLAN
2744 100,309 19May21	2	MAIN STAIRS: 2ND FLOOR TO BASEMENT - STAIN STAIRS AND LANDINGS  WILL NOT MATCH HARDWOOD IN COLOUR, SPECIES OR TEXTURE

**PAINTING**

Invoice	Qty.	Description
2691 72,690 15Apr21 **	1	DELETE KITCHEN BULKHEAD, IF POSSIBLE, SITE APPROVAL REQUIRED
2691 15Apr21 ** NoCat	1	DELETE KITCHEN BULKHEAD, IF POSSIBLE, SITE APPROVAL REQUIRED
2691 15Apr21 ** NoCat	1	DELETE KITCHEN BULKHEAD, IF POSSIBLE, SITE APPROVAL REQUIRED
2957 11Jan22 NoCat	1	<b>**REVISED SELECTION - DECEMBER 20 2021**</b> <b>MAIN STAIRS - CHANGE STAIR STAIN COLOUR IN LIEU OF PREVIOUS SELECTION</b>

**PANL - FRAMING**

Invoice	Qty.	Description
2691 72,690 15Apr21 **	1	DELETE KITCHEN BULKHEAD, IF POSSIBLE, SITE APPROVAL REQUIRED
2691 15Apr21 ** NoCat	1	DELETE KITCHEN BULKHEAD, IF POSSIBLE, SITE APPROVAL REQUIRED
2691 15Apr21 ** NoCat	1	DELETE KITCHEN BULKHEAD, IF POSSIBLE, SITE APPROVAL REQUIRED

**PLUMBING**

Invoice	Qty.	Description
2744 19May21 NoCat	1	POWDER ROOM: UPGRADE TO 'EMERY' BLACK RECTANGULAR UNDER MOUNT SINK

**PLUMBING FIXTURE**

Invoice	Qty.	Description
2691 75,857 15Apr21	1	MASTER ENSUITE: ADD MOEN ALIGN RAIN SHOWER FROM CEILING - CHROME - IN ADDITION TO STANDARD STANDARD SHOWER FAUCET TO REMAIN

**STAIR AND RAILINGS**

Invoice	Qty.	Description
2744 100,252 19May21	1	MAIN STAIRS: ADD FOR GLASS PANEL IN LIEU OF PICKETS - UPG - GLASS PANEL

**WINDOWS AND DOORS**

Invoice	Qty.	Description
2691 72,364 15Apr21	1	**CUSTOM LAYOUT** GARAGE: ADD MAN DOOR AT SIDE OF GARAGE - SEE PLAN GRADE PERMITTING

\*\*\* NOTE: This is not an approved document. Document must be locked \*\*\*

Scheduled Closing Date: Thursday, November 25, 2021

Purchasers: LAURA, GIUSEPPINA PELOSO & ANTHONY, AI Property: 85 of Plan -

Telephone Res. / Bus: (416) 669-8574 / (416) 669-8574

Project: Pine Valley Forevergreen - Phase 1

Decor Advisor: Amanda Ceresino

Model and Elevation: 50.04 C BEAUMONT

Layout Changes:  Yes  No Sketch Attached:  Yes  No Exterior Colour Scheme:

### 1. Cabinetry

	Style and Colour	Counter	Hardware
Kitchen / Breakfast	Chesapeake 'Classic White'	Granite: Arctic White	attachd
Laundry Room	Bowery 'Capri'	P-Lam: White	attachd
Powder Room	Bowery 'Capri'	*Quartz: Jet Black	attachd
Mud Room	Tribeca 'Arris'	P-Lam: White	attachd
Master Ensuite Bathroom	Bowery 'Capri'	Quartz: Ice Snow * ETERNAL NOISE + WATERFALL - 3CM.	attachd
Second Ensuite Bathroom (If Applicable)	Bowery 'Capri'	Quartz: Ice Snow	attachd
Ensuite 3	Tribeca 'Arris'	Quartz: Ice Snow	attachd

#### Comment

Ensuite 4: Bowery 'Ello' + Ice Snow // ~~MASTER ENSUITE SHOWER BENCH: \*QUARTZ: JET BLACK~~

↳ MASTER ENSUITE SHOWER BENCH + JAMB "BLACK"

REVISED: JAN 10 2022.

attach

### 2. Floor Tile

	Selection
Entrance Vestibule	*30x30" Marmorea 'Port Laurent' matte + see grout attached charcoal
Main Hall	*30x30" Marmorea 'Port Laurent' matte + see grout attached charcoal
Kitchen / Breakfast	see hdwd
Laundry Room	13x13" Costa 'White'
Powder Room	*12x24" Marmorea 'Port Laurent' matte + see grout attached charcoal
Mud Room	*12x24" Marmorea 'Port Laurent' matte + see grout attached charcoal
Master Ensuite Bathroom	*30x30" Marmorea 'Port Laurent' matte + see grout attached charcoal
Second Ensuite Bathroom (If Applicable)	13x13" Costa 'White'
Lower Landing (If Applicable)	13x13" Costa 'White' (basement foyer)
Ensuite 3	13x13" Costa 'White'

#### Comment

Ensuite 4: 13x13" Cambridge 'White' // Shower Floor tile: std 2x2" white for ensuite 2/3/4 // Master Ensuite Shower floor: \*2" Ont matte 'black'

1x1" Basic Black matte hex + charcoal grout

### 3. Wall Tile

	Selection	Listello/Inserts	Describe
Ensuite 3	8x10: Weave 'White'	<input type="radio"/> Yes <input checked="" type="radio"/> No	
Master Ensuite Bathroom			
Tub Deck		<input type="radio"/> Yes <input checked="" type="radio"/> No	
Shower Stall	*12X24" Marmorea mt 'P.Laurent'	<input type="radio"/> Yes <input checked="" type="radio"/> No	
Bathroom Walls		<input type="radio"/> Yes <input checked="" type="radio"/> No	
Second Ensuite Bathroom (If Applicable)	8x10" Uniwall 'White'	<input type="radio"/> Yes <input checked="" type="radio"/> No	
Ensuite 4	8x10" Uniwall 'White'	<input type="radio"/> Yes <input checked="" type="radio"/> No	
Kitchen Backsplash	<input type="radio"/> Yes <input checked="" type="radio"/> No	Backsplash Behind Fridge	<input type="text"/>

#### Comment

\* REVISED - DEC 15 2021 AJ JP

REVISED MAY 5 2021

attach

\*\*\* NOTE: This is not an approved document. Document must be locked \*\*\*

Scheduled Closing Date: Thursday, November 25, 2021

Purchasers: LAURA, GIUSEPPINA PELOSO & ANTHONY, AI Property: 85 of Plan -

Telephone Res. / Bus: (416) 669-8574 / (416) 669-8574

Project: Pine Valley Forevergreen - Phase 1

Decor Advisor: Amanda Ceresino

Model and Elevation: 50.04 C BEAUMONT

### 4. Plumbing Fixtures

<input type="checkbox"/>	Second Ensuite	<input type="checkbox"/>	Powder Room	<input type="checkbox"/>
Master Ensuite Bathroom	<input type="checkbox"/>	Other Room - Specify	<input type="checkbox"/>	Other Washroom
Comment	<input type="text"/>			

upgraded thru out - see extras

### 5. Hardwood Flooring

	Type and Stain		Type and Stain
Main Hall	<input type="text"/>	Upper Landing	<input type="text"/>
Kitchen / Breakfast	3/4x5" wht oak wirebrush 'Atlantis'	Upper Hall	<input type="text"/>
Living Room	<input type="text"/>	Master Bedroom	<input type="text"/>
Dining Room	<input type="text"/>	Bedroom #2	<input type="text"/>
Family Room	<input type="text"/>	Bedroom #3	<input type="text"/>
Den/Library	<input type="text"/>	Bedroom #4	<input type="text"/>
Entrance Vestibule	<input type="text"/>	Bedroom #5	<input type="text"/>
Lower Landing (If Applicable)	<input type="text"/>	Other Room - Specify	<input type="text"/>
Comment	thru out standard areas 3/4x5" wht oak wirebrush 'Atlantis'		

\*\*5x30" HERRINGBONE IN KITCHEN/BREAKFAST/SERVERY\*\*

### 6. Carpeting

	Upgrade	Description
Ground Floor	<input type="checkbox"/>	<input type="text"/>
Second Floor	<input type="checkbox"/>	<input type="text"/>
<input type="text"/>	<input type="checkbox"/>	<input type="text"/>

Upgrade Underpad	Type	Area
	<input type="text"/>	<input type="text"/>
Carpet on Stairs	Capped	Runner - *Upgrade
	<input type="text"/>	<input type="text"/>

Comment

### 7. Fireplace

	Living Room			Family Room			Other Room - Specify		
	Purchased	As Per Plan	N/A	Purchased	As Per Plan	N/A	Purchased	As Per Plan	N/A
Fireplace Type	<input type="radio"/>	<input type="radio"/>	<input type="radio"/>	<input type="radio"/>	<input checked="" type="radio"/>	<input type="radio"/>	<input type="radio"/>	<input type="radio"/>	<input type="radio"/>
Mantle Type	<input type="text"/>	<input type="text"/>	<input type="text"/>	Linear	<input type="text"/>	<input type="text"/>	<input type="text"/>	<input type="text"/>	<input type="text"/>
Colour / Stain	<input type="text"/>	<input type="text"/>	<input type="text"/>	None	<input type="text"/>	<input type="text"/>	<input type="text"/>	<input type="text"/>	<input type="text"/>
Surround	<input type="text"/>	<input type="text"/>	<input type="text"/>	N/A	<input type="text"/>	<input type="text"/>	<input type="text"/>	<input type="text"/>	<input type="text"/>
Hearth	<input type="text"/>	<input type="text"/>	<input type="text"/>	N/A	<input type="text"/>	<input type="text"/>	<input type="text"/>	<input type="text"/>	<input type="text"/>
Comment	<input type="text"/>								

REVISED: JAN 10 2022 attached

attached



\*\*\* NOTE: This is not an approved document. Document must be locked \*\*\*

Scheduled Closing Date: Thursday, November 25, 2021

Purchasers: LAURA, GIUSEPPINA PELOSO & ANTHONY, AI Property: 85 of Plan -

Telephone Res. / Bus: (416) 669-8574 / (416) 669-8574

Project: Pine Valley Forevergreen - Phase 1

Decor Advisor: Amanda Ceresino

Model and Elevation: 50.04 C BEAUMONT

**8. Trim Carpentry**

Interior Doors  Front Door Glass Inserts  Door Handles   
Interior Trim

Comment

**9. Plaster Mouldings and Medallions**

Standard Throughout  Yes  No  N/A

Entrance Vestibule	<input type="text"/>	<input type="text"/>	Kitchen/Breakfast	<input type="text"/>	<input type="text"/>
Main Hall	<input type="text"/>	<input type="text"/>	Den/Library	<input type="text"/>	<input type="text"/>
Living Room	<input type="text"/>	<input type="text"/>	Lower Landing	<input type="text"/>	<input type="text"/>
Dining Room	<input type="text"/>	<input type="text"/>	Other Room - Specify	<input type="text"/>	<input type="text"/>
Family Room	<input type="text"/>	<input type="text"/>		<input type="text"/>	<input type="text"/>

Comment

**10. Railings and Spindles**

Railing Package   
Railing Colour   
Stringer / Riser   
Spindle Colour   
Treads   
Oak Stairs  Yes  No  N/A

Comment

**11. Wall Paint / Ceilings**

Throughout Finished Areas

Trim Paint

Smooth Ceilings

Ground Floor

Second Floor

Note

Comment

*REVISED: JAN 10 2022 attached*

*attached*

\*\*\* NOTE: This is not an approved document. Document must be locked \*\*\*

Scheduled Closing Date: Thursday, November 25, 2021

Purchasers: LAURA, GIUSEPPINA PELOSO & ANTHONY, AI Property: 85 of Plan -

Telephone Res. / Bus: (416) 669-8574 / (416) 669-8574

Project: Pine Valley Forevergreen - Phase 1

Decor Advisor: Amanda Ceresino

Model and Elevation: 50.04 C BEAUMONT

### 12. Electrical

Hood Fan  White  Stainless  N/A

Above Kitchen Cabinet Light  Yes  No

Standard Appliances

Below Kitchen Cabinet Light  Yes  No

Over The Range Microwave

Chimney Style Fan

Comment

### 13. Heating and Air Conditioning

Air Conditioning

Gas Provisions Stove

Gas Provisions Dryer

Gas Provisions Barbecue

Comment

### 14. Additional Comments

### 15. Disclaimers and Notes

- 1) Colours of all materials are as close as possible to builder's selection, but not necessarily identical due to variances in manufacturing.
- 2) Any extras listed above are null and void unless accompanied by a separate invoice/amendment. Said invoice must be paid in full.
- 3) The Purchaser acknowledges that after Interior Colour Selection form is signed and dated, no further changes will be permitted other than re-selection due to unavailability. \_\_\_\_\_ Purchaser's Initials
- 4) The Purchaser acknowledges reading and accepting the "Gold Park Homes Decor Centre Disclaimers" form. This document contains other miscellaneous disclaimers.

This Interior Colour Selection is final and approved by:

Signature: attached Date: \_\_\_\_\_

*REUSED: JAN 10 2022 attached*

\*\*\* NOTE: This is not an approved document. Document must be locked \*\*\*

Scheduled Closing Date: Thursday, November 25, 2021

Purchasers: LAURA, GIUSEPPINA PELOSO & ANTHONY, AI Property: 85 of Plan -

Telephone Res. / Bus: (416) 669-8574 / (416) 669-8574

Project: Pine Valley Forevergreen - Phase 1

Decor Advisor: Amanda Ceresino

Model and Elevation: 50.04 C BEAUMONT

Layout Changes:  Yes  No Sketch Attached:  Yes  No Exterior Colour Scheme: \_\_\_\_\_

1. Cabinetry

	Style and Colour	Counter	Hardware
Kitchen / Breakfast	Chesapeake 'Classic White'	Granite: Arctic White	attachd
Laundry Room	Bowery 'Capri'	P-Lam: White	attachd
Powder Room	Bowery 'Capri'	*Quartz: Jet Black	attachd
Mud Room	Tribeca 'Arris'	P-Lam: White	attachd
Master Ensuite Bathroom	Bowery 'Capri'	Quartz: Ice Snow * F. EKNAI NOISE + WATERFALL - 3CM	attachd
Second Ensuite Bathroom (If Applicable)	Bowery 'Capri'	Quartz: Ice Snow	attachd
Ensuite 3	Tribeca 'Arris'	Quartz: Ice Snow	attachd

Comment

Ensuite 4: Bowery 'Elio' + Ice Snow // MASTER ENSUITE SHOWER BENCH: \*QUARTZ: JET BLACK

↳ MASTER ENSUITE SHOWER BENCH + JALIS "BLACK"

REVISED: JAN 10 2022

*AY*

2. Floor Tile

	Selection
Entrance Vestibule	*30x30" Marmorea 'Port Laurent' matte + see grout attached <i>charcoal</i>
Main Hall	*30x30" Marmorea 'Port Laurent' matte + see grout attached <i>charcoal</i>
Kitchen / Breakfast	see hdwd
Laundry Room	13x13" Costa 'White'
Powder Room	*12x24" Marmorea 'Port Laurent' matte + see grout attached <i>charcoal</i>
Mud Room	*12x24" Marmorea 'Port Laurent' matte + see grout attached <i>charcoal</i>
Master Ensuite Bathroom	*30x30" Marmorea 'Port Laurent' matte + see grout attached <i>charcoal</i>
Second Ensuite Bathroom (If Applicable)	13x13" Costa 'White'
Lower Landing (If Applicable)	13x13" Costa 'White' (basement foyer)
Ensuite 3	13x13" Costa 'White'

Comment

Ensuite 4: 13x13" Cambridge 'White' // Shower Floor tile: std 2x2" white for ensuite 2/3/4 // Master Ensuite Shower floor: \*2" Ort matte black

1x1" Basic Black matte hex + charcoal grout

3. Wall Tile

	Selection	Listello/Inserts	Describe
Ensuite 3	8x10: Weave 'White'	<input type="radio"/> Yes <input checked="" type="radio"/> No	
Master Ensuite Bathroom			
Tub Deck		<input type="radio"/> Yes <input checked="" type="radio"/> No	
Shower Stall	*12X24" Marmorea mt 'P.Laurent'	<input type="radio"/> Yes <input checked="" type="radio"/> No	
Bathroom Walls		<input type="radio"/> Yes <input checked="" type="radio"/> No	
Second Ensuite Bathroom (If Applicable)	8x10" Uniwall 'White'	<input type="radio"/> Yes <input checked="" type="radio"/> No	
Ensuite 4	8x10" Uniwall 'White'	<input type="radio"/> Yes <input checked="" type="radio"/> No	
Kitchen Backsplash	<input type="radio"/> Yes <input checked="" type="radio"/> No	Backsplash Behind Fridge	

Comment

\* REVISED - DEC 15 2021 *AY*

REVISED MAY 5 2021 *attached*

\*\*\* NOTE: This is not an approved document. Document must be locked \*\*\*

Scheduled Closing Date: Thursday, November 25, 2021

Purchasers: LAURA, GIUSEPPINA PELOSO & ANTHONY, At Property: 85 of Plan -

Telephone Res. / Bus: (416) 669-8574 / (416) 669-8574

Project: Pine Valley Forevergreen - Phase 1

Decor Advisor: Amanda Ceresino

Model and Elevation: 50.04 C BEAUMONT

4. Plumbing Fixtures

Master Ensuite Bathroom	<input type="checkbox"/>	Second Ensuite	<input type="checkbox"/>	Powder Room	<input type="checkbox"/>
	<input type="checkbox"/>	Other Room - Specify	<input type="checkbox"/>	Other Washroom	<input type="checkbox"/>

Comment

upgraded thru out - see extras

5. Hardwood Flooring

	Type and Stain		Type and Stain
Main Hall		Upper Landing	
Kitchen / Breakfast	3/4x5" wht oak wirebrush 'Atlantis'	Upper Hall	
Living Room		Master Bedroom	
Dining Room		Bedroom #2	
Family Room		Bedroom #3	
Den/Library		Bedroom #4	
Entrance Vestibule		Bedroom #5	
Lower Landing (If Applicable)		Other Room - Specify	
		thru out standard areas	3/4x5" wht oak wirebrush 'Atlantis'

Comment

"5x30" HERRINGBONE IN KITCHEN/BREAKFAST/SERVERY"

6. Carpeting

	Upgrade	Description
Ground Floor	<input type="checkbox"/>	
Second Floor	<input type="checkbox"/>	
	<input type="checkbox"/>	

Upgrade Underpad	Type	Area
Carpet on Stairs	Capped	Runner - *Upgrade

Comment

7. Fireplace

	Living Room			Family Room			Other Room - Specify		
	Purchased	As Per Plan	N/A	Purchased	As Per Plan	N/A	Purchased	As Per Plan	N/A
Fireplace Type	<input type="radio"/>	<input type="radio"/>	<input type="radio"/>	<input type="radio"/>	<input checked="" type="radio"/>	<input type="radio"/>	<input type="radio"/>	<input type="radio"/>	<input type="radio"/>
Mantle Type	Linear								
Colour / Stain	None								
Surround	N/A								
Hearth	None								

Comment

REVISED: JAN 10 2022

*AS* attached

\*\*\* NOTE: This is not an approved document. Document must be locked \*\*\*

Scheduled Closing Date: Thursday, November 25, 2021

Purchasers: LAURA, GIUSEPPINA PELOSO & ANTHONY, AI Property: 85 of Plan -

Telephone Res. / Bus: (416) 669-8574 / (416) 669-8574

Project: Pine Valley Forevergreen - Phase 1

Decor Advisor: Amanda Ceresino

Model and Elevation: 50.04 C BEAUMONT

8. Trim Carpentry

Interior Doors  Front Door Glass Inserts  Door Handles   
Interior Trim

Comment

9. Plaster Mouldings and Medallions

Standard Throughout  Yes  No  N/A

Entrance Vestibule	<input type="text"/>	<input type="text"/>	Kitchen/Breakfast	<input type="text"/>	<input type="text"/>
Main Hall	<input type="text"/>	<input type="text"/>	Den/Library	<input type="text"/>	<input type="text"/>
Living Room	<input type="text"/>	<input type="text"/>	Lower Landing	<input type="text"/>	<input type="text"/>
Dining Room	<input type="text"/>	<input type="text"/>	Other Room - Specify	<input type="text"/>	<input type="text"/>
Family Room	<input type="text"/>	<input type="text"/>			

Comment

10. Railings and Spindles

Railing Package   
Railing Colour    
Stringer / Riser    
Spindle Colour   
Treads    
Oak Stairs  Yes  No  N/A

Comment

11. Wall Paint / Ceilings

Throughout Finished Areas

Trim Paint

Smooth Ceilings

Ground Floor

Second Floor

Note

Comment

REUSED: JUN 10 2022 *AS JP*

*attached*

\*\*\* NOTE: This is not an approved document. Document must be locked \*\*\*

Scheduled Closing Date: Thursday, November 25, 2021

Purchasers: LAURA, GIUSEPPINA PELOSO & ANTHONY, AI Property: 85 of Plan -

Telephone Res. / Bus: (416) 669-8574 / (416) 669-8574

Project: Pine Valley Forevergreen - Phase 1

Decor Advisor: Amanda Ceresino

Model and Elevation: 50.04 C BEAUMONT

12. Electrical

Hood Fan  White  Stainless  N/A

Above Kitchen Cabinet Light  Yes  No

Below Kitchen Cabinet Light  Yes  No

Standard Appliances

Over The Range Microwave

Chimney Style Fan

Comment

[Empty comment box]

13. Heating and Air Conditioning

Air Conditioning

Gas Provisions Stove

Gas Provisions Dryer

Gas Provisions Barbecue

Comment

[Empty comment box]

14. Additional Comments

[Large empty box for additional comments]

15. Disclaimers and Notes

- 1) Colours of all materials are as close as possible to builder's selection, but not necessarily identical due to variances in manufacturing.
- 2) Any extras listed above are null and void unless accompanied by a separate invoice/amendment. Said invoice must be paid in full.
- 3) The Purchaser acknowledges that after Interior Colour Selection form is signed and dated, no further changes will be permitted other than re-selection due to unavailability. \_\_\_\_\_ Purchaser's Initials
- 4) The Purchaser acknowledges reading and accepting the "Gold Park Homes Decor Centre Disclaimers" form. This document contains other miscellaneous disclaimers.

This Interior Colour Selection is final and approved by:

Signature: attached Date: \_\_\_\_\_

REUSED: JAN 16 2022 [Signature]



### PV - 85 Cabinetry Schedule

ROOM	DESCRIPTION	PRICE	QTY	TOTAL
POWDER ROOM	CONVERT STANDARD VANITY TO FLOATING VANITY <i>NOTE: NO PANEL PURCHASED TO COVER PLUMING, MAY HAVE PIPES EXPOSED</i> <i>NOTE: NO HARDWARE / NO HOLES</i>		1	
KITCHEN	ADJUST CABINERY FOR 36" RANGE (N/C) LEAVE 42" SPACE IN UPPER CABINETS ABOVE RANGE (N/C) <i>NOTE: NO HARDWARE / NO HOLES</i> <i>NOTE: PURCHASERS HAVE REMOVED THE BULKHEAD AND HAVE NOT PURCHASED ANY ADDITIONAL CABINERY, THERE WILL BE A GAP TO THE CEILING</i>	-	1	
		-	1	
<b>CABINERY TOTAL:</b>				

\*\*\*HANDLE PLACEMENT: AT INSTALLERS DISCRETION\*\*\*

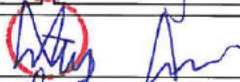
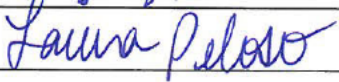
LOT #: PV-85	DATE: May 4, 2021
SIGNATURE: 	
SIGNATURE: 	



SCHEDULE 'F'

PV-85 (attached)

March 15, 2021

PV-85 (attached)

April 13, 2021

PV-85 ~~(attached)~~  
May 3, 2021

# The Beaumont

## 50' SERIES

Elevation A • 4,170 sq.ft.  
4,315 sq.ft. Opt. Elevator  
Elevation B • 4,165 sq.ft.  
4,315 sq.ft. Opt. Elevator  
Elevation C • 4,250 sq.ft.  
4,400 sq.ft. Opt. Elevator

LEGEND:

- ⓐ - EXTERIOR CAT6 LOCATE APPROX 10-12' ABOVE GRADE.
- ⓑ - SPEAKER WIRE
- ⓐ - GFI

GAS R/I BBQ  
YES!  
DELETE BULKHEAD IN KITCHEN

8" DUCT  
HARDWOOD IN KITCHEN/BREAKFAST

HERRINGBONE  
APPROX SCENCE HEIGHT 78" A.F.F.

APPROX SCENCE HEIGHT 78" A.F.F.  
DELETE STD OPENINGS  
INSTALL FULL WALL

ONE STANDARD + ONE ADDITIONAL

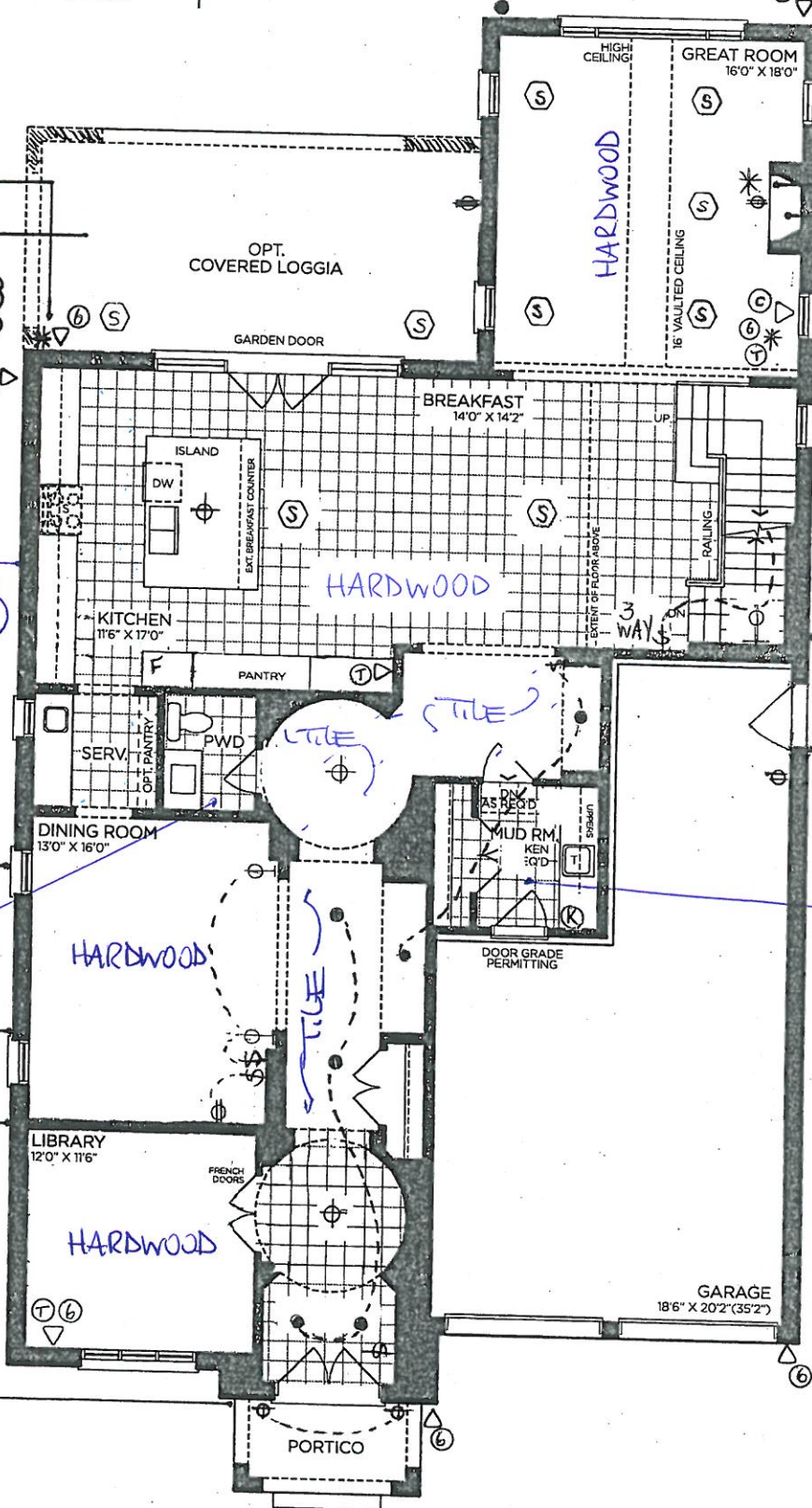

GROUND FLOOR | ELEV. A

VENDOR

PURCHASER

PURCHASER

**GOLDPARK**  
WORTH MORE™

Prices, figures, illustrations, sizes, features and finishes are subject to change without notice. Areas and dimensions are approximate and actual usable floor space may vary from the stated area. Layout may be reverse of the unit purchased. E. & O.E. 5004



SCHEDULE 'F'



PV-85 attached  
 March 15, 2021  
 PV-85 attached  
 April 13, 2021  
 PV-85 ~~attached~~  
 May 3, 2021

# The Beaumont

**50' SERIES**  
 Elevation A • 4,170 sq.ft.  
 4,315 sq.ft. Opt. Elevator  
 Elevation B • 4,165 sq.ft.  
 4,315 sq.ft. Opt. Elevator  
 Elevation C • 4,250 sq.ft.  
 4,400 sq.ft. Opt. Elevator

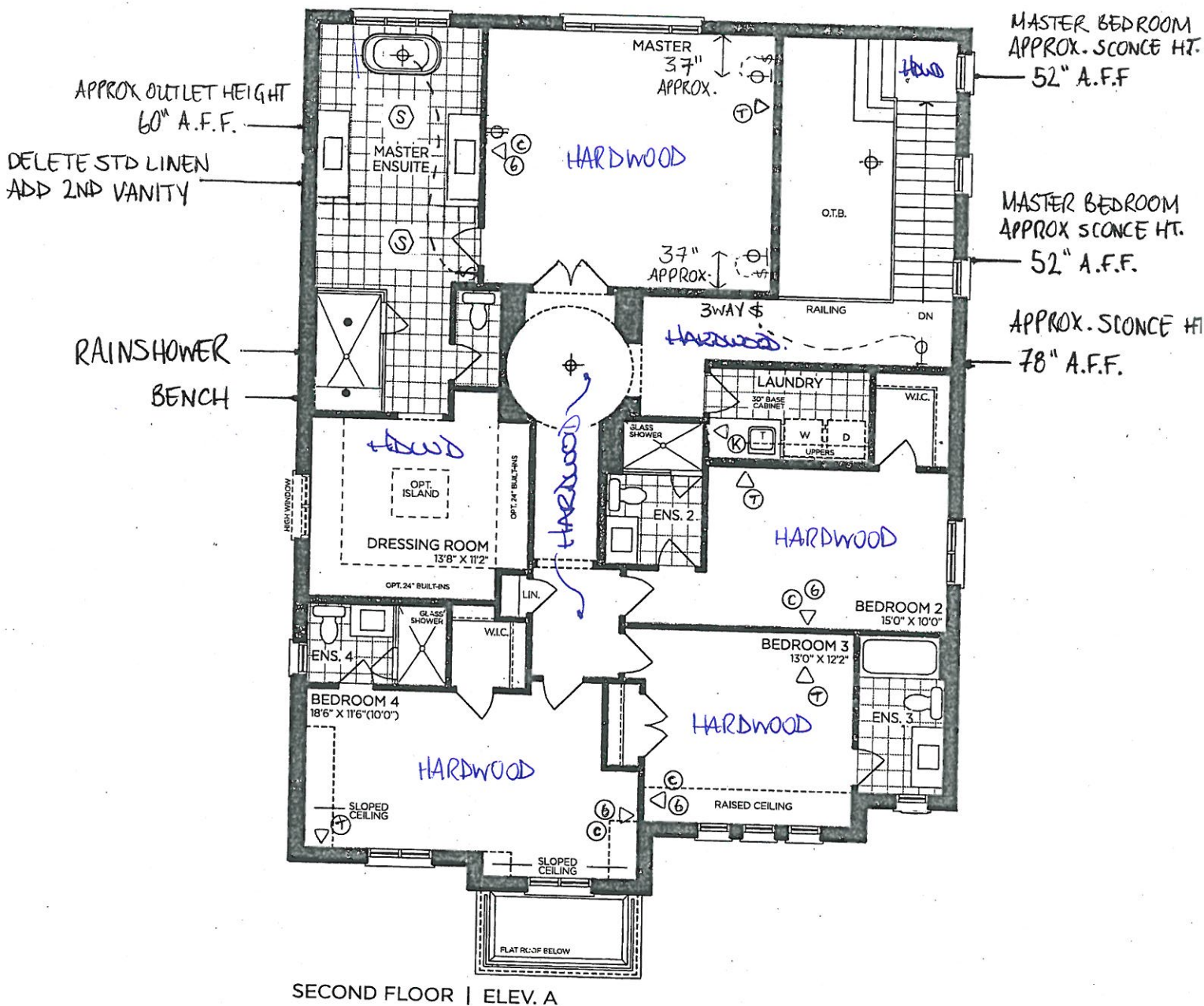

VENDOR

PURCHASER

PURCHASER

**GOLDPARK**  
 WORTH MORE™

Prices, figures, illustrations, sizes, features and finishes are subject to change without notice. Areas and dimensions are approximate and actual usable floor space may vary from the stated area. Layout may be reverse of the unit purchased. E. & O.E. 5004

SCHEDULE 'F'



PV-85 *attached*  
 April 13, 2021  
 PV-85 *AP*  
 May 3, 2021

# The Beaumont

## 50' SERIES

Elevation A • 4,170 sq.ft.  
 4,315 sq.ft. Opt. Elevator  
 Elevation B • 4,165 sq.ft.  
 4,315 sq.ft. Opt. Elevator  
 Elevation C • 4,250 sq.ft.  
 4,400 sq.ft. Opt. Elevator

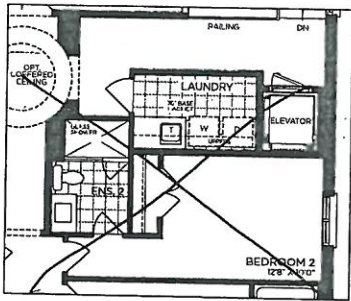

OPT. PART. SECOND FLOOR | ELEV. A (ELEVATOR)

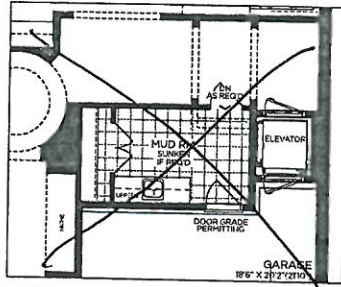

OPT. GROUND FLOOR | ELEV. A (ELEVATOR)

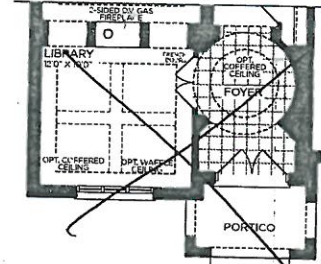

PART. OPT. LIBRARY GROUND FLOOR | ELEV. A, B & C

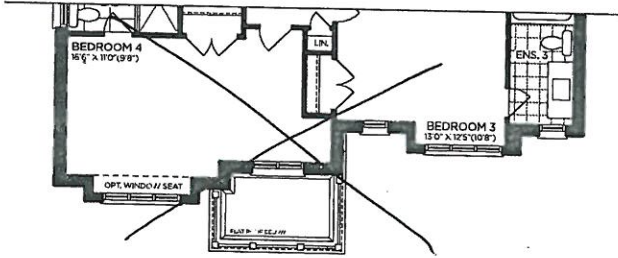

PART. OPT. SECOND FLOOR | ELEV. B 5 BEDROOM

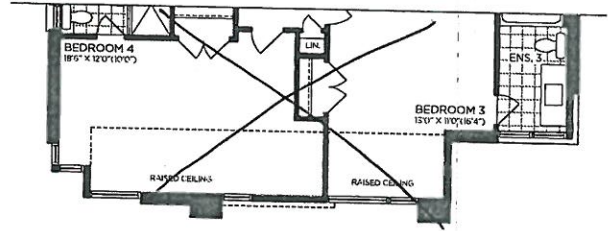

PART. OPT. SECOND FLOOR | ELEV. C 5 BEDROOM

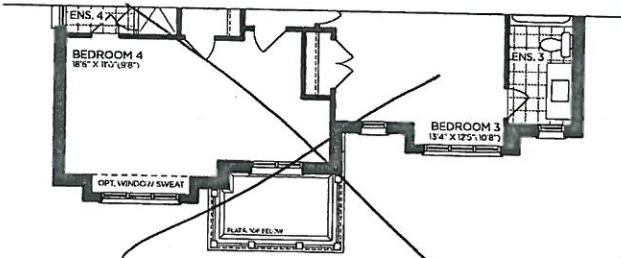

PART. SECOND FLOOR | ELEV. B

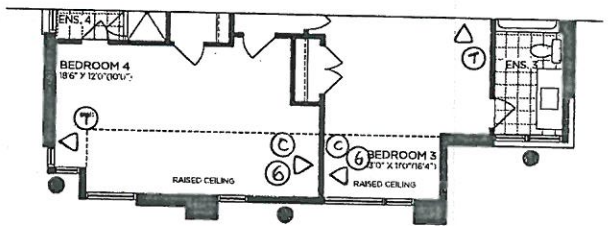

PART. SECOND FLOOR | ELEV. C

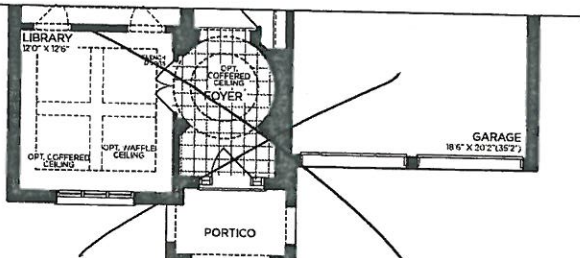

PART. GROUND FLOOR | ELEV. B

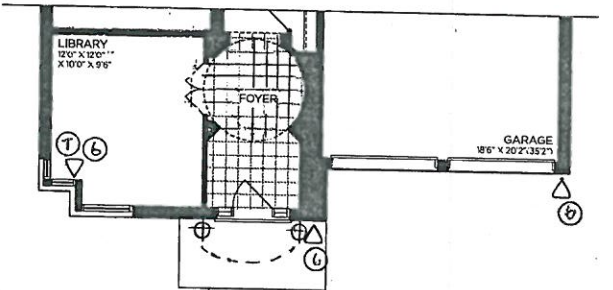

PART. GROUND FLOOR | ELEV. C

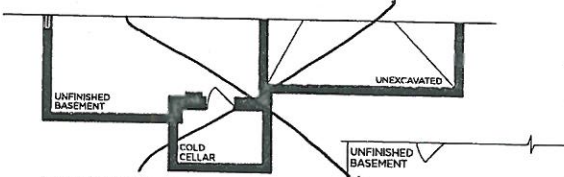

PART. BASEMENT | ELEV. B

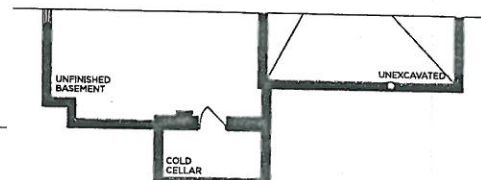

PART. BASEMENT | ELEV. C

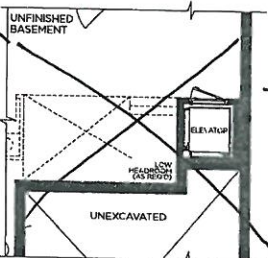

OPT. BASEMENT | ELEV. A (ELEVATOR)

VENDOR   
 PURCHASER   
 PURCHASER

**GOLDPARK**  
 WORTH MORE™

Prices, figures, illustrations, sizes, features and finishes are subject to change without notice. Areas and dimensions are approximate and actual usable floor space may vary from the stated area. Layout may be reverse of the unit purchased. E. & O.E. 5004



SCHEDULE 'F'

PV-85 attached  
March 15, 2021

PV-85 attached  
April 13, 2021

~~PV-85~~ ~~PP~~  
May 3, 2021

# The Beaumont

## 50' SERIES

Elevation A • 4,170 sq.ft.  
4,315 sq.ft. Opt. Elevator  
Elevation B • 4,165 sq.ft.  
4,315 sq.ft. Opt. Elevator  
Elevation C • 4,250 sq.ft.  
4,400 sq.ft. Opt. Elevator

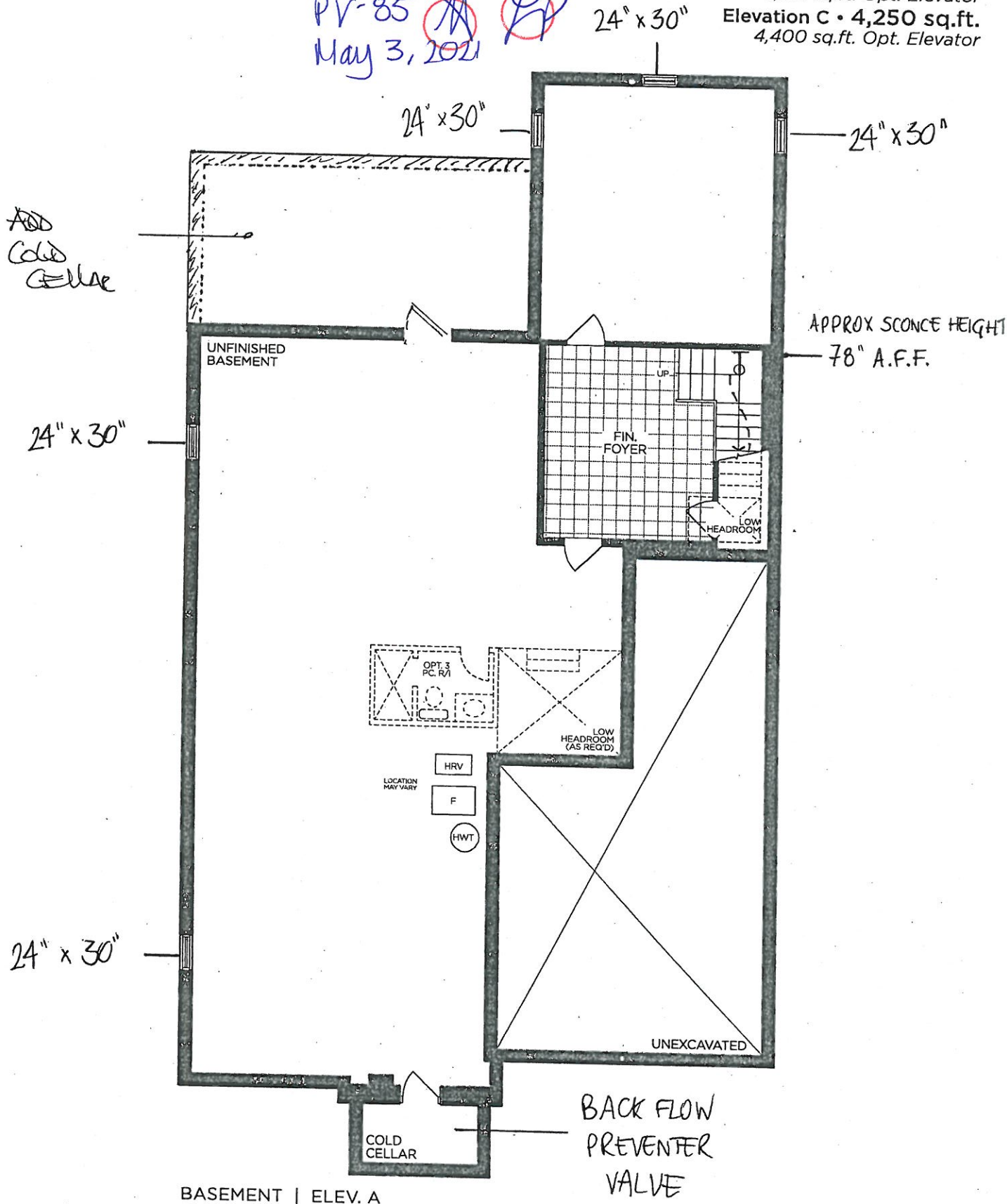

VENDOR

PURCHASER

PURCHASER

**GOLDPARK**  
WORTH MORE™

Prices, figures, illustrations, sizes, features and finishes are subject to change without notice. Areas and dimensions are approximate and actual usable floor space may vary from the stated area. Layout may be reverse of the unit purchased. E. & O.E. 5004

AV-85

May 3, 2021

**GOLDPARK HOMES  
PINE VALLEY  
VAUGHAN, ONTARIO  
MODEL: (5004) BEAUMONT**

SITE STANDARD: WHITE 3/4" EXTENSION  
SOFT-CLOSE DRAWERS & SOFT-CLOSE  
HINGES TO KITCHEN AREA  
  
10' CEILING - 12" H COFFERED CEILING -  
M.H. = 102" + 3/4" H CONTEMPORARY  
MOLDING + 5 1/4" H FURRING RAIL  
+ LARGE CORNICE MOLDING TO  
UNDERSIDE OF BOX

\* GAP ABOVE CABINETS

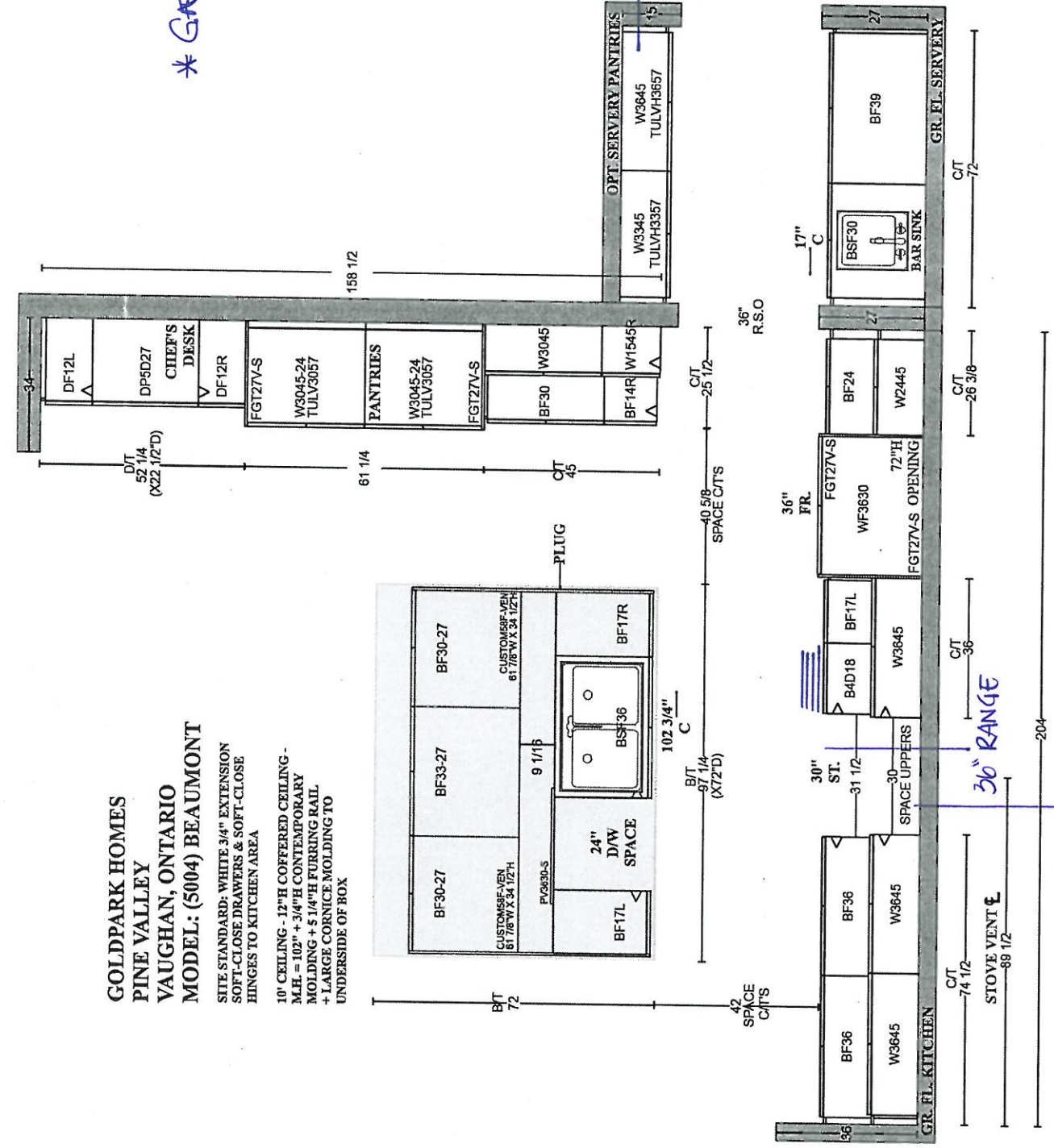

No!



PLAN VIEW

AV-95  

May 3, 2021

**GOLDPARK HOMES  
 PINE VALLEY  
 VAUGHAN, ONTARIO  
 MODEL: (5004) BEAUMONT**

SITE STANDARD: WHITE 3/4" EXTENSION  
 SOFT-CLOSE DRAWERS & STANDARD SLAM DOOR HINGES  
 TO VANITIES

ONE TOP DRAWER WHERE POSSIBLE THROUGHOUT EACH  
 VANITY, ONE BANK OF DRAWERS WHERE POSSIBLE  
 THROUGHOUT EACH MASTER ENSUITE VANITY

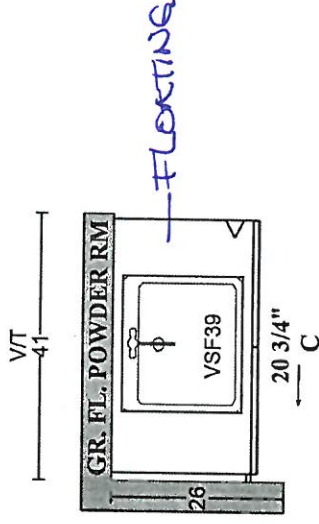
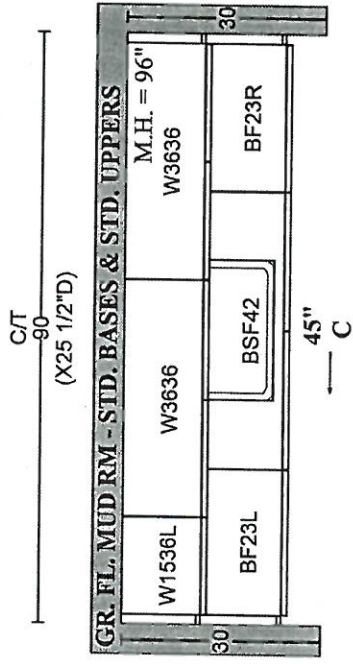

*FLOTTING*

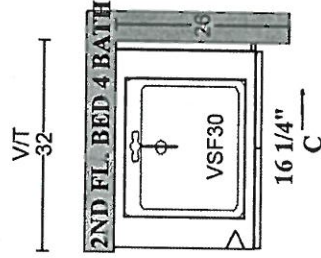
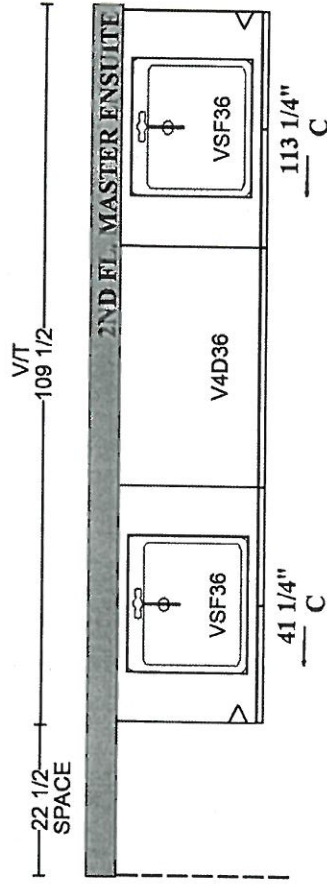
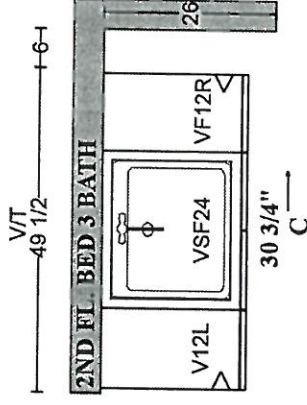
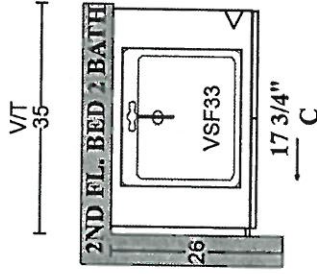
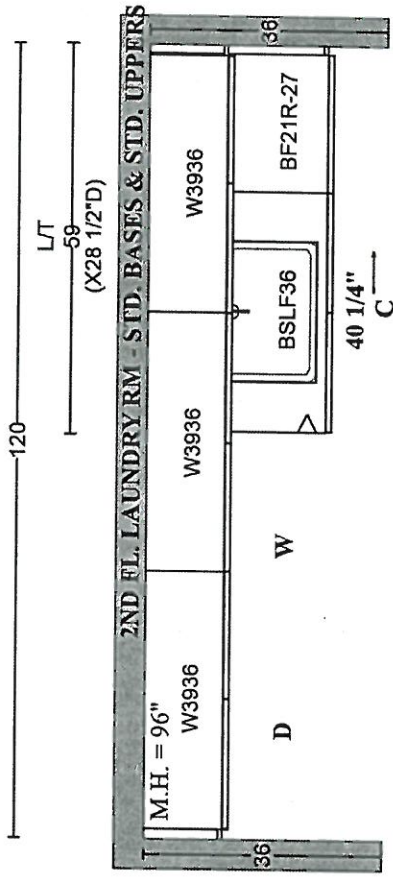

PLAN VIEW



PINE VALLEY  
FOREVERGREEN

STONE COUNTERTOP EDGE PROFILES



STANDARD 2CM EASED EDGE



LOCATION:

THRU OUT

\_\_\_\_\_  
\_\_\_\_\_  
\_\_\_\_\_  
\_\_\_\_\_

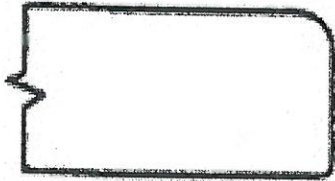

UPGRADE 3CM EASED EDGE

LOCATION:

\_\_\_\_\_  
\_\_\_\_\_  
\_\_\_\_\_  
\_\_\_\_\_

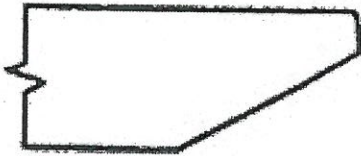

UPGRADE 4CM MITRED EDGE

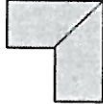

LOCATION:

\_\_\_\_\_  
\_\_\_\_\_  
\_\_\_\_\_  
\_\_\_\_\_



UPGRADE 2CM OGEE EDGE

LOCATION:

\_\_\_\_\_  
\_\_\_\_\_  
\_\_\_\_\_  
\_\_\_\_\_

LOT #: PV-85

DATE: May 3, 2021

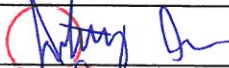
SIGNATURE: 

SIGNATURE: 



STANDARD HARDWARE / HANDLES



H001-02



H001-03



H001-04



H009-03



H009-09



H011-03



H011-05



H011-06

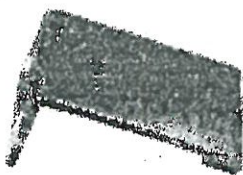

H033-01



H039-03  
→ Laundry Room

\*NO HARDWARE  
→ Kitchen  
→ Powder Room

LOT # PV-85

DATE: May 3, 2021

SIGNATURE: *May 3*

SIGNATURE: *Relaxo*



STANDARD HARDWARE / KNOBS



K002-02



K002-03



K002-04



K002-06



K002-05

- ▶ Mud Room
- ▶ Master Ensuite
- ▶ Ensuite 2
- ▶ Ensuite 3
- ▶ Ensuite 4



K008-14



K024-03

\*NO HARDWARE

\*TOUCH-LATCH

LOT # PV-85

DATE: May 3, 2021

SIGNATURE:

SIGNATURE:





PINE VALLEY

FOREVERGREEN

### EMERY

#### RECTANGULAR UNDERMOUNT SINK

- 4220CGY Undermount Sink, Soft White
- 4220CGY-077 Undermount Sink, Matte Black
- 4220CGY-088 Undermount Sink, Slate Grey

#### PRODUCT SPECS:

- Vitreous china
- Front overflow hole
- 8 1/4" Bowl depth
- Template and mounting hardware supplied

#### COMPLIANCE CERTIFICATIONS

- Meets or exceeds the following:
- IAPMO cUPC
  - ASME A112.19.2 / CSA B45.1

#### SHIPPING

Cube 1.85  
 GW 20 lbs

#### DIMENSIONS:

##### Outer:

545mm W x 355mm D x 210mm H  
 21 1/2" W x 14" D x 8 1/4" H

##### Inner:

495mm W x 305mm D x 160mm H  
 19 1/2" W x 12" D x 6 1/4" H

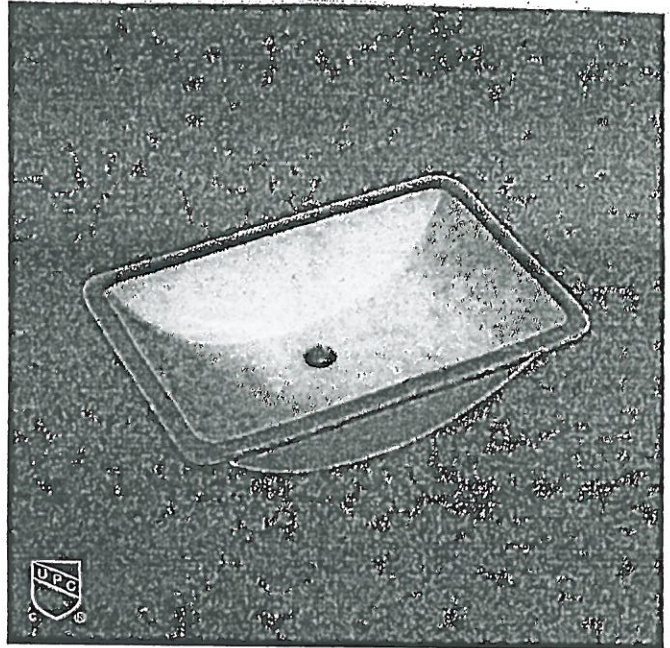

**TO BE SPECIFIED**

Colour:

- Soft White
- Matte Black
- Slate Grey

**NOTES:** Dimensions of fixtures are nominal and may vary within the range of tolerances established by ASME standard A112.19.2. These measurements are subject to change or cancellation. No responsibility is assumed for use of superseded or voided pages.

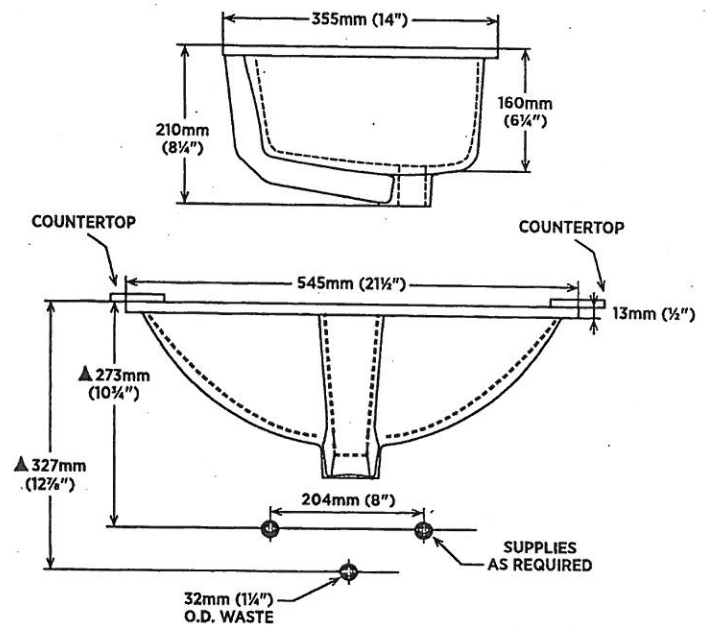
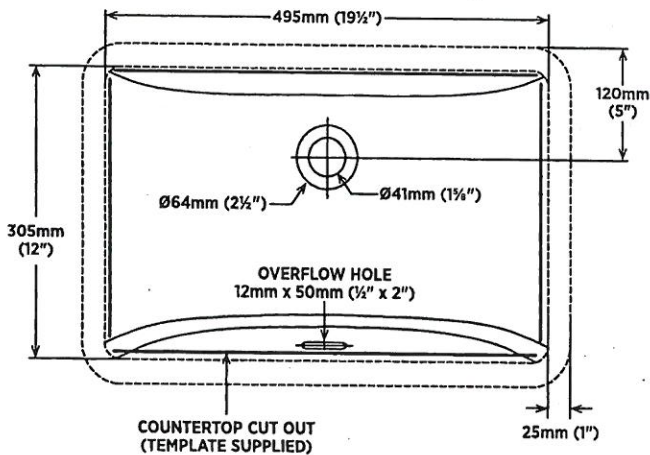

Lot# *PV-85*

Room: *Powder Room*

Signature: *[Signature]*

Date: *May 4, 2021*

Signature: *Laura Peloso*



UPGRADE SHOWER HARDWARE

SQ6X6

Shower Door Handle + Hinges

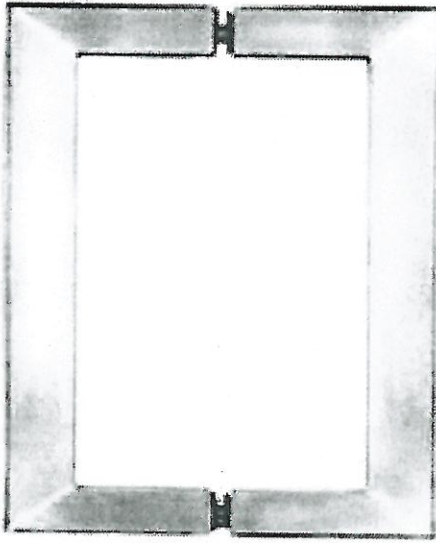

SQ6X6  
Shower Door Handle

6" x 6" back-to-back  
3/4" square tube  
(Also available single sided)

CHROME

MATTE BLACK

BRUSHED GOLD

Lot# PV-35	Date: May 4, 2021	Room: Master Ensuite
Signature: 		
Signature: 		



UPGRADE SHOWER HARDWARE

SQ6X6

Shower Door Handle + Hinges

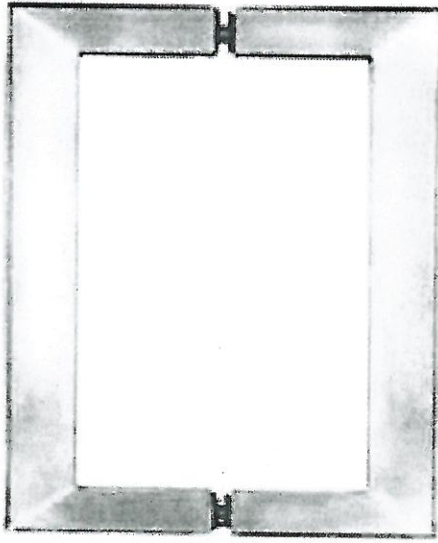

SQ6X6  
Shower Door Handle

6" x 6" back-to-back  
3/4" square tube  
(Also available single sided)

- CHROME
- MATTE BLACK

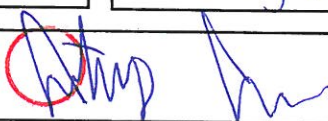
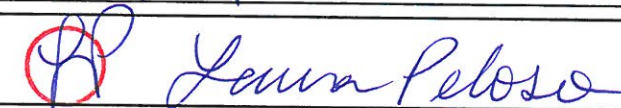
Lot# PV-95	Date: May 4, 2021	Room: Ensuite 2, Ensuite 4
Signature: 		
Signature: 		



# BATHROOM ACCESSORIES

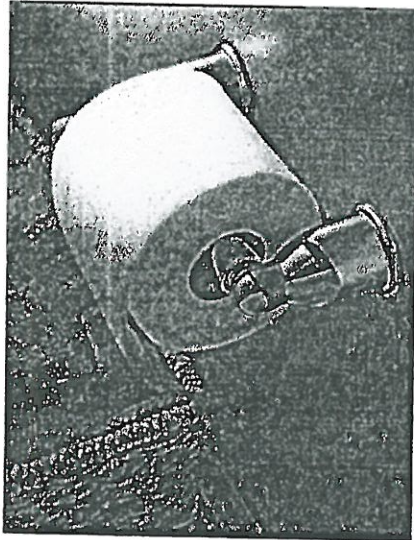

Tissue Holder  
Mason - Chrome

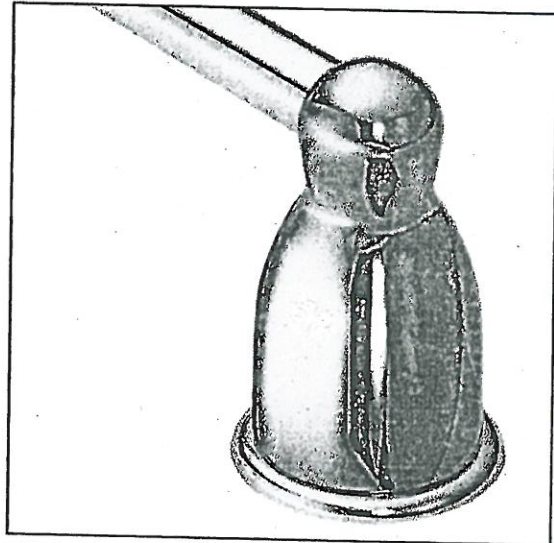

Towel Bar  
Mason - Chrome

**Please select one of the following:**

- INSTALL STANDARD BATHROOM ACCESSORIES THRU OUT  
(tissue holder + towel bar) *\*location as per vendors discretion\**
- \*DO NOT\*** INSTALL STANDARD BATHROOM ACCESSORIES  
THRU OUT *\*tissue holder + towel bar will not be provided\**

LOT # PV-85

DATE: May 3, 2021

SIGNATURE:

SIGNATURE:



Project: Pine Valley

Lot: 85

Purchaser(s): Laura Peloso & Anthony Arci

Standard Hood Fan Deletion

We acknowledge that the builder's standard hood fan will not be installed.  
Do not supply, install and/or credit. We will install our own hood fan after closing.

Signature: 

Signature: 

Date: May 3, 2021



PLUMBING UPGRADES

MOEN - ALIGN

Posi-Temp SHOWER ONLY\* with 3 Function Transfer Valve/Trim and Slide Bar with Handshower

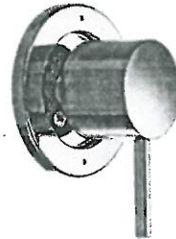

- CHROME
- BRUSHED NICKEL (BN)
- BRUSHED GOLD (BG)
- MATTE BLACK (BL)

\*from CEILING

MODEL: T2192EP / U361CI / UT4191 / 62320 / 3887EP / A725 / 226651

Lot# PV-85

Date: April 13, 2021

Room: Master Ensuite

Signature: attached

Signature: attached



EXTERIOR LED SOFFIT POT LIGHTS

---

5004 BEAUMONT – ELEVATION C

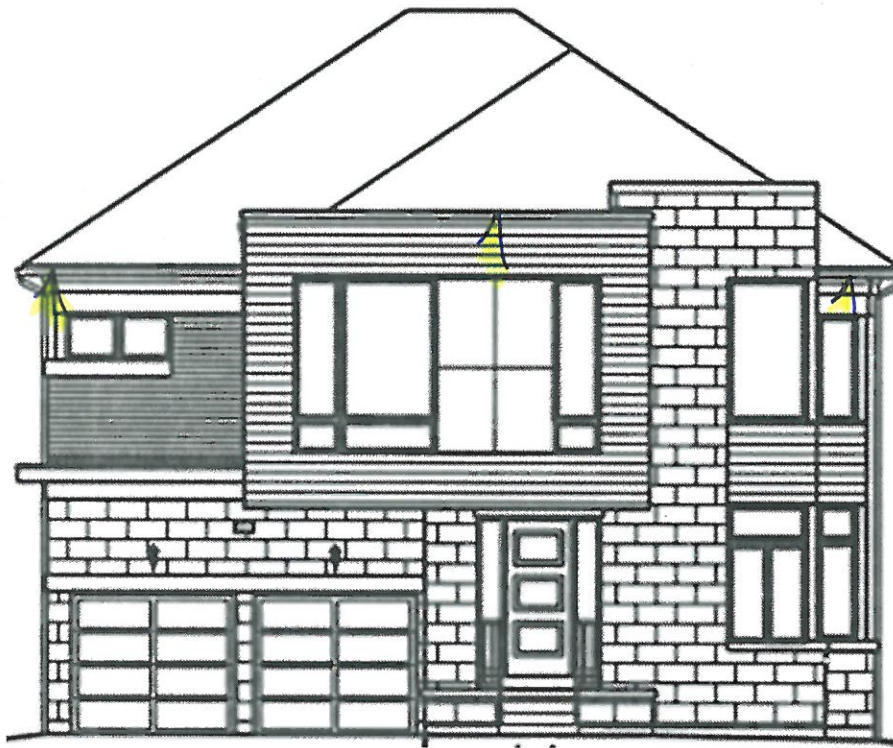

---

LOT #: PV-85	DATE: April 13, 2021
SIGNATURE: attached	
SIGNATURE: attached	

EXTERIOR LED SOFFIT POT LIGHTS

5004 BEAUMONT – ELEVATION C



LOT#: PV-85	DATE: April 13, 2021
SIGNATURE: <i>Gaura Patel</i>	
SIGNATURE: <i>Steve D.</i>	



PLUMBING UPGRADES



MOEN - ALIGN

Posi-Temp SHOWER ONLY\* with 3 Function Transfer Valve/Trim and Slide Bar with Handshower

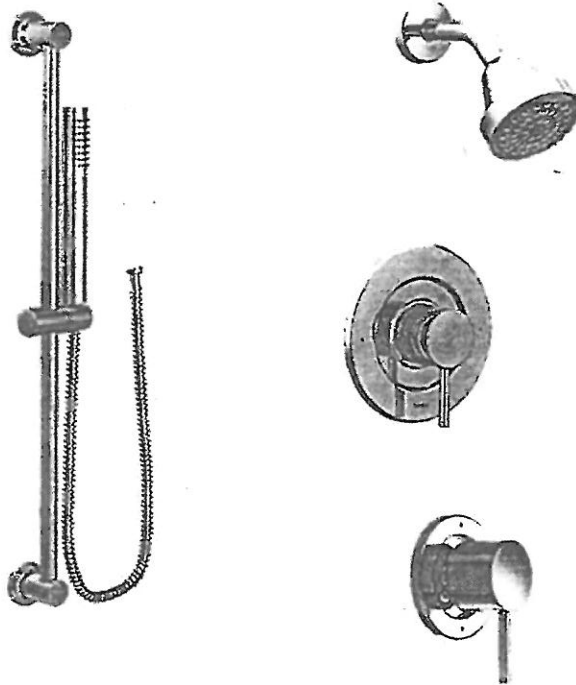

- CHROME
- BRUSHED NICKEL (BN)
- BRUSHED GOLD (BG)
- MATTE BLACK (BL)

\*from CEILING

MODEL: T2192EP / U361CI / UT4191 / 62320 / 3887EP / A725 / 226651

Lot# PV-85	Date: April 13, 2021	Room: Master Ensuite
Signature: <i>Jason Peloso</i>		
Signature: <i>[Signature]</i>		

PV-85   
 March 22, 2021

**PRG366WH**  
**36-INCH GAS PRO HARMONY® RANGE**  
 PROFESSIONAL SERIES, STANDARD-DEPTH, PORCELAIN COOKTOP SURFACE



**FEATURES & BENEFITS**

- ★ - The Star® Burner delivers superior flame spread for more even heating
- ★ - ExtraLow® feature provides a wide range of temperature control, perfect for simmering delicate sauces
- ★ - 2 ExtraLow® burners for simmering, melting, or holding long durations
  - Raised pedestal burner and porcelain maintop for effortless cleaning
  - Convection Bake offers precise multi-level baking results

**TECHNICAL DETAILS**

Circuit Breaker	15 A
Volts	120 V, 60Hz
Energy Source	Gas
Plug Type USA	120V – 3 Prong
Power Cord Length	65" (1,651mm)
Gas Supply	3/4"

**WARRANTY**

Limited Warranty, Entire Appliance, Parts and Labor	2 Year
---	--------

SEE PAGE 2 FOR INCLUDED AND OPTIONAL ACCESSORIES

**RANGETOP**

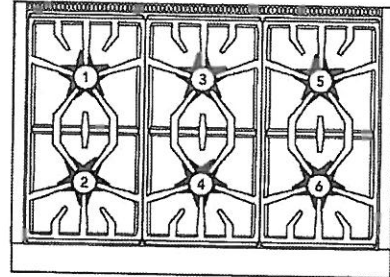

Total number of cooktop Burners	6
1 – Power of Back Left Burner BTU	15,000 and XLO
2 – Power of Front Left Burner BTU	18,000 and XLO
3 – Power of Back Center Burner BTU	15,000
4 – Power of Front Center Burner BTU	18,000
5 – Power of Back Right Burner BTU	15,000
6 – Power of Front Right Burner BTU	18,000

**OVEN**

Oven Capacity	5.1 cu. ft.
Cooking Modes	Bake, Convection Bake, Roast, Broil
Sabbath	Yes
Self Clean	No
Telescopic Rack(s)	3
Interior Lights	2
Bake Power	20,500 BTU
Broil Power	17,500 BTU
Home Connect™ (Wi-Fi Enabled)	Yes
Cavity Interior Dimensions (HxWxD)	16 3/8" x 29 1/8" x 18 5/8"
Cavity Usable Dimensions (HxWxD)	11 1/4" x 25 5/8" x 16 3/4"
<b>DIMENSIONS &amp; WEIGHT</b>	
Overall Appliance Dimensions (HxWxD)	35 3/4" – 36 3/4" x 35 15/16" x 24 5/8"
Required Cutout Size (HxWxD)	35 3/4" – 36 3/4" x 36" x 24"
Net Weight	415 lbs.

★ THERMADOR® EXCLUSIVE

PV-85   
 March 22, 2021

**PRG366WH**  
**36-INCH GAS PRO HARMONY® RANGE**  
 PROFESSIONAL SERIES, STANDARD-DEPTH, PORCELAIN COOKTOP SURFACE



**36-INCH RANGE DIMENSIONS**

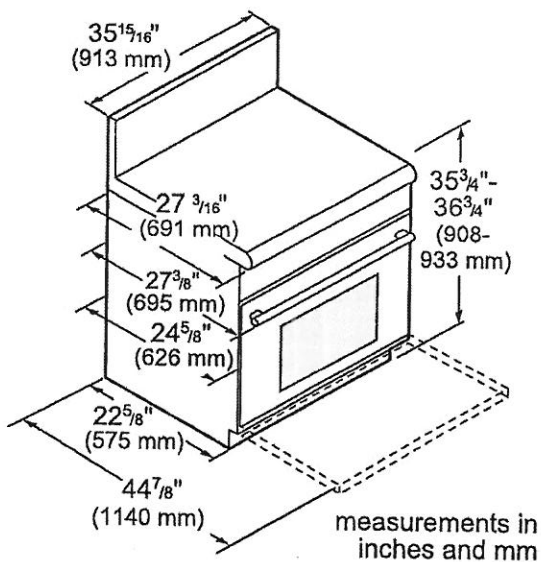

**36-INCH RANGE CUTOUT DIMENSIONS**

measurements in inches (mm)

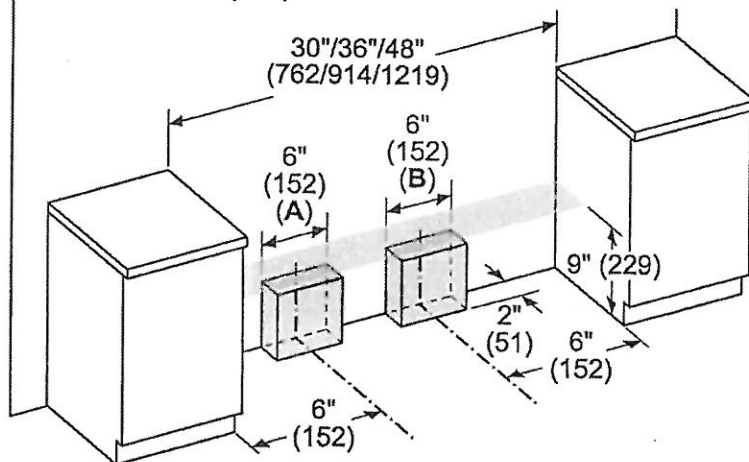

A: Gas zone  
 B: Electric zone

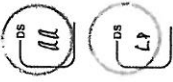
PV-85   
 March 22, 2021

**PRG366WH**  
**36-INCH GAS PRO HARMONY® RANGE**  
 PROFESSIONAL SERIES, STANDARD-DEPTH, PORCELAIN COOKTOP SURFACE



**36-INCH RANGE DIMENSIONS AND CLEARANCE REQUIREMENTS WITH "LOW BACK"**

**NOTE:** A 36-inch minimum clearance is required between the top of the cooking surface and the bottom of an unprotected cabinet. A 30-inch clearance can be used when the bottom of the wood or metal cabinet is protected by not less than 1/4 inch of a flame retardant material covered with not less than No. 28 MSG sheet steel, 0.015 inch (0.4 mm) thick stainless steel, 0.024 inch (0.6 mm) aluminum, or 0.020 inch (0.5 mm) thick copper.

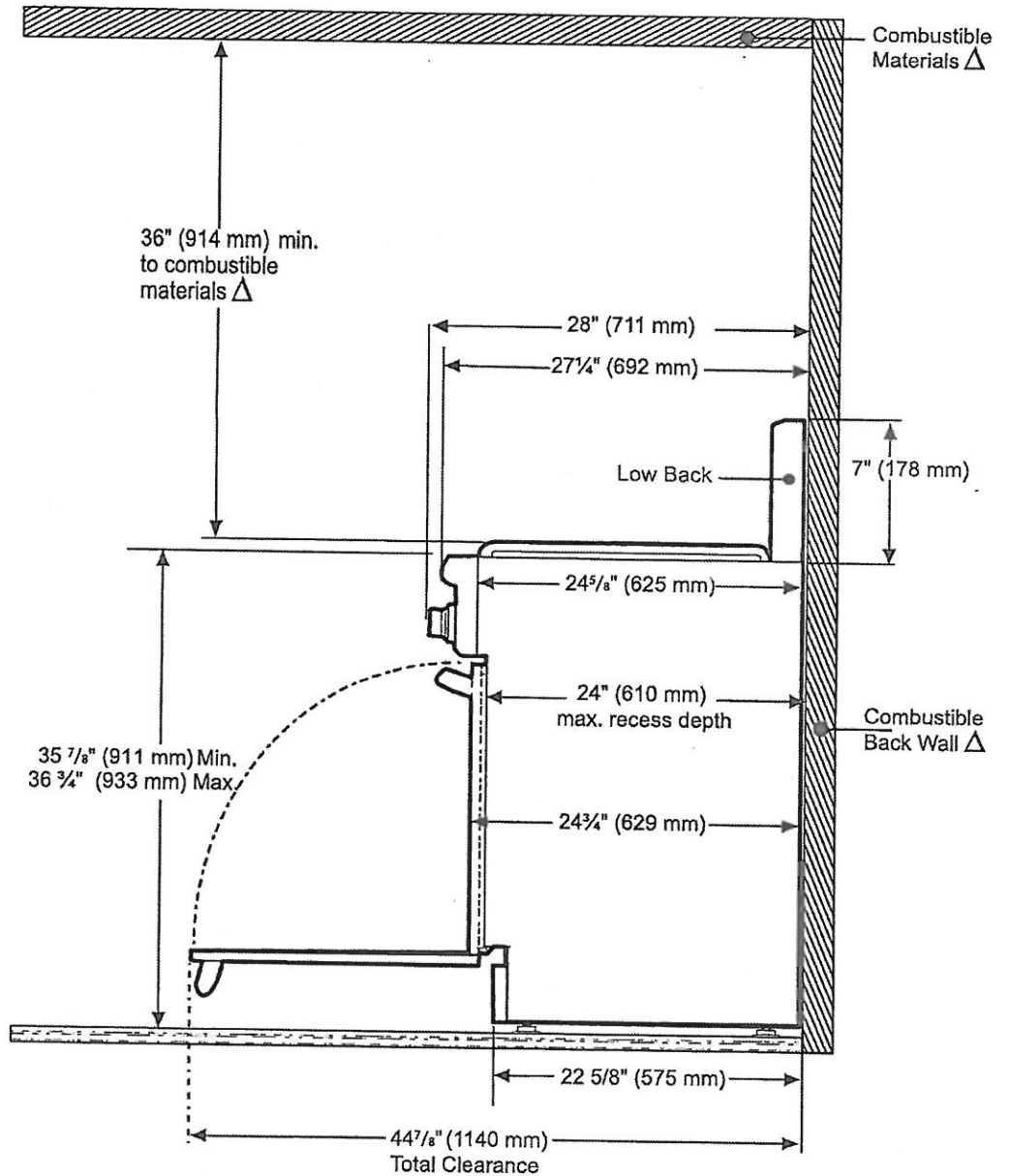

$\Delta$  As defined in the "National Fuel Gas Code" (ANSI Z223.1, Current Edition). Clearances from non-combustible materials are not part of the ANSI Z21.1 scope and are not certified by CSA. Clearances of less than 6" (152 mm) must be approved by the local codes and/or by the local authority having jurisdiction.

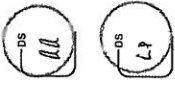
PV-85   
 March 22, 2021

**PRG366WH**  
**36-INCH GAS PRO HARMONY® RANGE**  
 PROFESSIONAL SERIES, STANDARD-DEPTH, PORCELAIN COOKTOP SURFACE



**36-INCH RANGE DIMENSIONS AND CLEARANCE REQUIREMENTS WITH "FLUSH ISLAND TRIM"**

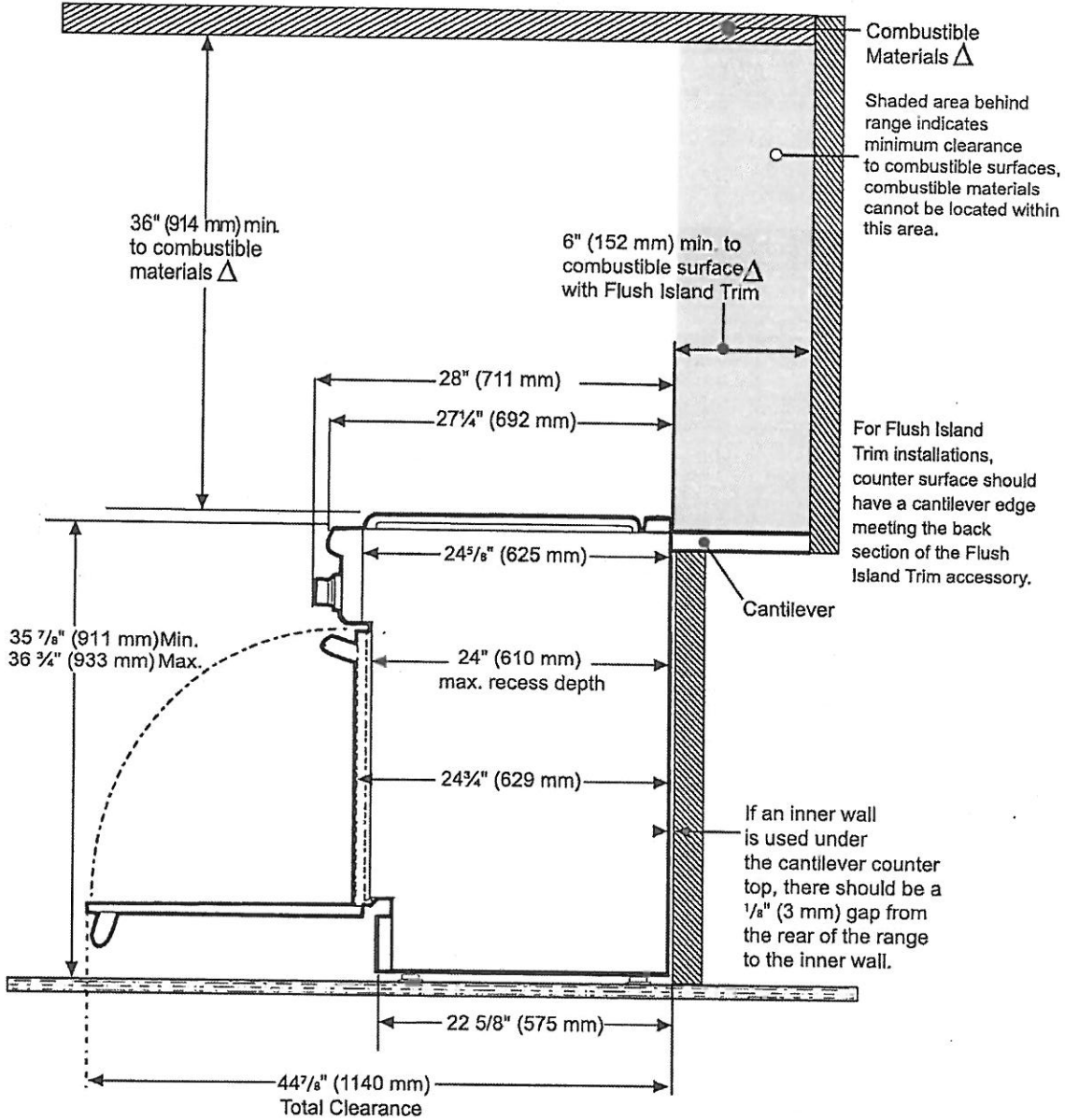

△ As defined in the "National Fuel Gas Code" (ANSI Z223.1, Current Edition). Clearances from non-combustible materials are not part of the ANSI Z21.1 scope and are not certified by CSA. Clearances of less than 6" (152 mm) must be approved by the local codes and/or by the local authority having jurisdiction.

These warranties give you specific legal rights and you may have other rights that vary from state to state. Limited warranty from date of purchase. For complete warranty details, refer to your Use & Care manual, or ask your dealer.

Specifications are for planning purposes only. Refer to installation instructions and consult your countertop supplier prior to making counter opening. Consult with a heating and ventilation engineer for your specific ventilation requirements. For the most detailed information, refer to installation instructions accompanying product or write to Thermador indicating the model number. Specifications are correct at time of printing. Thermador reserves the right to change product specifications or design without notice. Some models are certified for use in Canada. Thermador is not responsible for products that are transported from the U.S. for use in Canada.

1 800 735 4328 | USA THERMADOR.COM | CANADA THERMADOR.CA | ©2020 BSH HOME APPLIANCES CORPORATION. ALL RIGHTS RESERVED.

PV-85   
 March 22, 2021

**DWHD650WFP**  
**EMERALD® 6-PROGRAM DISHWASHER**  
 PROFESSIONAL SERIES HANDLE

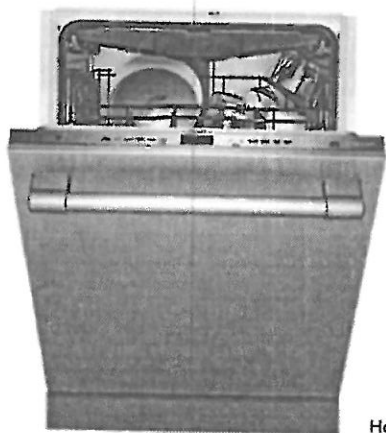

HomeConnect

Also Available In:  
 DWHD650WFM – Flat Stainless Steel Panel with  
 Masterpiece® Series Handle  
 DWHD650WPR – Custom Panel

**FEATURES & BENEFITS**

- Chef's Tool Drawer (3rd Rack) is designed to make loading and unloading tools and hard to place items extraordinarily easier
- Sens-A-Wash® measures water cleanliness and adjusts wash cycle
- Three stage advanced filtration recirculates water for sparkling results
- 3-Level adjustable upper rack is customizable for all of your needs, designed to be raised for extra large items placed on the bottom rack, or lowered to fit taller wine glasses on the upper rack
- Extra Dry Option adds extra heat to the final rinse to enhance drying results
- Impressively Quiet®—48 dBA for peaceful kitchen experience
- Thermador Connected Experience by Home Connect brings exclusive dish features that keep you connected. Always.

**ACCESSORIES (OPTIONAL)**

Dishwasher Supply and Drainage Hose Extension 76 3/4"	SGZ1010UC
Dishwasher Accessory Kit	SMZ5000
Fine Silverware Carafe	SMZ5002UC
Junction Box	SMZPCJB1UC

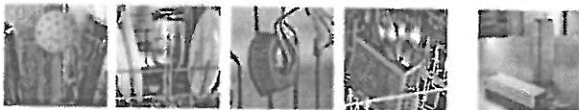

Accessory Kit includes Extra-Tall-Item Sprinkler, Vase / Bottle Holder, 3 Plastic Item Clips and Small Item Basket

Fine Silverware Carafe

**GENERAL PROPERTIES**

Number Of Wash Cycles	6
Number Of Options	5
dBA	48
Third Rack	Chef's Tool Drawer®
Rack Adjustability	Rackmatic 3-Stage
Tub Material	Stainless Steel
Control Type	Touch Control
Concealed Water Heating Element	Yes
Leak Protection System	24/7 AquaStop®
Water Softener	No
Five-Level Wash	Yes
Childlock	No
Home Connect (Wi-Fi Enabled)	Yes

**EFFICIENCY**

Water Usage Per Cycle (g)	3.5 g
Energy Efficiency Class	Tier 1
ENERGY STAR® Certified	Yes
Total Annual Energy Consumption (kWh)	269 kWh
Total Annual Water Consumption (g)	624 g

**CAPACITY**

Number Of Place Settings	16
--------------------------	----

**TECHNICAL DETAILS**

Watts (W)	1,440 W
Current (A)	12 A
Volts (V)	120 V
Frequency (Hz)	60 Hz
Power Cord Length (in)	67"
Power Cord Install Length from Corner of Unit when Facing the Door (in)*	Left - 45" Right - 56"
Minimum Water Pressure (lb/sin)	14
Max. Temperature for Water Intake	140° F
Length Inlet Hose (in)	N/A
Length Outlet Hose (in)	79"

**DIMENSIONS & WEIGHT**

Overall Appliance Dimensions (HxWxD) (in)	33 7/8" x 23 9/16" x 23 3/4"
Required Cutout Size (HxWxD) (in)	33 7/8" Min. x 23 5/8" Min. x 24"
Adjustable Feet	Yes
Net Weight (lbs)	93 lbs

\*September 2020 running production change to remove adhesive routing clips for power cord. These clips and the edge protector are now included in the dishwasher accessory kit #SMZEPC1UC.

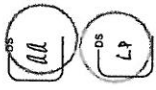
PV-85   
 March 22, 2021

**DWHD650WFP**  
**EMERALD® 6-PROGRAM DISHWASHER**  
 PROFESSIONAL SERIES HANDLE



WARRANTY	
Limited Warranty, Entire Appliance, Parts and Labor	2 Year
Limited Warranty for Microprocessor or Printed Circuit Board; Parts Only	3rd to 5th Year
Limited Warranty for Racks (Does Not Include Rack Components); Parts Only	3rd to 5th Year
Limited Warranty for Rust-through On Inner Tub Liner; Parts Only	Lifetime

**DISHWASHER & CUTOUT DIMENSIONS**

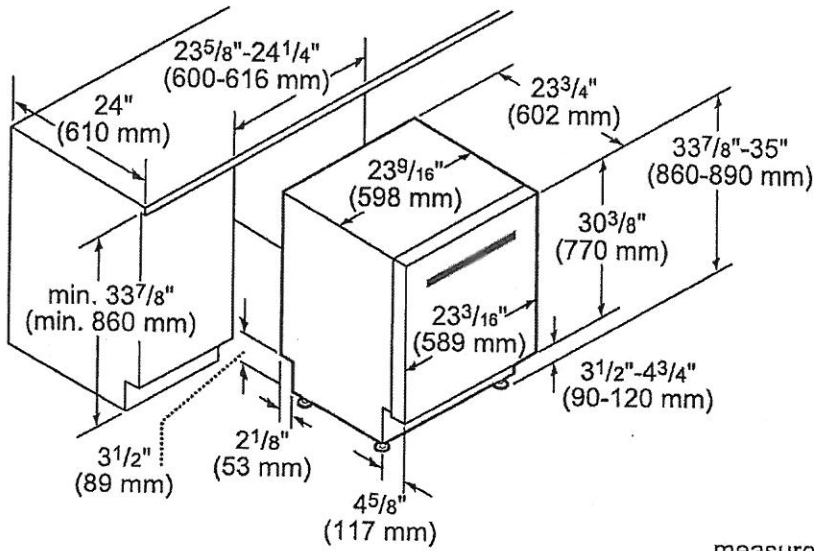

measurements in inches and mm

DocuSign Envelope ID: 6681413F-7A13-4D43-8FF4-319A43F4B349

These warranties give you specific legal rights and you may have other rights that vary from state to state. Full warranty and limited warranty from date of installation. For complete warranty details, refer to your Use & Care manual, or ask your dealer.

Specifications are for planning purposes only. Refer to installation instructions and consult your countertop supplier prior to making counter opening. Consult with a heating and ventilation engineer for your specific ventilation requirements. For the most detailed information, refer to installation instructions accompanying product or write to Thermador indicating the model number. Specifications are correct at time of printing. Thermador reserves the right to change product specifications or design without notice. Some models are certified for use in Canada. Thermador is not responsible for products that are transported from the U.S. for use in Canada.

1 800 735 4328 | USA THERMADOR.COM | CANADA THERMADOR.CA | ©2020 BSH HOME APPLIANCES CORPORATION. ALL RIGHTS RESERVED.

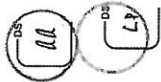
PV-85   
 March 22, 2021

**T30IF905SP**  
**30-INCH BUILT-IN FREEZER COLUMN WITH**  
**INTERNAL ICE MAKER**  
 FREEDOM® COLLECTION, PANEL-READY

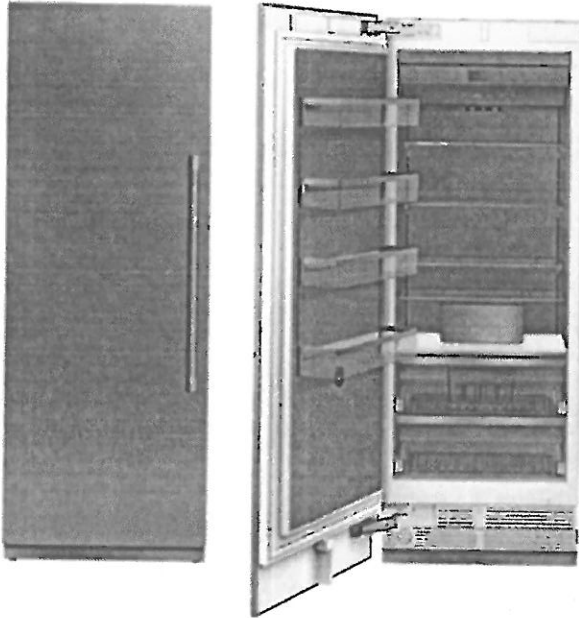

**FEATURES & BENEFITS**

- Full Stainless Steel Inner Liner
- Freedom® Hinge enables true flush design
- Auto Door Opening provides the opening of the door with just a slight push or pull
- SoftClose® Drawers for easy and controlled storage
- Sleek clean design for the perfect symmetry when paired with additional columns
- TFT control panel managing all your columns functions

**TEMPERATURE RANGES**

Freezer	-11°F (-24°C) to 7°F (-14°C)
SuperFreeze®	-22°F (-30°C) for approximately 52 hours
Energy Saving (Economy) Mode	3°F (-16°C)

**GENERAL PROPERTIES**

Home Connect™ (Wi-Fi Enabled)	Yes
Panel Ready	Yes
Reversible Door Swing	Yes
SoftClose® Door	Yes*
SoftClose® Drawers	Yes
Lighting	LED Sidewall and Theater Lighting
Freezer Shelves	4
Adjustable Shelves	3
Shelf Material	Glass w/Aluminum Profile
Full Extension Drawers @ 115° Door Opening Angle	Yes
General Use Drawer	2
Door Bins	4
External LED Proximity Sensor	No
Oversized Dispenser Opening	No
Chilled Water, Crushed and Cubed Ice	No
Rapid Water Replenishment System	No
Ice Maker with Diamond Ice System	Yes
Door Open Alarm	Yes
Open Door Assist	Yes
Special Modes	Sabbath, Economy, Vacation

**CAPACITY**

Total Capacity (cu. ft.)	15.8 cu. ft.
--------------------------	--------------

**PERFORMANCE**

Dedicated Evaporator & Compressor System	Yes
SuperFreeze®	Yes
Defrost Process	Frost-Free

**TECHNICAL DETAILS**

Watts (W)	350 W
Current (A)	15 A
Volts (V)	110-120 V
Frequency (Hz)	60 Hz
Power Cord Length (in.)	118
Plug Type	120V-3 Prong

**DIMENSIONS & WEIGHT**

Appliance Dimensions (H x W x D) (in.)	84"*** x 29 3/4" x 24"
Required Cutout Size (H x W x D) (in.)	84" x 30" x 25"
Net / Gross Weight (lbs)	362 / 398 lbs

**EFFICIENCY**

ENERGY STAR® Qualified	Yes
Annual Energy Consumption	479 kWh

\*To verify if you have a refrigeration unit with Soft-Close capability please contact our customer team by calling 1-800-735-4328.  
 \*\*Height adjustable + / - 1/2" (+ / - 13 mm)

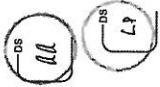

PV-85   
 March 22, 2021

**T30IF905SP**  
**30-INCH BUILT-IN FREEZER COLUMN WITH**  
**INTERNAL ICE MAKER**  
 FREEDOM® COLLECTION, PANEL-READY



WARRANTY	
Limited, Entire Appliance, Parts and Labor on Any Part of the Refrigerator that Fails Because of a Manufacturing Defect	2 Year
Limited Warranty for Sealed Refrigeration System*; Parts and Labor	3rd to 6th Year
Limited Warranty for Sealed Refrigeration System*; Parts Only	7th to 12th Year
Limited Warranty for Stainless Steel Rust-Through	Lifetime

\*Sealed refrigeration system includes compressor, evaporator, condenser, dryer / strainer and connection tubing

**CUTOUT DIMENSIONS**

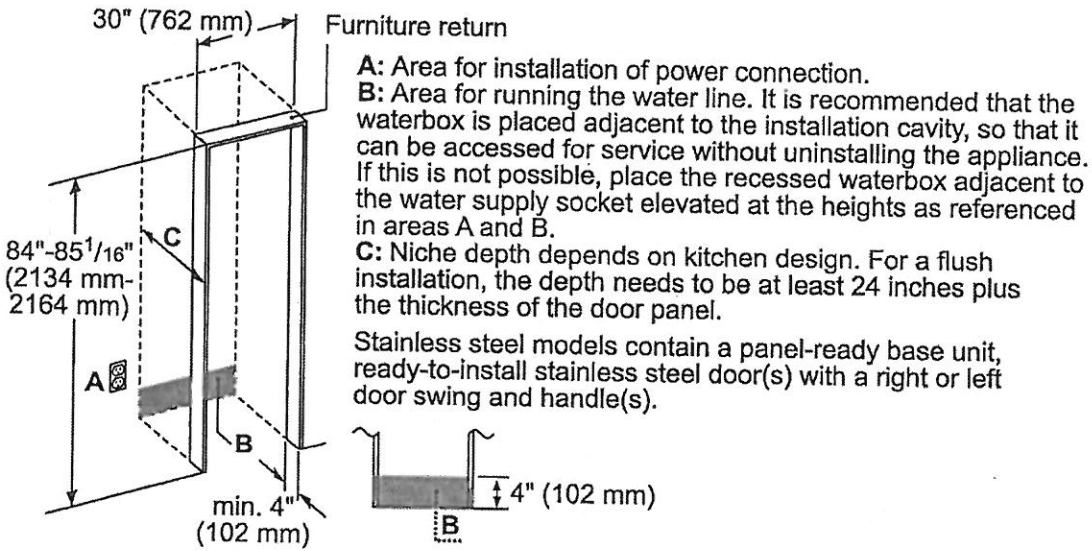

**TOP VIEW CLEARANCE**

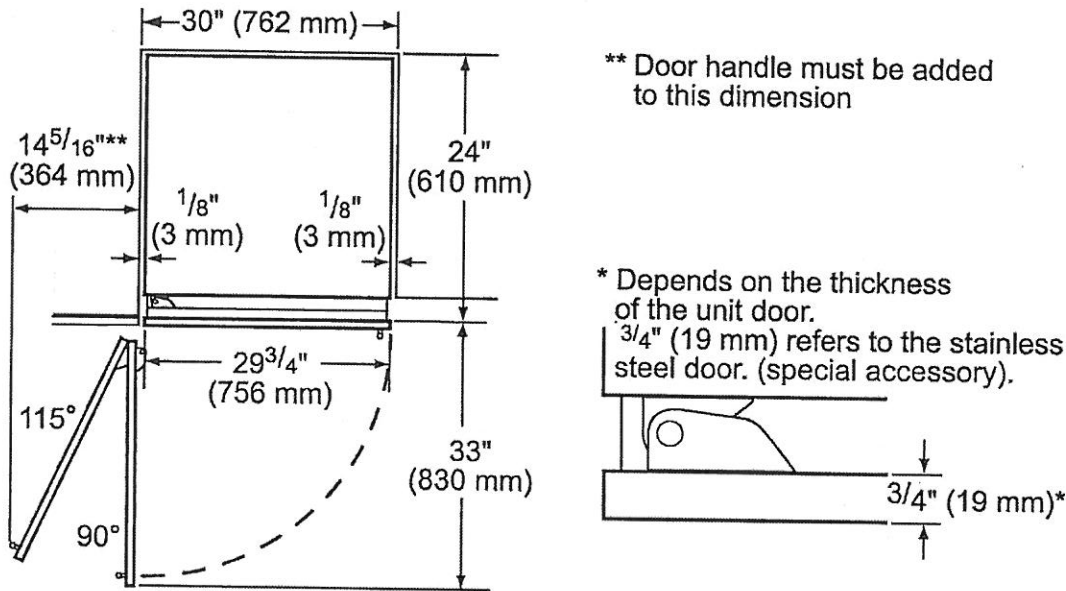

DocuSign Envelope ID: 6681413F-7A13-4D43-8FF4-319A43F4B349

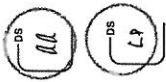
PV-95   
 March 22, 2021

**T30IF905SP**  
**30-INCH BUILT-IN FREEZER COLUMN WITH**  
**INTERNAL ICE MAKER**  
 FREEDOM® COLLECTION, PANEL-READY



**PRODUCT AND PANEL DIMENSIONS**

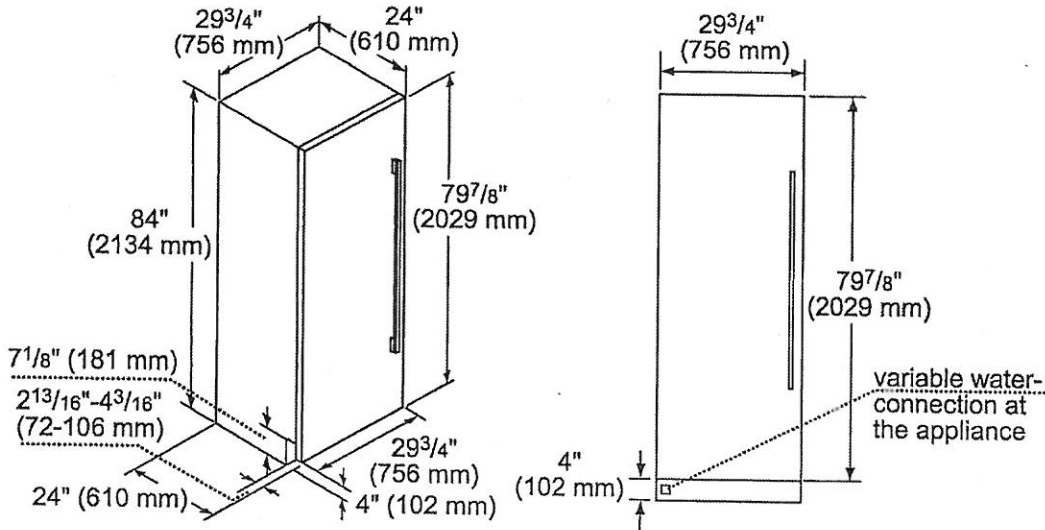

**ACCESSORIES (OPTIONAL)**

**FLAT STAINLESS STEEL DOOR PANELS**

30-Inch Flat Stainless Steel Door Panel Without Dispenser

-  **TFL30IR800**  
For use with Handle
- TFL30IR905**  
Handleless

**NOTE:** Handleless Panels should not be installed on units without the Soft-Close capability. If you are uncertain if you have a refrigeration unit with Soft-Close capability please contact our customer team by calling 1-800-735-4328.

**HANDLES**

Choose between two options:

-  **PR36HNDL20**  
36-Inch Professional Series Handle
- or
-  **MS36HNDL20**  
36-Inch Masterpiece® Series Handle

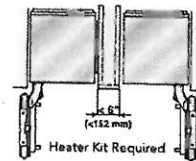

**HEATRKIT20 - 13W @ 120V**  
 Freedom® Heater Kit

When two appliances are installed side-by-side a sealing kit must be used. For combinations that involve a freezer column, this sealing kit is included. For all other (non-traditional, i.e. two wine columns, two bottom freezers, etc.) side-by-side combinations or instances where any appliances are installed less than 6-inches (152 mm) apart from one another but not connected side-by-side, purchase this kit. This kit is recommended for use with any installation in areas that are subject to humidity, or located next to an outside wall.

**STORAGE**

-  **ICEBUCKETL**  
Large Ice Bucket

**FILTERS**

-  **REPLFLTR55**  
Freedom® Water Filter  
Replacement water filter for use in all freezer and bottom freezer models

**FRAMEKIT10**

Freedom® Frame Kit  
 For any custom column installation in 24-inch deep cutouts. With two metal side trims whose placement between the interior cutout wall and the appliance helps overcome the challenge of unfinished cabinet returns.

These warranties give you specific legal rights and you may have other rights that vary from state to state. Limited warranty from date of purchase. For complete warranty details, refer to your Use & Care manual, or ask your dealer.

Specifications are for planning purposes only. Refer to installation instructions and consult your countertop supplier prior to making counter opening. Consult with a heating and ventilation engineer for your specific ventilation requirements. For the most detailed information, refer to installation instructions accompanying product or write to Thermador indicating the model number. Specifications are correct at time of printing. Thermador reserves the right to change product specifications or design without notice. Some models are certified for use in Canada. Thermador is not responsible for products that are transported from the U.S. for use in Canada.

1 800 735 4328 | USA THERMADOR.COM | CANADA THERMADOR.CA | ©2020 BSH HOME APPLIANCES CORPORATION. ALL RIGHTS RESERVED.

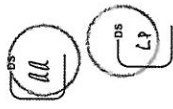
PV-85   
 March 22, 2021

**T36IR905SP**  
**36-INCH BUILT-IN FRESH FOOD COLUMN**  
 FREEDOM® COLLECTION, PANEL-READY

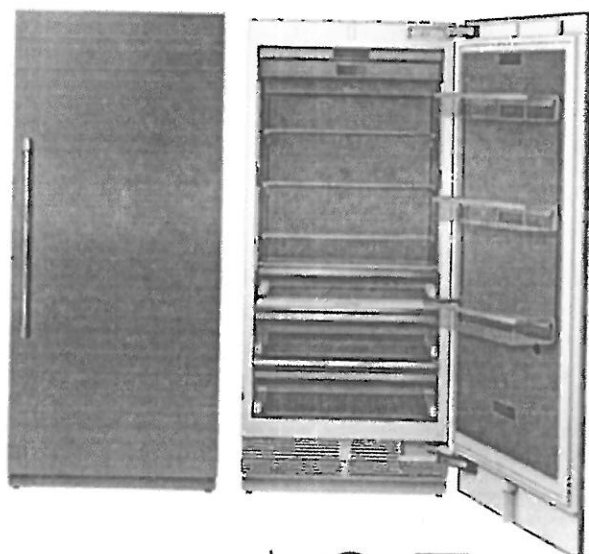

**FEATURES & BENEFITS**

- Full Stainless Steel Inner Liner
- Freedom® Hinge enables true flush design
- Auto Door Opening provides the opening of the door with just a slight push or pull
- ThermaFresh System, Humidity and Temperature controlled drawers
- SoftClose® Drawers for easy and controlled storage
- Sleek clean design for the perfect symmetry when paired with additional columns
- TFT control panel managing all your columns functions

**TEMPERATURE RANGES**

Refrigerator	36°F (2°C) to 46°F (8°C)
Temperature Controlled Drawer	30°F (-1°C) to 38°F (3°C)
SuperCool	36°F (2°C) for approximately 6 hours
Energy Saving (Economy) Mode	43°F (6°C)

**GENERAL PROPERTIES**

Home Connect™ (Wi-Fi Enabled)	Yes
Panel Ready	Yes
Reversible Door Swing	Yes
SoftClose® Door	Yes*
SoftClose® Drawers	Yes
Carbon Air Filter	Yes
Lighting	LED Sidewall and Theater Lighting
Refrigerator Shelves	4
Adjustable Shelves	3
Shelf Material	Glass w/Aluminum Profile
Full Extension Drawers @ 115° Door Opening Angle	Yes
Full Extension Drawers @ 90° Door Opening Angle	Yes
General Use Drawer	1
Humidity Managed Drawer	1
Temperature Controlled Drawer	1
Door Bins	3
Gallon Door Bins	1
Door Open Alarm	Yes
Open Door Assist	Yes
Special Modes	Sabbath, Economy, Vacation

**CAPACITY**

Total Capacity (cu. ft.)	20.6 cu. ft.
--------------------------	--------------

**PERFORMANCE**

Dedicated Evaporator & Compressor System	Yes
Freeflow® Cold Air System	Yes
SuperCool	Yes

**TECHNICAL DETAILS**

Watts (W)	350 W
Current (A)	15 A
Volts (V)	110-120 V
Frequency (Hz)	60 Hz
Power Cord Length (in.)	118
Plug Type	120V-3 Prong

**DIMENSIONS & WEIGHT**

Appliance Dimensions (H x W x D) (in.)	83 3/4*** x 35 3/4" x 24"
Required Cutout Size (H x W x D) (in.)	84" x 36" x 25"
Net / Gross Weight (lbs)	406 / 449 lbs

**EFFICIENCY**

ENERGY STAR® Qualified	Yes
Annual Energy Consumption	312 kWh

\*To verify if you have a refrigeration unit with Soft-Close capability please contact our customer team by calling 1-800-735-4328.  
 \*\*Height adjustable + / -1/2" (+ / -13 mm)

PV-85   
 March 22, 2021

**T36IR905SP**  
**36-INCH BUILT-IN FRESH FOOD COLUMN**  
 FREEDOM® COLLECTION, PANEL-READY



WARRANTY	
Limited, Entire Appliance, Parts and Labor on Any Part of the Refrigerator that Fails Because of a Manufacturing Defect	2 Year
Limited Warranty for Sealed Refrigeration System*; Parts and Labor	3rd to 6th Year
Limited Warranty for Sealed Refrigeration System*; Parts Only	7th to 12th Year
Limited Warranty for Stainless Steel Rust-Through	Lifetime

\*Sealed refrigeration system includes compressor, evaporator, condenser, dryer / strainer and connection tubing

**CUTOUT DIMENSIONS**

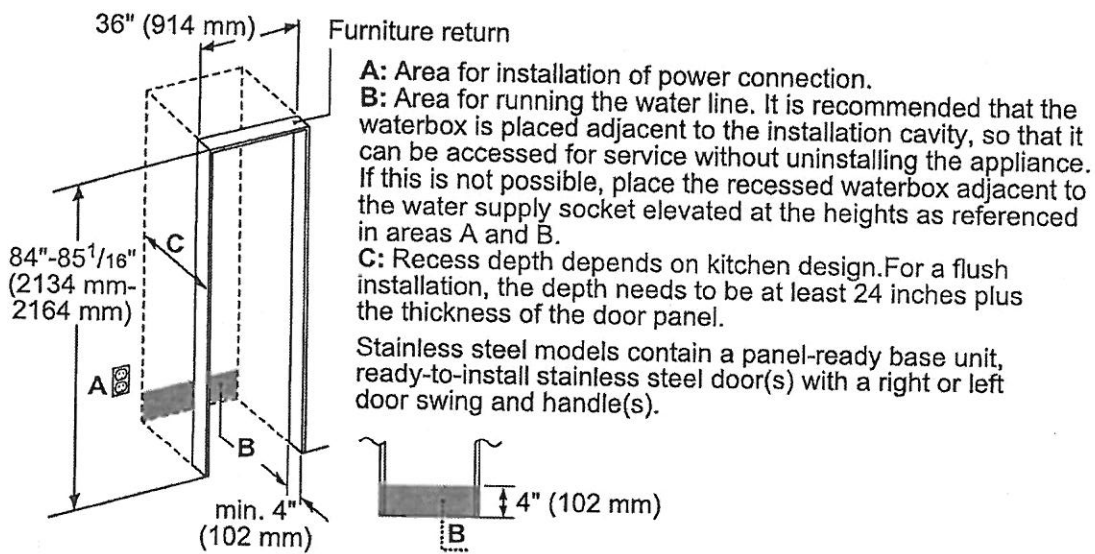

**TOP VIEW CLEARANCE**

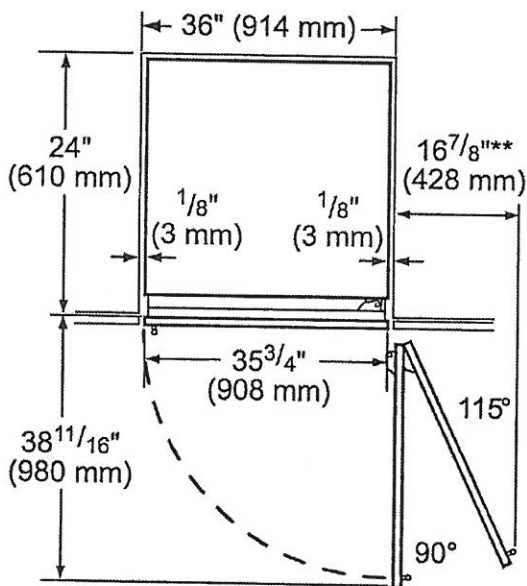

\*\* Door handle must be added to this dimension

\* Depends on the thickness of the furniture door. 3/4" (19 mm) is relevant for the stainless steel door. (special Accessory).

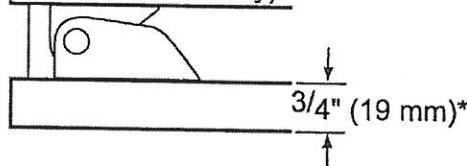

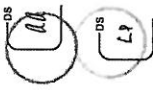
PV-85   
 March 22, 2021

**T36IR905SP**  
**36-INCH BUILT-IN FRESH FOOD COLUMN**  
 FREEDOM® COLLECTION, PANEL-READY



**PRODUCT AND PANEL DIMENSIONS**

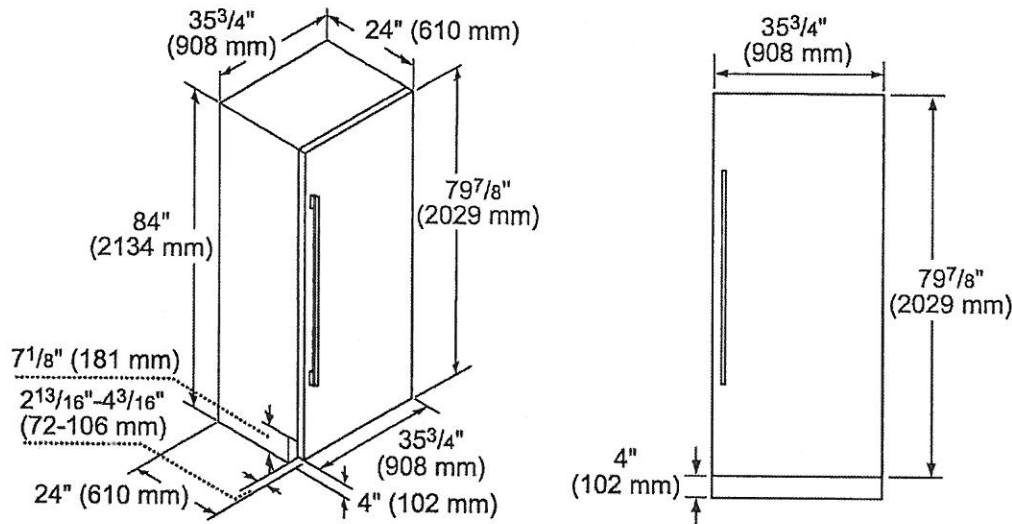

**ACCESSORIES (OPTIONAL)**

**FLAT STAINLESS STEEL DOOR PANELS**

30-Inch Flat Stainless Steel Door Panel



**TFL36IR900**  
 For use with Handle  
**TFL36IR905**  
 Handleless

**NOTE:** Handleless Panels should not be installed on units without the Soft-Close capability. If you are uncertain if you have a refrigeration unit with Soft-Close capability please contact our customer team by calling 1-800-735-4328.

**HANDLES**

Choose between two options:



**PR36HNDL20**  
 36-Inch Professional Series Handle

or

**MS36HNDL20**  
 36-Inch Masterpiece® Series Handle

**STORAGE**



**SPRODBIN10**  
 Small Produce Bin



**LPRODBIN10**  
 Large Produce Bin



**36PRODRAIL**  
 36-Inch Produce Railing



**36HFGALBIN**  
 36-Inch Half Gallon Bin

**FRAMEKIT10**

**Freedom® Frame Kit**  
 For any custom column installation in 24-inch deep cutouts. With two metal side trims whose placement between the interior cutout wall and the appliance helps overcome the challenge of unfinished cabinet returns.

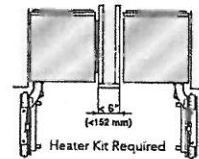

**HEATRKIT20 - 13W @ 120V**

**Freedom® Heater Kit**  
 When two appliances are installed side-by-side a sealing kit must be used. For combinations that involve a freezer column, this sealing kit is included. For all other (non-traditional, i.e. two wine columns, two bottom freezers, etc.) side-by-side combinations or instances where any appliances are installed less than 6-inches (152 mm) apart from one another but not connected side-by-side, purchase this kit. This kit is recommended for use with any installation in areas that are subject to humidity, or located next to an outside wall.

These warranties give you specific legal rights and you may have other rights that vary from state to state. Limited warranty from date of purchase. For complete warranty details, refer to your Use & Care manual, or ask your dealer.

Specifications are for planning purposes only. Refer to installation instructions and consult your countertop supplier prior to making counter opening. Consult with a heating and ventilation engineer for your specific ventilation requirements. For the most detailed information, refer to installation instructions accompanying product or write to Thermador indicating the model number. Specifications are correct at time of printing. Thermador reserves the right to change product specifications or design without notice. Some models are certified for use in Canada. Thermador is not responsible for products that are transported from the U.S. for use in Canada.

1 800 735 4328 | USA THERMADOR.COM | CANADA THERMADOR.CA | ©2020 BSH HOME APPLIANCES CORPORATION. ALL RIGHTS RESERVED.

PV-85    
 March 22, 2021

HOME APPLIANCES

LG LAUNDRY

**WM3800HBA**

5.2 cu.ft. Capacity Front Load Washer

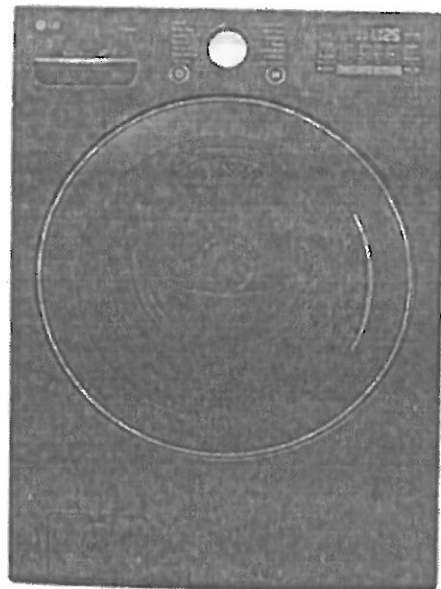

- TurboWash™ Technology
- Steam Technology
- SmartThinQ® Technology (Wi-Fi Enabled)
- 6Motion™ Technology
- 2018 ENERGY STAR Most Efficient
- Inverter BLDC Pump Motor
- SmartDiagnosis™



Enjoy new ways to control your home with LG smart appliances

SmartThinQ®

<b>CAPACITY</b>	
Capacity	5.2 cu.ft.
<b>APPEARANCE</b>	
Design Look	Front Control
Intelligent Electronic Controls with Dual LED Display	-
Touch Buttons	-
Dial-A-Cycle™	-
<b>ENERGY</b>	
2018 Energy Star Most Efficient	-
CEE Tier	2
<b>WASH PROGRAMS</b>	
No. of Programs	14
Normal, Heavy Duty, Bedding, Sanitary, Allergiene™, Bright Whites™, Tub Clean, Deep Wash, Perm. Press, Delicates, Towels, Speed Wash, Sportswear, Downloaded	
No. of Options	12
Steam, Fresh Care, Pre Wash, Remote Start, Delay Wash, Wi-Fi, Add Garments, TurboWash™, Cold Wash, Extra Rinse, Rinse+Spin, Control Lock	
No. of Wash/Rinse Temps	5
Extra Hot, Hot, Warm, Cold, Tap Cold	
Spin Speeds	Extra High, High, Medium, Low, No Spin
No. of Water Levels	Automatically adjusts to the size of load
No. of Soil Levels	5
<b>FABRIC CARE FEATURES</b>	
ColdWash™ Option	-
SenseClean™ System	-
Steam Technology	-
Allergiene™ Cycle	-
Sanitary Cycle	-
<b>CONVENIENCE FEATURES</b>	
4 Tray Dispenser	Prewash, Main Wash (with liquid detergent cup), Bleach, Fabric Softener
TrueBalance™ Anti-Vibration System	-
SmartDiagnosis™	-
LoadSense	-
Status Indicator(s)	-
End of Cycle Signal	-
Child Lock	-
Auto Suds Removal	-
Forced Drain System	-
LoDecibel™ Quiet Operation	-
Easy Loading TilTub™	-
Wi-Fi Connectivity	-
Energy Monitoring	-

**MOTOR AND AGITATOR**

Motor Type	Direct Drive Motor
Motor Speed	Variable
Max RPM	1,300
Axis	Horizontal

**MATERIALS AND FINISHES**

NeveRust™ Stainless Steel Drum	-
Cabinet	PCM
Control Panel	Plastic
Top Plate	Painted Steel
Door/Rim	Glass / Chrome (with Dark Blue Tinted Round Cover)
Available Colours	Black Steel (B)

**POWER SOURCE**

Ratings	UL Listed
Electrical Requirements	120V, 10 Amps
Type	Electric

**OPTIONS / ACCESSORIES**

Pedestal	WDP4B
Pedestal Dimensions (WxHxD)	27" x 14 1/8" x 28 2/5"
SideKick™ Pedestal Washer	WD100CB
SideKick™ Pedestal Washer (WxHxD)	27" x 14 1/8" x 30 3/4" (50 9/16" with door open)
Stacking Kit	KSTK1
Hose Included	No
<b>DIMENSIONS</b>	
Product (WxHxD)	27" x 39" x 30 1/4" (55"D with door open)
Carton (WxHxD)	29 1/2" x 43 5/16" x 31 5/16"
Weight (Product/Carton)	187.4 lbs / 209.4 lbs

**LIMITED WARRANTY**

1 Year Parts and Labour, 3 Years on Drum, 10 Years on Direct Drive Motor

**UPC CODES**

WM3800HBA Washer (Black Steel)	772454071720
DLEX3900B Electric Dryer (Black Steel)	772454071737
DLGX3901B Gas Dryer (Black Steel)	772454071744

© 2018 LG Electronics Canada, Inc. All rights reserved. "LG Life's Good" is a registered trademark of LG Corp. All other product and brand names are trademarks or registered trademarks of their respective owners. Design, features and specifications are subject to change without notice. Non-metric weights and measurements are approximate. Some features may require Internet access. Content and services may vary by product and are subject to change without notice. 05/01/2018

20 Norelco Drive, North York, Ontario M9L 2X6 Tel: 647-253-6300 | Customer Service & Parts 1-888-542-2623

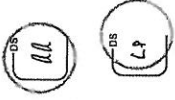
PV-88   
 March 22, 2021

## Choosing the Proper Location

Install the washer on a solid floor that is strong and rigid enough to support the weight of the washer, even when fully loaded, without flexing or bouncing. If the floor has too much flex, you may need to reinforce it to make it more rigid. If the floor is not solid, it may cause severe vibration and noise.

### NOTE

- Before installing the washer, make sure the floor is clean, dry and free of dust, dirt, water and oil so the washer feet cannot slide easily. Leveling feet that can move or slide on the floor can contribute to excess vibration and noise due to poor contact with the floor.
- If a drip pan must be used, take extra care to follow the instructions provided with the drip pan and make sure the leveling feet are adjusted for firm and even contact with the pan. Use of drip pans and failure to properly level the machine may result in increased vibration and noise during operation.
- Allow for sufficient space between the walls and the washer for installation.

## Power Outlet

- The power outlet must be within 60 inches (1.5 m) of either side of the washer.
- The appliance and outlet must be positioned so that the plug is easily accessible.
- Do not overload the outlet with more than one appliance.
- The outlet must be grounded in accordance with current electrical wiring codes and regulations.
- Use a time-delay fuse or circuit breaker.

### NOTE

- It is the personal responsibility and obligation of the product owner to have a proper outlet installed by qualified service personnel.

## Flooring

- To minimize noise and vibration, the washer must be installed on a solidly constructed floor.
- Allowable slope under the entire washer is a maximum 1 inch (2.5 cm) difference from side to side or from front to back.
- Installing on carpeting and soft tile surfaces is not recommended.
- Never install the washer on a platform or weakly supported structure.

### NOTE

- The washer must be installed on firm flooring to minimize vibration during the spin cycle. Concrete flooring is best, but a wood floor is sufficient, provided it is built to FHA standards.

## Floor Installation

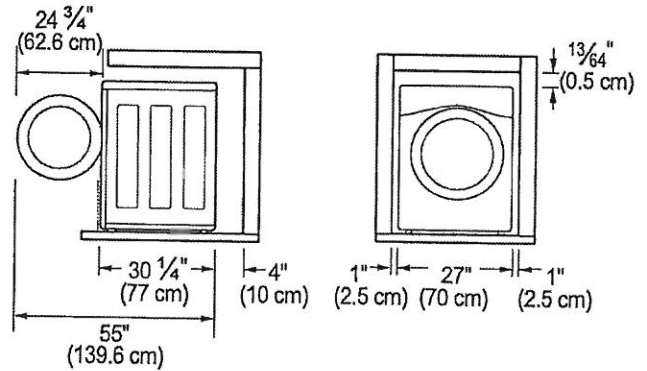

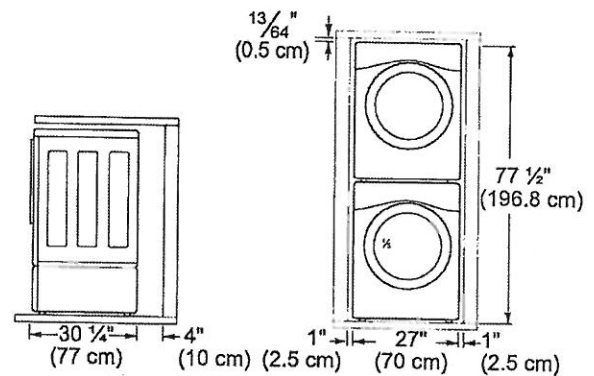

To ensure sufficient clearance for water lines, the drain line and airflow, allow minimum clearances of at least 1 inch (2.5 cm) at the sides and 4 inches (10 cm) behind the unit. Be sure to allow for wall, door, or floor moldings that may increase the required clearances.

## Stacked or Pedestal Installation



### NOTE

- Refer to the instructions packaged with the optional pedestal kit before installing with a pedestal kit.
- Do not use a drip pan with a pedestal or pedestal washer installation as it can block the drawer. Using a drip pan may result in increased vibration and noise during operation.

PV-85    
 March 22, 2021

HOME APPLIANCES

LG LAUNDRY

DLEX3900\_ / DLGX3901\_

7.4 cu.ft. Front Load Dryer with TurboSteam™



KEY FEATURES

- 7.4 cu. ft. Capacity
- TurboSteam™ Technology
- LG SmartThinQ® Technology
- Sensor Dry System
- FlowSense™ Duct Clogging Indicator
- ENERGY STAR® Qualified
- Electronic Control Panel with Dual LED Display

AVAILABLE COLORS

-  WHITE
-  BLACK STEEL

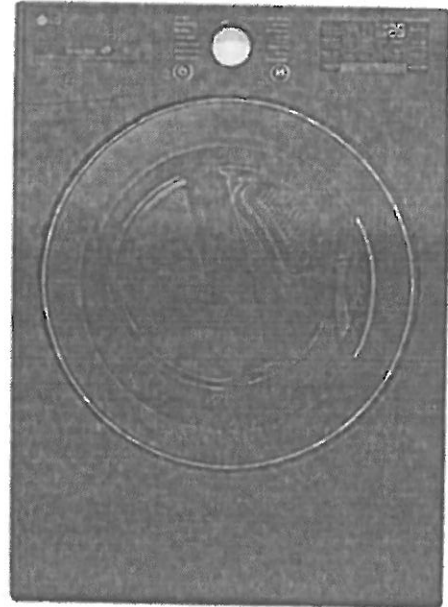

SMART APPLIANCE



Enjoy new ways to control your home with LG smart appliances

- Start the laundry while you're out shopping
- Get alerts when the cycle is finished
- Works with the LG SmartThinQ® app

SmartThinQ®

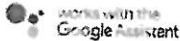

PRODUCT FEATURES

SUMMARY		FABRIC CARE FEATURES		POWER SOURCE	
Type	Front Load Dryer	Sensor Dry	Yes	Ratings	CSA Listed
Capacity	7.4 cu. ft.	Precise Temperature Control with Variable Heater	Yes	Electrical Requirements	Electric: 240V 30 Amps Gas: 120V, 15 Amps
Matching Washer	WM3900HWA / WM3900HBA	Steam	TurboSteam™	Type	Electric / Gas
Sensor Dry	Yes	<b>CONVENIENCE FEATURES</b>		BTU Rating	10,000 Feet
Colors	White (W) / Black Steel (B)	3 Minute Installation Check	Yes	<b>OPTIONS</b>	
<b>APPEARANCE</b>		LoDecibel™ Quiet Operation	Yes	LP Conversion Kit	383EEL3002D
Intelligent Electronic Controls with LED Display	Yes	End of Cycle Signal	Yes	Side Venting Kit	383EEL9001B
Dial-A-Cycle™	Yes	Drum Light	Yes	Pedestal	WDP4W / WDP4B
Touch Buttons	Yes	Reversible Door	Yes	Pedestal (WxHxD)	27 x 14 1/8 x 30 3/4 (50 1/2 D with door open)
<b>ENERGY</b>		FlowSense™ Duct Clogging Indicator	Yes	<b>DIMENSIONS</b>	
ENERGY STAR® Qualified	Yes	Wrinkle Care Option	Yes	Product (WxHxD)	27" x 38 11/16" x 30"
<b>DRYER PROGRAMS</b>		Child Lock	Yes	Depth with Door Open	51"
No. of Programs	14	Venting Option	Electric: 4 Way Venting Gas: 3 Way Venting	Carton (WxHxD)	29 19/32" x 43 3/8" x 31 3/8"
	Normal, Heavy Duty, Bedding, Small Load, Anti Bacterial, SteamSanitary™, SteamFresh™, Perm Press, Delicates, Sportswear, Towels, Speed Dry (Manual Dry), Air Dry (Manual Dry), Downloaded	4 Adjustable Legs	Yes	Weight (Product)	Electric: 123lbs Gas: 125.7lbs.
<b>DRYER OPTIONS</b>		Remaining Time Display/Status Indicator(s)	Yes	Weight Carton	Electric: 136.2lbs. Gas: 138.9lbs.
No. of Options	13	<b>SmartThinQ® SMART FEATURES</b>		<b>LIMITED WARRANTY</b>	
	More Time, Less Time, Damp Dry Signal, Wrinkle Care, Control Lock, Custom Program, PGM Save, Wi-Fi Connect, Energy Saver, TurboSteam™, Reduce Static, Smart Grid, Remote Start	SmartDiagnosis™	Yes	Parts & Labor	1 Year
<b>DRYER DETAILS</b>		Wi-Fi Connectivity	Yes	<b>UPC CODES</b>	
Temperature Settings	High, Medium High, Medium, Low, Ultra Low	Remote Control	Yes	DLEX3900W (Electric / White)	048231025195
Drying Levels	Very Dry, More Dry, Normal Dry, Less Dry, Damp Dry	Cycle Monitoring and Notification	Yes	DLEX3900B (Electric / Black Steel)	048231026437
Manual Dry Times	60 min., 50 min., 40 min., 30 min., 20 min., More Time/Less Time	Energy Monitoring	Yes	DLGX3901W (Gas / White)	048231025201
		<b>MATERIALS AND FINISHES</b>		DLGX3901B (Gas / Black Steel)	048231026444
		Aluminized Alloy Steel Drum	Yes		
		Tub Rear	Painted		
		Cabinet	Painted Steel		
		Door	Round w/ Chrome trim		

© 2019 LG Electronics USA, Inc. All rights reserved. "LG Life's Good" is a registered trademark of LG Corp. All other product and brand names are trademarks or registered trademarks of their respective owners. Design, features and specifications are subject to change without notice. Non-metric weights and measurements are approximate. Some features may require Internet access. Content and services may vary by product and are subject to change without notice. 2/7/19



PV-85 (11) (12)  
 March 22, 2021

# PRODUCT OVERVIEW

## Parts

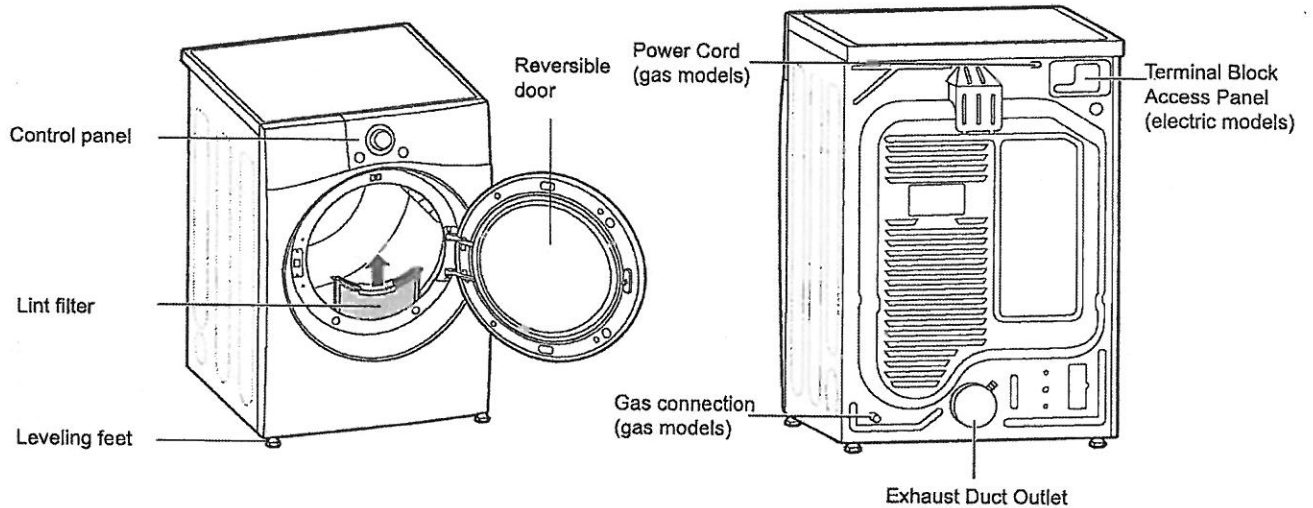

## Product Specifications

The appearance and specifications listed in this manual may vary due to constant product improvements.

Dryer Models		DLE3500* / DLG3501*	DLEX3700* / DLGX3701*	DLEX3900* / DLGX3901*
Description		Non-steam Dryer	Steam Dryer	Steam Dryer
Electrical requirements		Please refer to the rating label for detailed information.		
Gas requirements		NG: 4 - 10.5-inch (10.2 - 26.7 cm) WC LP: 8 - 13-inch (20.4 - 33.1 cm) WC		
Dimensions		27" (W) X 30.2" (D) X 39" (H), 51.4" (D with door open) 68.6 cm (W) X 76.5 cm (D) X 99 cm (H), 130.5 cm (D with door open)		
Net weight		Gas : 123.02 lb (55.8kg) - 126.77 lb (57.5kg) Electric : 120.15 lb (54.5kg) - 123.46 lb (56kg)		
Drying capacity	Steam Cycle	-	IEC 7.4 cu.ft. (8 lb/3.6 kg)	
	Normal Cycle	IEC 7.4 cu.ft. (22.5 lb/10.2 kg)		

**NOTE**

Model numbers can be found on the cabinet inside the door.

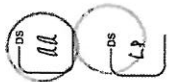
PV-85   
 March 22, 2021

## 12 INSTALLATION

### Clearances

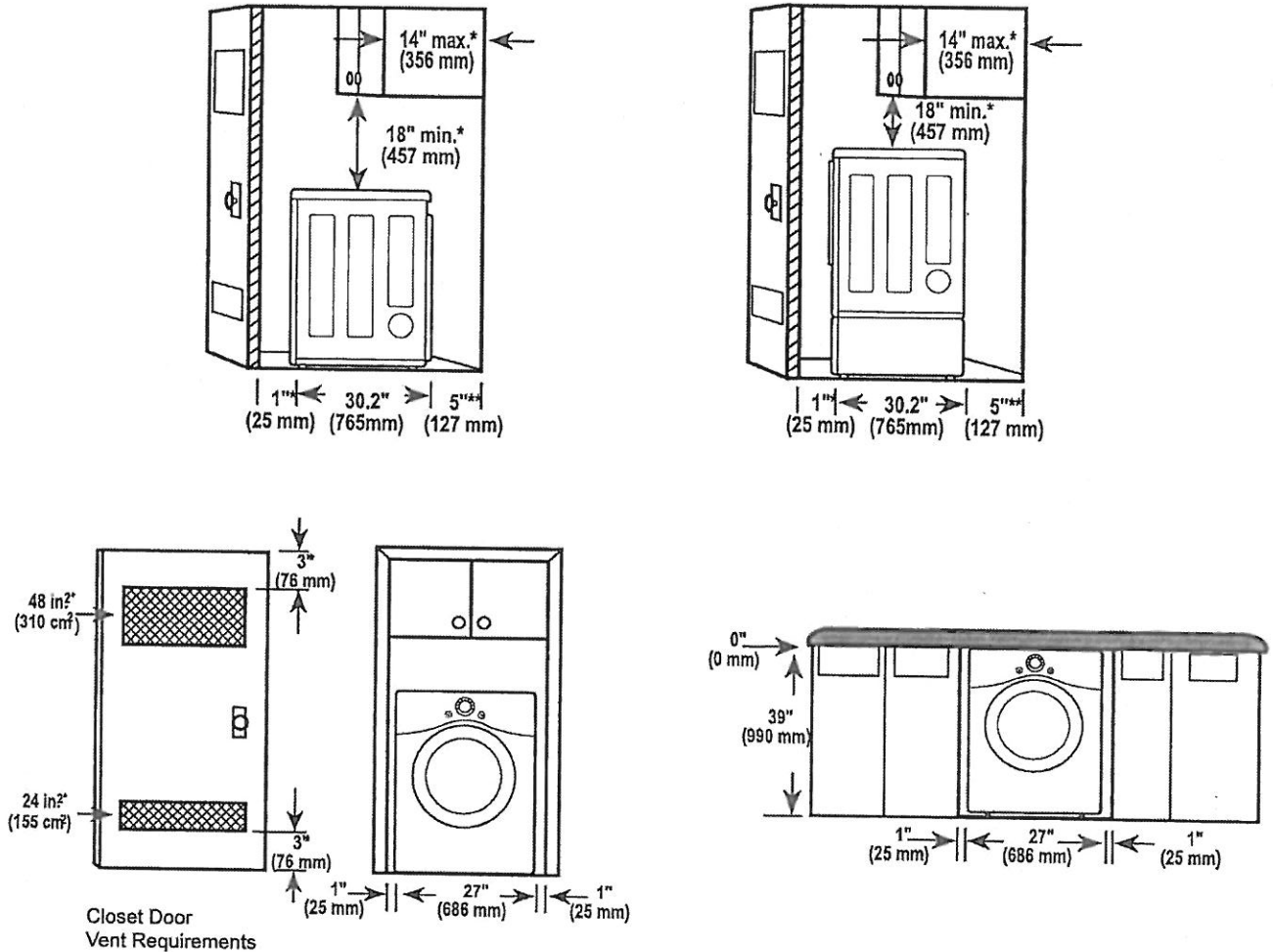

### Installation Spacing for Recessed Area or Closet Installation

The following clearances are recommended for this dryer. This dryer has been tested for clearances of 1 inch (2.5 cm) on the sides and rear. Recommended clearances should be considered for the following reasons:

- Additional clearances should be considered for ease of installation and servicing.
- Additional clearances should be considered on all sides of the dryer to reduce noise transfer. For closet installation, with a door, minimum ventilation openings in the top and bottom of the door are required. Louvered doors with equivalent ventilation openings are acceptable.

#### Closet Ventilation Requirements

Closets with doors must have both an upper and lower vent to prevent heat and moisture buildup in the closet. One upper vent opening with a minimum opening of 48 sq. in. (310 cm<sup>2</sup>) must be installed no lower than 6 feet above the floor. One lower vent opening with a minimum opening of 24 sq. in. (155 cm<sup>2</sup>) must be installed no more than one foot above the floor. Install vent grills in the door or cut down the door at the top and bottom to form openings. Louvered doors with equivalent ventilation openings are also acceptable.

#### NOTE

- There should be at least a little space around the dryer (or any other appliance) to eliminate the transfer of vibration from one appliance to another. If there is enough vibration, it could cause appliances to make noise or come into contact, causing paint damage and further increasing noise.

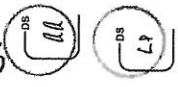
PV-85   
 March 22, 2021

### Installation Spacing for Recessed Area or Closet, with Stacked Washer and Dryer

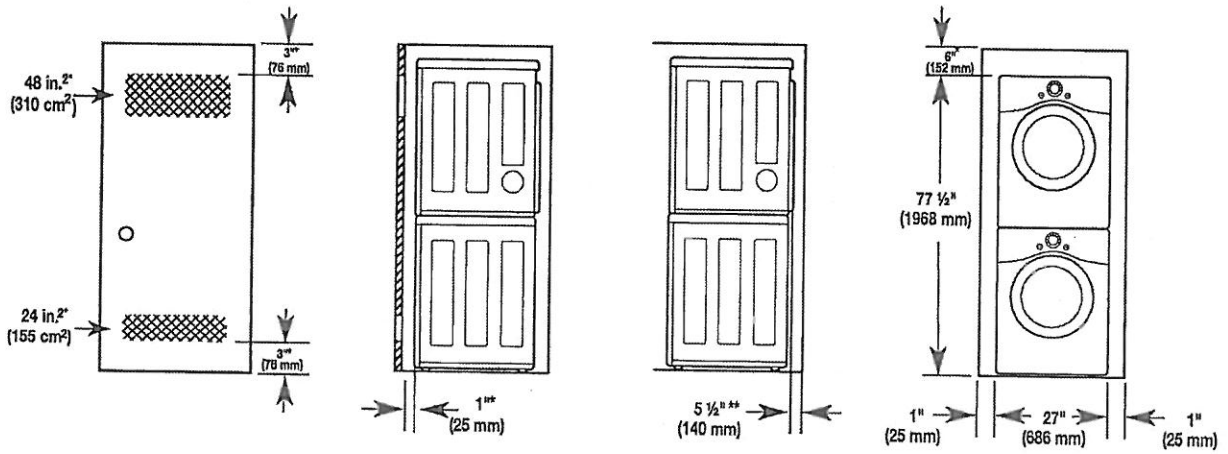

\* Required spacing

\*\* For side or bottom venting, 2-inch (5.1 cm) of spacing is allowed.

### Installation Spacing for Cabinet

For cabinet installation with a door, minimum ventilation openings in the top of the cabinet are required.

\* Required spacing

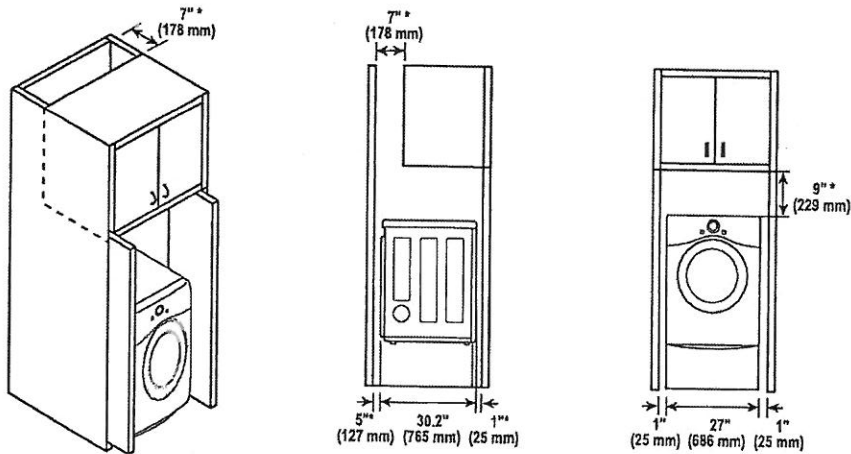

ENGLISH

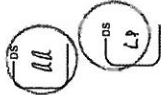
PV-85   
 March 22, 2021

# SAXONY

SPRBC056D1SS



## BENEFITS

<b>Model #</b>	SPRBC056D1SS
<b>Capacity-Wine Compartment</b>	Stores up 126 beverage cans and 6 bottles of wine
<b>Volume</b>	5.6 cu. ft.
<b>Temperature Range</b>	34F - 50F (1C-10C)
<b>Noise</b>	39 db
<b>Door Frame</b>	304 grade seamless stainless steel
<b>Cabinet</b>	Matte black textured steel
<b>Interior Finish</b>	Matte black
<b>Door Style</b>	Single door
<b>Reversible Door Swing</b>	Yes
<b>Door Hinge</b>	Hidden for flush fit installation
<b>Door Glass</b>	Low E, dual pane argon filled
<b>Door Handle</b>	Pro-style, 20% longer than previous model
<b>Door Lock</b>	Yes
<b>Shelving Material</b>	3 adjustable clear glass shelves
<b>Lighting Option 1</b>	On/Off with door opening
<b>Lighting Option 2</b>	On 100% illumination for 2 hours
<b>Lighting Option 3</b>	On 50% illumination for 2 hours
<b>Light Colours</b>	Choose between Arctic white or Azure blue
<b>Controls</b>	Digital seamless capacitive touch
<b>Temperature Recall</b>	Yes reverts to last set temperature after power outage
<b>Alarm</b>	Yes, temperature and door ajar
<b>Sabbath Mode</b>	Yes

## PRODUCT SPECIFICATIONS

**UPC** 067638024273

### Unit Dimensions

Width 23.8" in.  
 Min. Height 34" in.  
 Max. Height 34.7" in.  
 Depth 23.8" in.  
 (DOES NOT INCLUDE HANDLE)

### Installation

Gross Weight: 136 lbs.  
 Built-in under counter or free standing Refrigerator: R600  
 Size: Min 24" wide opening required

### AC Power

115V, 60Hz at MAX 1.5A  
 Power cord length: 6.5 ft.

### Platinum Warranty

2 year parts and labor coverage

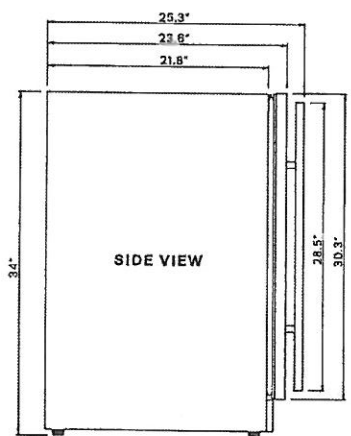
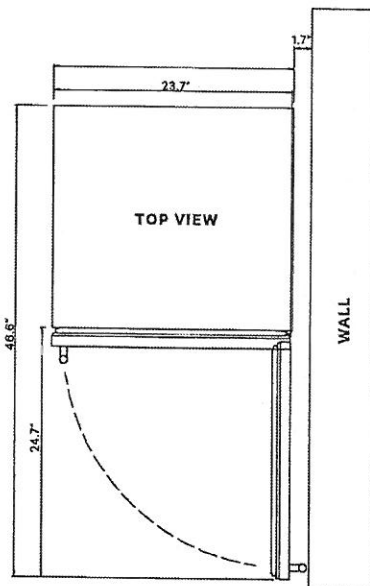
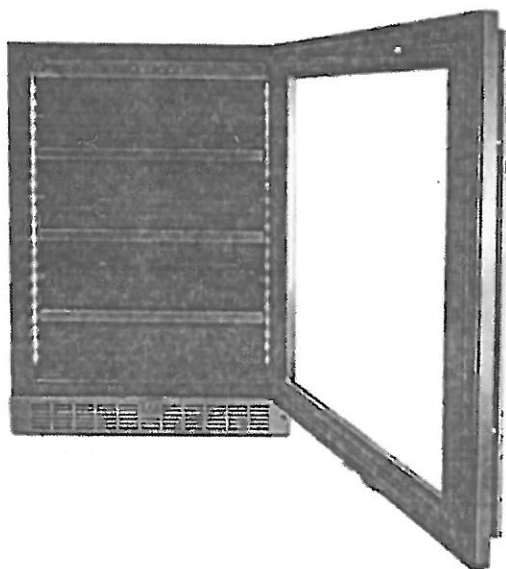

\*based on standard 750ml bordeaux style bottle

Danby USA 1-866-649-3309 Danby Canada 1-800-461-4492  
 03.09.20-V4

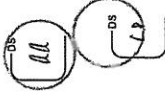
PV-85   
 March 22, 2021

## INSTALLATION INSTRUCTIONS

### PREPARING THE ENCLOSURE

Gloves and safety goggles should be worn during installation.

It is not recommended to install the appliance into a corner or directly beside a wall. The door will need to be opened more than 90° to allow full extension of the shelves. If it is necessary to place the unit next to a wall or in a corner, leave at least 2-4 inches (5-10 cm) of space between the wall and the appliance to allow for the door opening.

The cabinet opening must be at least 24 inches (61 cm) wide by 35 inches (88.9 cm) high by 25 inches (63.5 cm) deep.



**Note:** The listed depth requirement is assuming that the electrical outlet is located in the adjacent cabinetry or flush mounted in the rear wall, not surface mounted inside the enclosure.

If the electrical outlet is located inside adjacent cabinetry, cut a 1.5 inch (3.8 cm) diameter hole to admit the power cord. If the cabinet wall is metal, the hole edge must be covered with a bushing or grommet.

### REQUIRED TOOLS

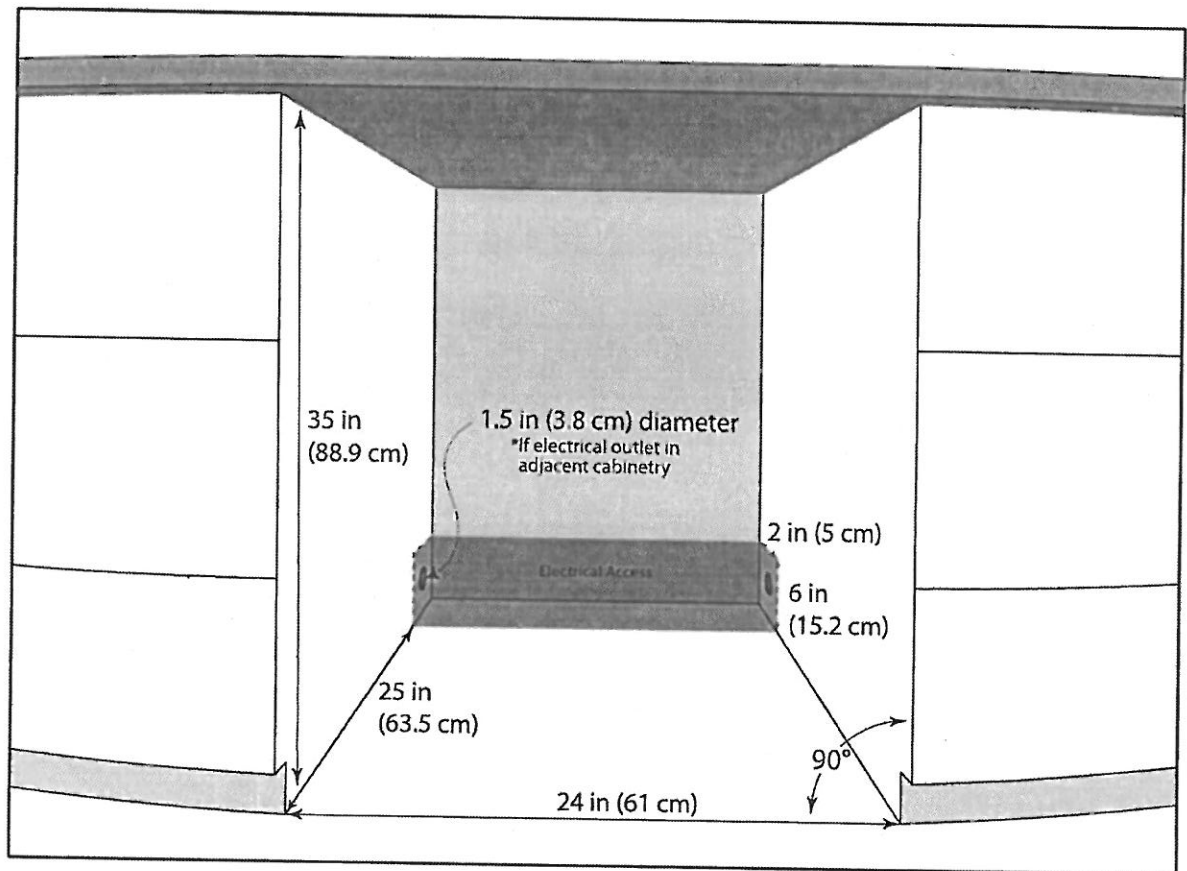
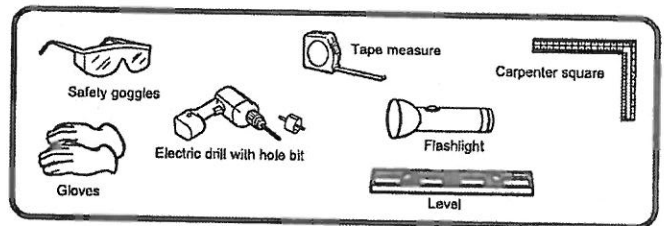
- Safety goggles
- Gloves
- Tape measure
- Carpenter square
- Level
- Flashlight
- Electric drill with hole bit



PV-85    
 March 22, 2021



Microwave Ovens Countertop  
**Countertop NN-ST681SC**

Model Number		NN-ST681SC
Type		Mid-size
Capacity		1.2 cu.ft.
Technology		Inverter®
Power	Microwave	1,200 W
	Grill	NA
	Grill Power Level	NA
	Convection	NA
Combination	Microwave + Grill	NA
	Power Level	NA
Design	Colour	Stainless Steel
	Dial / Button	-
	Door Release	Push Open
	Finish	Half Mirror
Control Panel	Panel Design	Touch pad
Display	Type	4 Digit
	Colour	Green
	Back Light	yes
Power Level + Other.	Power Level	10
	Delay Start	yes
	Clock	12 Hour
	Child Lock	yes
	Stage Cooking	3 Stage
Menu	Sensor	yes

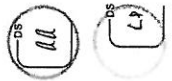
PV-85   
 March 22, 2021

	Turbo Defrost	yes
	Popcorn	yes
	Keep Warm	yes (up to 30 minutes)
	Quick Min	yes (up to 10 minutes)
	Auto Reheat	Sensor Reheat
	# of Auto Cook Categories	12
Turntable Size		340 mm
Accessory		Glass Tray
Trim Kit		NNTK621S
Power Source		120 V / 60 Hz
Power Consumption	Microwave	1,480 W
	Grill	NA
	Combination	NA
Cooking Power	Microwave	1,200 W
	Grill	NA
Dimensions	Outside (W x D x H)	525 x 401 x 310 mm 20.7 x 15.8 x 12.3 inch
	Oven (W x D x H)	355 x 365 x 251 mm 13.9 x 14.4 x 9.9 inch
Weight	Net	11.5 kg
	Shipping	13.0 kg
NOTE		Specifications are subject to change without notice.

Copyright ©Panasonic Canada Inc.

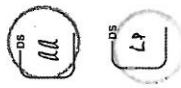
PV-85   
 March 22, 2021

**VCIN36GWS**  
**36-INCH CUSTOM INSERT**  
 PROFESSIONAL® SERIES

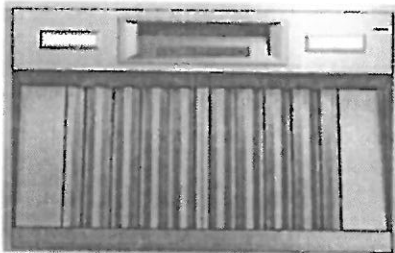

**FEATURES & BENEFITS**

- Revel in creative freedom with Professional® Series custom inserts that can blend in with cabinetry or make a bold statement
- ★ Equipped with the Thermador Connected Experience by Home Connect™
- Powerfully Quiet® system accepts integral, inline, and remote blowers
- Beautiful illumination with multi-level, vivid LED lights
- Features automatic mode, delay shut-off, and check filter light

**ACCESSORIES (OPTIONAL)**

25 ft. Blower Connector Cable - EXTNCB25W  
 For use with the following inline and remote blowers: VTR630W, VTR1030W, VTR1330W, VT1610W, VT11010W

Roofplates

RFPLT600P - For use with 600 CFM remote blower VTR630W  
 RFPLT1000P - For use with 1000 CFM remote blower VTR1030W and 1300 CFM blower VTR1330W

VCIN Trim Notes

NOTE: VCIN\_GWS series custom insert models include hood trim pieces to complete the installation.

Remote Control Panel

REMCPUW - Ability to vertically install on cabinetry or wall to control hood in a convenient location



**GENERAL PROPERTIES**

**Features**

Multi-Level LED Lights with Fading Transitions, Automatic Mode, Check Filter Reminder Light, Delay Shut-Off

Operating Mode	Ducted
Maximum CFM	Blower Sold Separately
Number of Speed Settings	4-Stage
Number of Lights	2
Bulb Type	LED
Light Lumens	100 – 150
Light Color (°K)	3500 – 4000
Total Power of the Lamps (W)	2.4 W
Damper Included	Yes
Grease Filter Material	Washable Stainless Steel
Grease Filter Type	Stainless-Steel Commercial Style Baffle Filter
Home Connect™ (Wi-Fi Enabled)	Yes

**TECHNICAL DETAILS**

Watts (W)	See Chart on Page 3
Current (A)	See Chart on Page 3
Volts (V)	120 V
Frequency (Hz)	60 Hz
Plug Type	Fixed Connection
Power Cord / Conduit Length (in)	Direct Wire at Junction Box

**DIMENSIONS & WEIGHT**

Overall Appliance Dimensions (Width of Canopy Included) (HxWxD) (in)	12 13/16" x 33 3/4" x 22"
Minimum Required Distance Above Gas / Electric Cooking Surface	30" Electric / 30" Gas
Diameter of Air Duct (in.) Top	10"
Net Weight (lbs)	54 lbs

**ACCESSORIES (REQUIRED)**

Blower (Sold Separately)

**BLOWER OPTIONS**

Remote Blowers (Mounted to Roof or External Wall)	VTR630W - 600 CFM
	VTR1030W - 1000 CFM
	VTR1330W - 1300 CFM
Inline Blowers (Mounted Between Kitchen and External Wall)	VT1610W - 600 CFM
	VT11010W - 1000 CFM
Integrated Blower (Mounted in Hood)	VTN630W - 600 CFM
	VTN1090R - 1000 CFM

**WARRANTY**

Limited Warranty Parts and Labor	2 Year
----------------------------------	--------

★ THERMADOR® EXCLUSIVE



PV-85   
 March 22, 2021

**VCIN36GWS**  
**36-INCH CUSTOM INSERT**  
 PROFESSIONAL® SERIES



**HOOD DIMENSIONS**

NOTE: VCIN Custom Insert models include hood trim pieces.

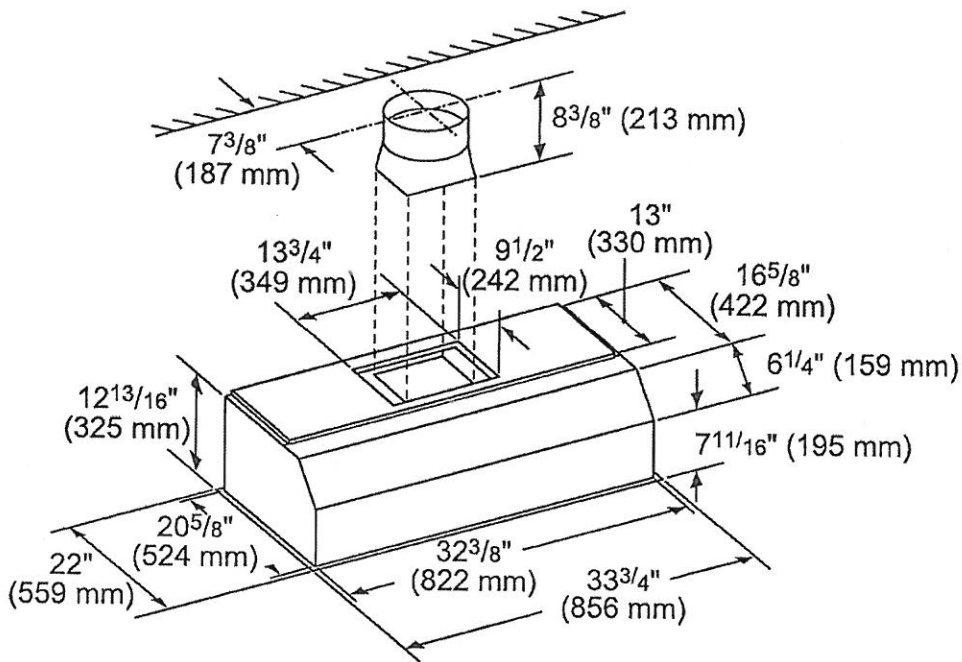
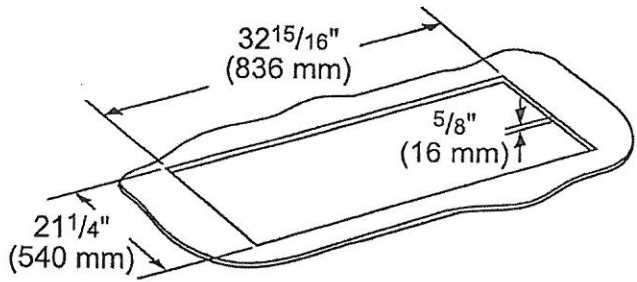

measurements in inches (mm)

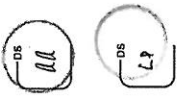
PV-85   
 March 22, 2021

**VCIN36GWS**  
**36-INCH CUSTOM INSERT**  
 PROFESSIONAL® SERIES



MODEL	DESCRIPTION		ELECTRIC LOAD						
			VTN630W	VTN1090R	VTI610W	VTI1010W	VTR630W	VTR1030W	VTR1330W
VCIN36GWS	36" Custom Insert	Amps	4.0	7.4	5.9	7.8	5.9	7.8	11.3
		Watts	480	888	708	936	708	936	1,356

REMOTE BLOWERS (MOUNTED TO ROOF OR EXTERNAL WALL)

VTR630W-600 CFM

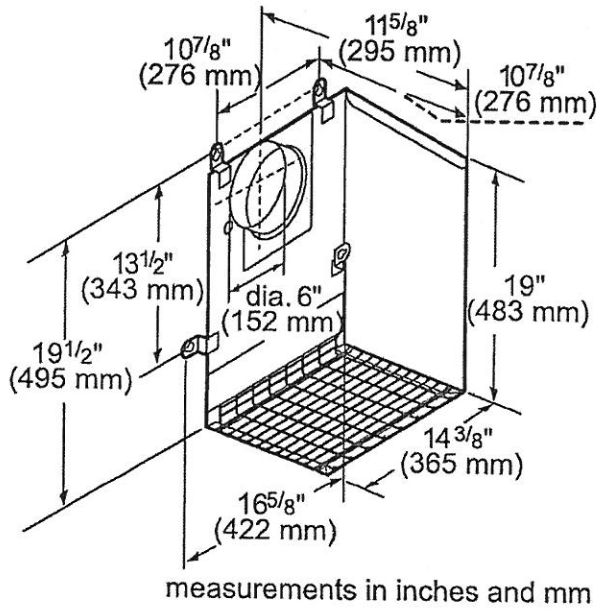

VTR1030W-1000 CFM

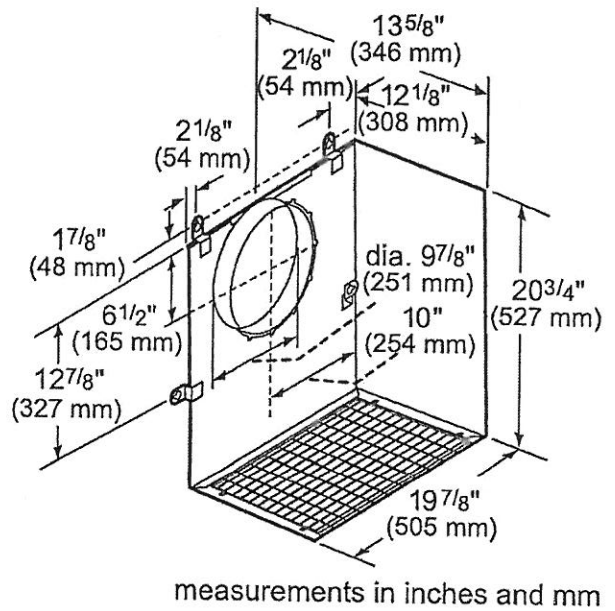

VTR1330W-1300 CFM

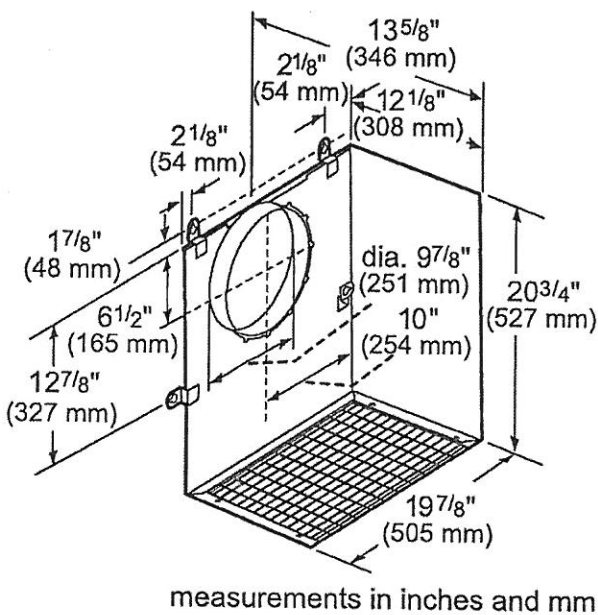

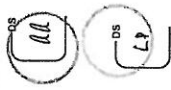
PV-85   
 March 22, 2021

**VCIN36GWS**  
**36-INCH CUSTOM INSERT**  
 PROFESSIONAL® SERIES



**INLINE BLOWERS (MOUNTED BETWEEN KITCHEN AND EXTERNAL WALL)**

VTI610W-600 CFM

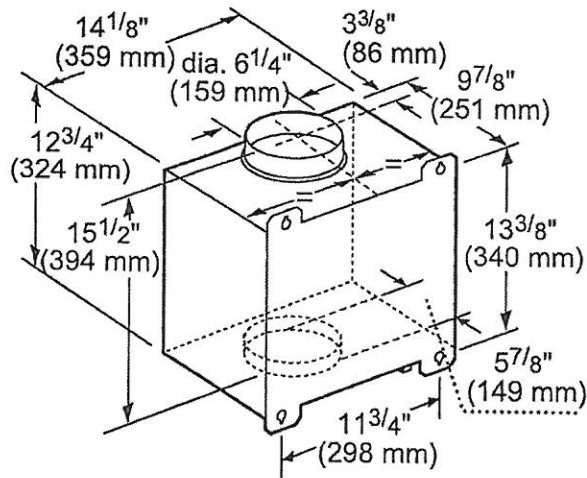

measurements in inches and mm

VTI1010W-1000 CFM

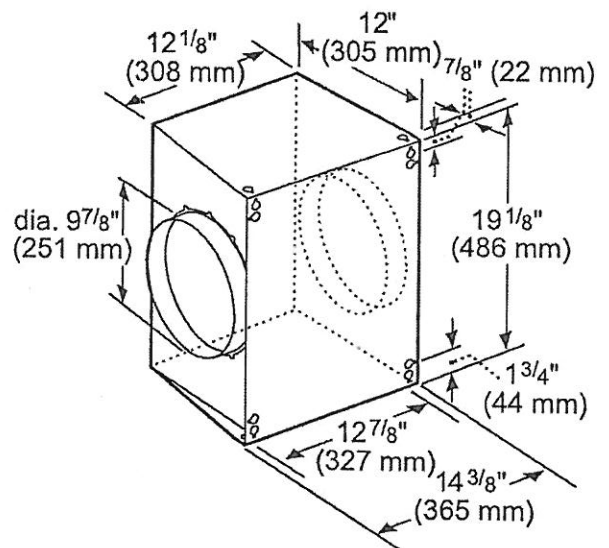

measurements in inches and mm

**INTEGRATED BLOWERS (MOUNTED IN HOOD)**

VTN630W-600 CFM

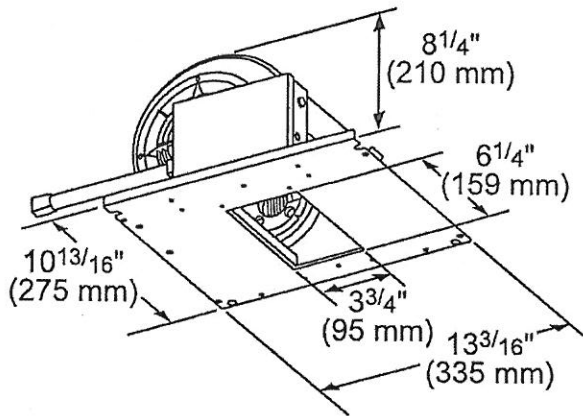

measurements in inches (mm)

VTN1090R-1000 CFM

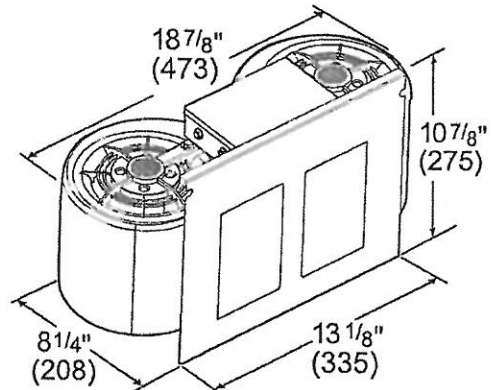

measurements in inches and mm

PV-85  

March 22, 2021

**VCIN36GWS**  
**36-INCH CUSTOM INSERT**  
 PROFESSIONAL® SERIES



REMOTE BLOWER ACCESSORIES

ROOFPLATE-RFPLT600P

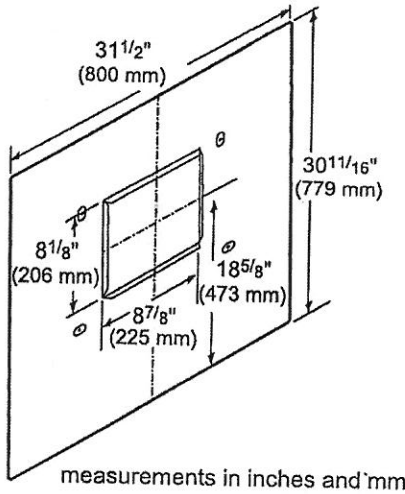

ROOFPLATE-RFPLT1000P

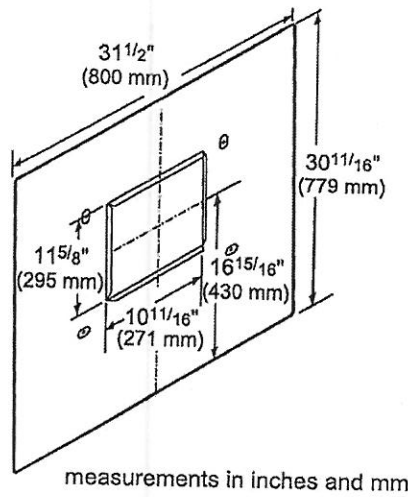

EXTNCB25W

For use with the following Inline and Remote Blowers: VTR630W, VTR1030W, VTR1330W, VTI610W, VTI1010W

OPTIONAL ACCESSORIES

REMOTE CONTROL PANEL  
 REMCPW



Convenience at your fingertips: The remote control accessory offers the freedom to extend your hood controls to a more reachable spot

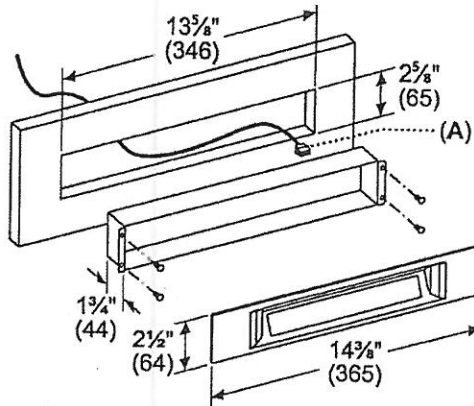

A: DBus Cable length: 30 feet (9180 mm)  
 measurements in inches (mm)

These warranties give you specific legal rights and you may have other rights that vary from state to state. Full warranty and limited warranty from date of installation. For complete warranty details, refer to your Use & Care manual, or ask your dealer.

Specifications are for planning purposes only. Refer to installation instructions and consult your countertop supplier prior to making counter opening. Consult with a heating and ventilation engineer for your specific ventilation requirements. For the most detailed information, refer to installation instructions accompanying product or write to Thermador indicating the model number. Specifications are correct at time of printing. Thermador reserves the right to change product specifications or design without notice. Some models are certified for use in Canada. Thermador is not responsible for products that are transported from the U.S. for use in Canada.

1 800 735 4328 | USA THERMADOR.COM | CANADA THERMADOR.CA | ©2020 BSH HOME APPLIANCES CORPORATION. ALL RIGHTS RESERVED.

PV-85  
 March 22, 2021

600 CFM Integral Blower

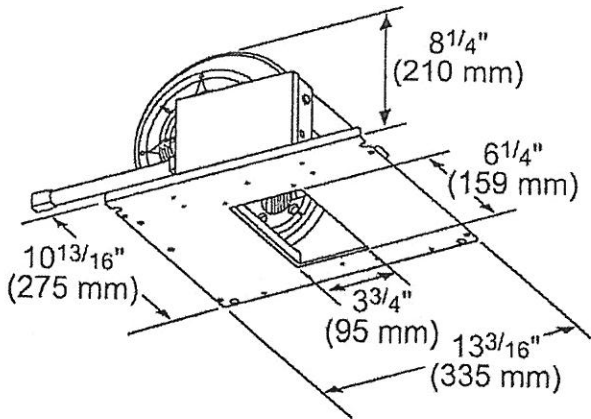

measurements in inches (mm)

Product Features

	Accessory
Brand	Thermador
SKU	VTN630W
Internal article number	VTN630W
EAN code	825225934738
Product packaging dimensions (HxWxD) (in)	12 1/8" x 13 3/8" x 19 7/8"
	11
	13
UPC code	825225934738
	MCSA02216228_i7490_1621980_VTN630W_PA

Technical Specification

Notes: Please refer to installation instructions. Installation instructions are available at [www.thermador.com](http://www.thermador.com). Specifications are correct at the time of printing. Thermador reserves the right to change product specifications and design at any time, without notice.

1 800 735 4328 | [WWW.THERMADOR.COM](http://WWW.THERMADOR.COM) | 1901 Main Street, Suite 600 Irvine, CA 92614

©2020 BSH HOME APPLIANCES CORPORATION, ALL RIGHTS RESERVED LITHO DATE: 09/2020