



ELEVATION 'A'

ELEVATION 'B'

ELEVATION 'C'

UNIT 4201 - 'THE MAPLEWOOD'

SB-12 ENERGY EFFICIENCY DESIGN MATRIX

PRESCRIPTIVE COMPLIANCE	SB-12 (SECTION 3.1.1) TABLE 3.1.1.2.A	
PACKAGE A1	SPACE HEATING FUEL	
	<input checked="" type="checkbox"/> GAS	<input type="checkbox"/> OIL
	<input type="checkbox"/> ELECTRIC	<input type="checkbox"/> PROPANE
	<input type="checkbox"/> EARTH	<input type="checkbox"/> SOLID FUEL

BUILDING COMPONENT	REQUIRED	PROPOSED
INSULATION RSI (R) VALUE		
CEILING W/ ATTIC SPACE	10.56 (R60)	10.56 (R60)
CEILING W/O ATTIC SPACE	5.46 (R31)	5.46 (R31)
EXPOSED FLOOR	5.46 (R31)	5.46 (R31)
WALLS ABOVE GRADE	3.87 (R22)	3.87 (R22)
BASEMENT WALLS	3.52 ci (R20 ci) *	3.52 ci (R20 ci) *
* PROPOSED VALUES MAY BE SUBSTITUTED W/ 2.11+1.76ci (R12+R10ci)		
BELOW GRADE SLAB ENTIRE SURFACE > 600mm BELOW GRADE	-	-
EDGE OF BELOW GRADE SLAB ≤ 600mm BELOW GRADE	1.76 (R10)	1.76 (R10)
HEATED SLAB OR SLAB ≤ 600mm BELOW GRADE	1.76 (R10)	1.76 (R10)
WINDOWS & DOORS		
WINDOWS/SLIDING GLASS DOORS (MAX U-VALUE)	1.6	1.6
SKYLIGHTS (MAX. U-VALUE)	2.8	2.8
APPLIANCE EFFICIENCY		
SPACE HEATING EQUIP. (AFUE%)	96%	96%
HRV EFFICIENCY (%)	75%	75%
DHW HEATER (EF)	0.8	0.8

- 1 - TITLE PAGE
- 2 - BASEMENT PLAN EL 'A'
- 3 - GROUND FLOOR PLAN EL 'A'
- 4 - LOFT FLOOR PLAN EL 'A'
- 5 - PARTIAL FLOOR PLANS, EL. 'B'
- 6 - PARTIAL FLOOR PLANS, EL. 'C'
- 7 - FRONT ELEVATION EL 'A'
- 8 - LEFT SIDE ELEVATION EL 'A'
- 9 - RIGHT SIDE ELEVATION EL 'A'
- 10 - FRONT ELEVATION EL 'B'
- 11 - LEFT SIDE ELEVATION EL 'B'
- 12 - RIGHT SIDE ELEVATION EL 'B'
- 13 - FRONT ELEVATION EL 'C'
- 14 - LEFT SIDE ELEVATION EL 'C'
- 15 - RIGHT SIDE ELEVATION EL 'C'
- 16 - REAR ELEVATION 'A', 'B' & 'C'
- 17 - CROSS SECTION 'A-A' & DETAILS
- 18 - CONSTRUCTION NOTES
- W1 - DECK CONDITIONS
- W2 - DECK CONDITIONS
- W3 - DECK DETAILS

AREA CALCULATIONS	EL. 'A'	EL. 'B'	EL. 'C'									
GROUND FLOOR AREA	1866 sq. ft. (175.22 sq. m.)	1866 sq. ft. (175.22 sq. m.)	1895 sq. ft. (176.05 sq. m.)									
SECOND FLOOR AREA	1678 sq. ft. (155.89 sq. m.)	1637 sq. ft. (152.08 sq. m.)	1745 sq. ft. (162.12 sq. m.)									
SUBTOTAL	3564 sq. ft. (331.11 sq. m.)	3523 sq. ft. (327.30 sq. m.)	3640 sq. ft. (338.17 sq. m.)									
DEDUCT ALL OPEN AREAS	841 sq. ft. (78.13 sq. m.)	841 sq. ft. (78.13 sq. m.)	634 sq. ft. (58.90 sq. m.)									
TOTAL NET AREA	2723 sq. ft. (252.97 sq. m.)	2682 sq. ft. (249.17 sq. m.)	3006 sq. ft. (279.27 sq. m.)									
FINISHED BASEMENT AREA	131 sq. ft. (12.17 sq. m.)	131 sq. ft. (12.17 sq. m.)	182 sq. ft. (16.91 sq. m.)									
COVERAGE W/O PORCH	2285 sq. ft. (212.28 sq. m.)	2285 sq. ft. (212.28 sq. m.)	2294 sq. ft. (213.12 sq. m.)									
COVERAGE W/ PORCH	2343 sq. ft. (217.67 sq. m.)	2341 sq. ft. (217.49 sq. m.)	2349 sq. ft. (218.23 sq. m.)									
COVERAGE W/ OPT. LOGGIA	2533 sq. ft. (235.32 sq. m.)	2531 sq. ft. (235.14 sq. m.)	2551 sq. ft. (237.00 sq. m.)									
WINDOW / WALL AREA CALCULATIONS	EL. 'A'	EL. 'B'	EL. 'C'	EL. 'A'	EL. 'A'	EL. 'A'	EL. 'B'	EL. 'B'	EL. 'B'	EL. 'C'	EL. 'C'	EL. 'C'
	STD. PLAN	STD. PLAN	STD. PLAN	WOD	LOD	WOB	WOD	LOD	WOB	WOD	LOD	WOB
GROSS WALL AREA	4221 sq. ft. (392.14 sq. m.)	4221 sq. ft. (392.14 sq. m.)	4221 sq. ft. (392.14 sq. m.)	4290 sq. ft. (398.55 sq. m.)	4343 sq. ft. (403.48 sq. m.)	4513 sq. ft. (419.27 sq. m.)	4290 sq. ft. (398.55 sq. m.)	4343 sq. ft. (403.48 sq. m.)	4513 sq. ft. (419.27 sq. m.)	4290 sq. ft. (398.55 sq. m.)	4343 sq. ft. (403.48 sq. m.)	4513 sq. ft. (419.27 sq. m.)
GROSS WINDOW AREA INCL. GLASS DOORS & SKYLIGHTS	375 sq. ft. (34.84 sq. m.)	357 sq. ft. (33.17 sq. m.)	478 sq. ft. (44.41 sq. m.)	377 sq. ft. (35.02 sq. m.)	400 sq. ft. (37.16 sq. m.)	438 sq. ft. (40.69 sq. m.)	358 sq. ft. (33.26 sq. m.)	382 sq. ft. (35.49 sq. m.)	419 sq. ft. (38.93 sq. m.)	480 sq. ft. (44.59 sq. m.)	503 sq. ft. (46.73 sq. m.)	540 sq. ft. (50.17 sq. m.)
TOTAL WINDOW %	8.88 %	8.46 %	11.32 %	8.79 %	9.21 %	9.71 %	8.34 %	8.80 %	9.28 %	11.19 %	11.58 %	11.97 %

7. -	-	-
6. -	-	-
5. -	-	-
4. ISSUED FOR PERMIT	-	-
3. REVISED PER STRUC. ENG. COMMENTS	2022.08.05	WT
2. REV. AS PER FLOOR, ROOF LAYOUTS	2022.05.19	SP
1. ADDED ELEVATION 'C' & STD. 9 FT. BASEMENT	2022.02.11	WT
REVISIONS	DATE (YYYYMMDD)	BY



FOR STRUCTURAL ONLY. EXCLUDING
ENGINEERED ROOF TRUSS, FLOOR
JOIST, AND FLOOR LVL BEAM DESIGN.

WSP
150 BURNHAMTHORPE RD. UNIT 101
THORNHILL, ONTARIO M3H 1T4
TEL: 905.882.4211 FAX: 905.882.2058 WWW.WSPGROUP.CA

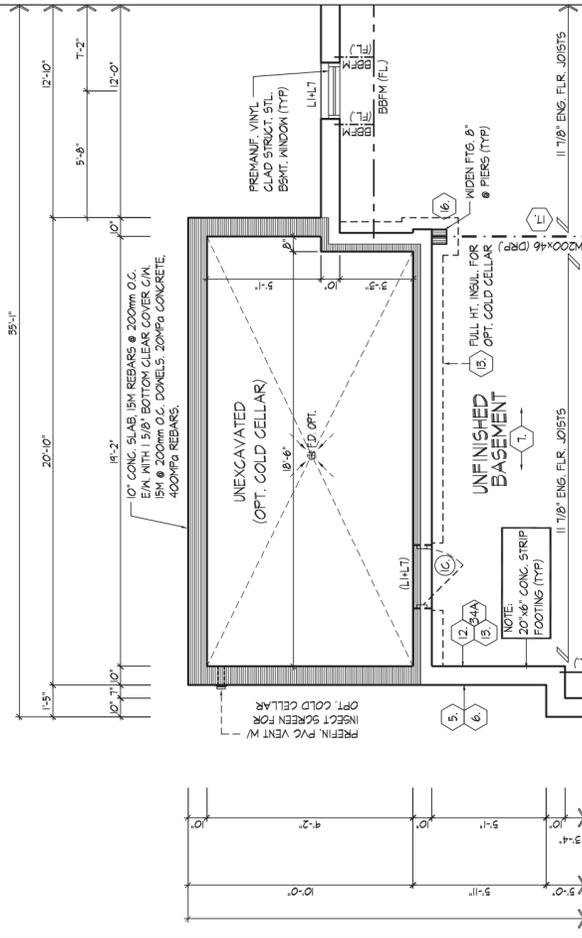

PART. BASEMENT PLAN EL. 'A'
OPT. LOGGIA CONDITION (ELEV. 'B' & 'C' SIMILAR)

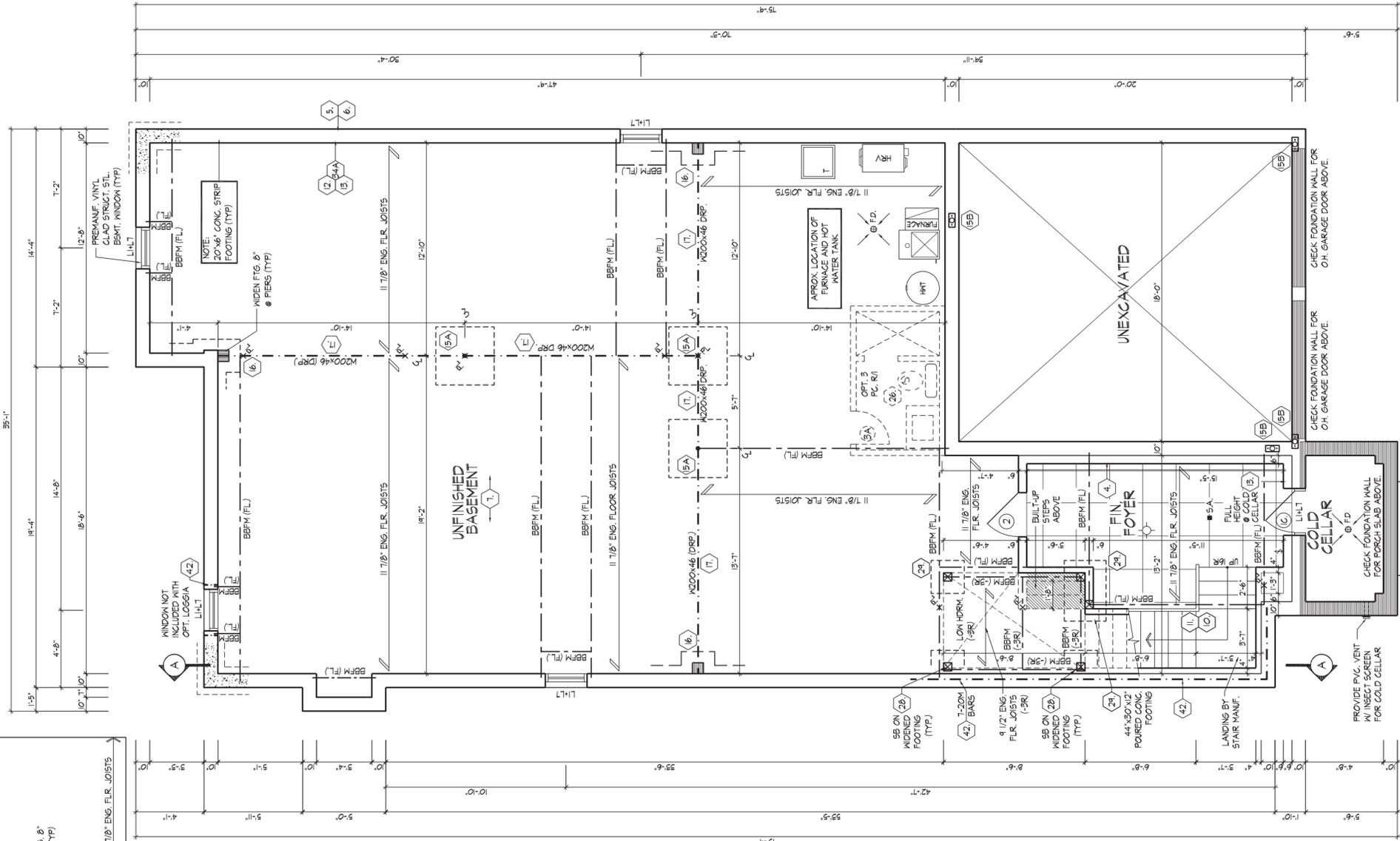

PROVIDE SOLID MOOD BLOCKING @
24" O.C. FOR FIRST JOIST SPAN
WHEN PARALLEL W/ EXTERIOR WALL

REFER TO FLOOR JOIST
MANUFACTURER'S DRAWINGS FOR
LAYOUT, SPACING, BLOCKING &
STRAPPING REQUIREMENTS.
INSTALLATION DETAILS AND HANGER
SIZES & SHELF-LOOK THICKNESS

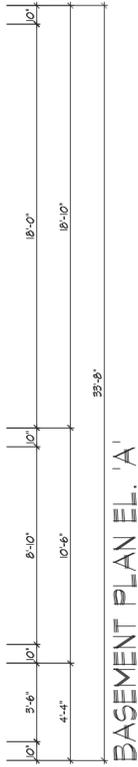

BASEMENT PLAN EL. 'A'

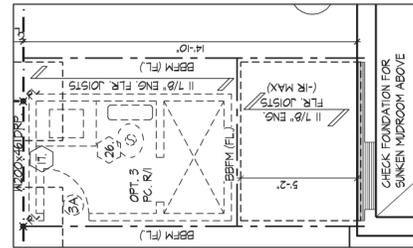

PART. BASEMENT PLAN
SUNKEN MUDROOM COND.
(-1R MAX)

It is the builder's complete responsibility to ensure that all plans submitted for approval fully comply with the Architectural Guidelines and all applicable regulations and requirements including zoning provisions and any provisions in the subdivision agreement. The Control Architect is not responsible in any way for examining or approving site (lotting) plans or working drawings with respect to any zoning or building code or permit matter or that any house can be properly built or located on its lot.

This is to certify that these plans comply with the applicable Architectural Design Guidelines approved by the City of VAUGHAN.



THE UNDERSIGNED HAS REVIEWED AND TAKES RESPONSIBILITY FOR THIS DESIGN AND HAS THE QUALIFICATIONS AND MEETS THE REQUIREMENTS SET OUT IN THE ONTARIO BUILDING CODE TO BE A DESIGNER.

QUALIFICATION INFORMATION
Allan Whiting *AW* 23177
SIGNATURE BCIN
REGISTRATION INFORMATION
HUNT DESIGN ASSOCIATES INC. 19695



GOLDPARK HOMES - 221081
PINE VALLEY PH. 2, VAUGHAN, ONT.

Drawn By: JB
Checked By: VS
Scale: 3/16"=1'-0"

BASEMENT PLAN EL. 'A'
UNIT 4201 - THE MAPLEWOOD
REV.2022.08.05

File Number: 217020WS4201
Page Number: 2 of 17

All drawings specifications related documents and design are the copyright property of Hunt Design Associates (H.D.A.). Reproduction of this property in whole or in part is strictly prohibited without H.D.A.'s written permission. H.D.A. assumes no responsibility or liability for this property unless it bears the appropriate BCIN number and original signature.



FOR STRUCTURAL ONLY. EXCLUDING
ENGINEERED ROOF TRUSS, FLOOR
JOIST, AND FLOOR LVL BEAM DESIGN.

WSP
150 DUNDAS ST. W. TORONTO, ONT. M5G 1C4
TEL: 416-593-8242 FAX: 416-593-8200 WWW.WSPGROUP.COM

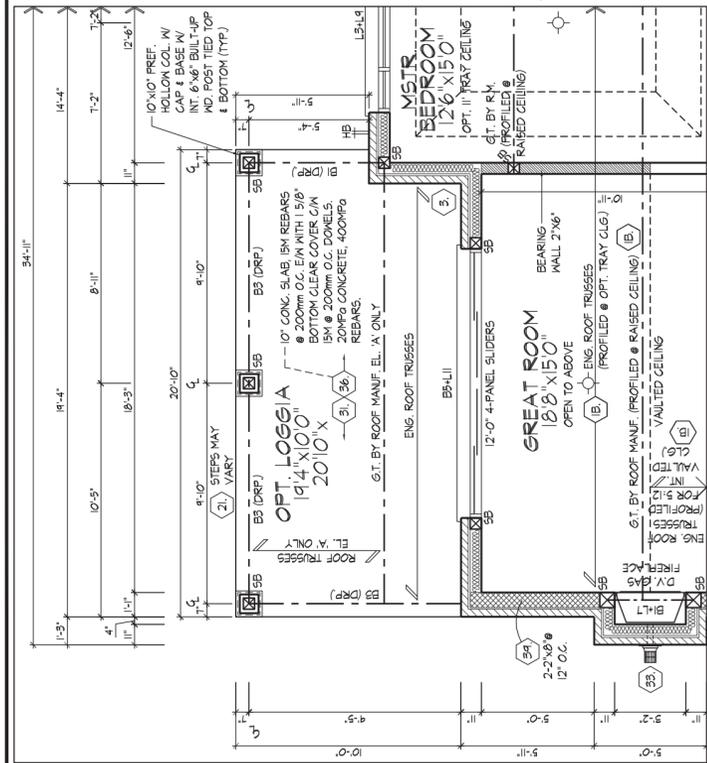

PART. GROUND FLOOR PLAN EL. 'A'
OPT. LOGGIA CONDITION (ELEV. 'B' SIMILAR)

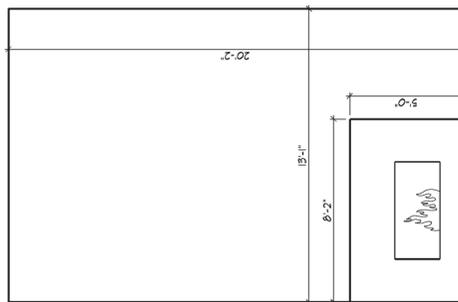

'A' DBL. SIDED FIRE PLACE

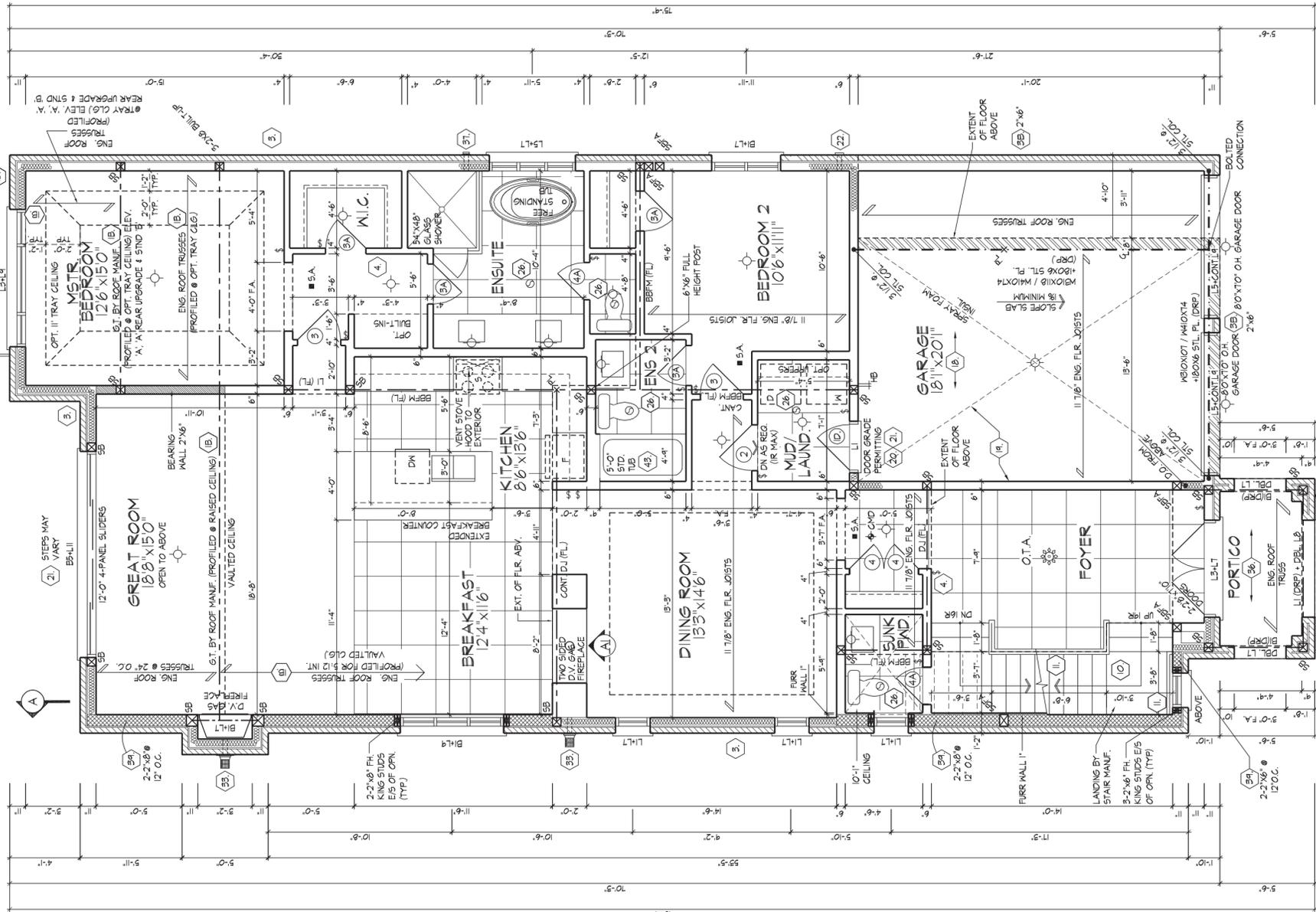

GROUND FLOOR PLAN EL. 'A'

- PROVIDE SOLID WOOD BLOCKING @ 24\"/>
- REFER TO FLOOR JOIST MANUFACTURER'S DRAWINGS FOR LAYOUT, SPACING, BLOCKING & STRAPPING REQUIREMENTS. INSTALLATION DETAILS AND HANGER SIZES. 1\"/>
- REFER TO ROOF TRUSS MANUFACTURER'S DRAWINGS FOR LAYOUT, SPACING, INSTALLATION DETAILS AND HANGER SIZES.

It is the builder's complete responsibility to ensure that all plans submitted for approval fully comply with the Architectural Guidelines and all applicable regulations and requirements including zoning provisions and any provisions in the subdivision agreement. The Control Architect is not responsible in any way for examining or approving site (lotting) plans or working drawings with respect to any zoning or building code or permit matter or that any house can be properly built or located on its lot.

This is to certify that these plans comply with the applicable Architectural Design Guidelines approved by the City of VAUGHAN.



THE UNDERSIGNED HAS REVIEWED AND TAKES RESPONSIBILITY FOR THIS DESIGN AND HAS THE QUALIFICATIONS AND MEETS THE REQUIREMENTS SET OUT IN THE ONTARIO BUILDING CODE TO BE A DESIGNER.
 QUALIFICATION INFORMATION
 Allan Whiting
 REGISTRATION INFORMATION
 HUNT DESIGN ASSOCIATES INC. 19695



GOLDPARK HOMES - 221081
 PINE VALLEY PH. 2, VAUGHAN, ONT.
 UNIT 4201 - THE MAPLEWOOD
 REV.2022.08.05
 Drawn By: JB, Checked By: VS, Scale: 3/16"=1'-0", File Number: 217020WS4201, Page Number: 3 of 17



WSP
 100 BROADVIEW AVE. SUITE 101
 THORNHILL, ONTARIO M2W 1G1
 TEL: 905.882.4211 FAX: 905.882.2208 WWW.WSPORP.COM

FOR STRUCTURAL ONLY. EXCLUDING
 ENGINEERED ROOF TRUSSES, FLOOR
 JOIST, AND FLOOR LVL BEAM DESIGN.

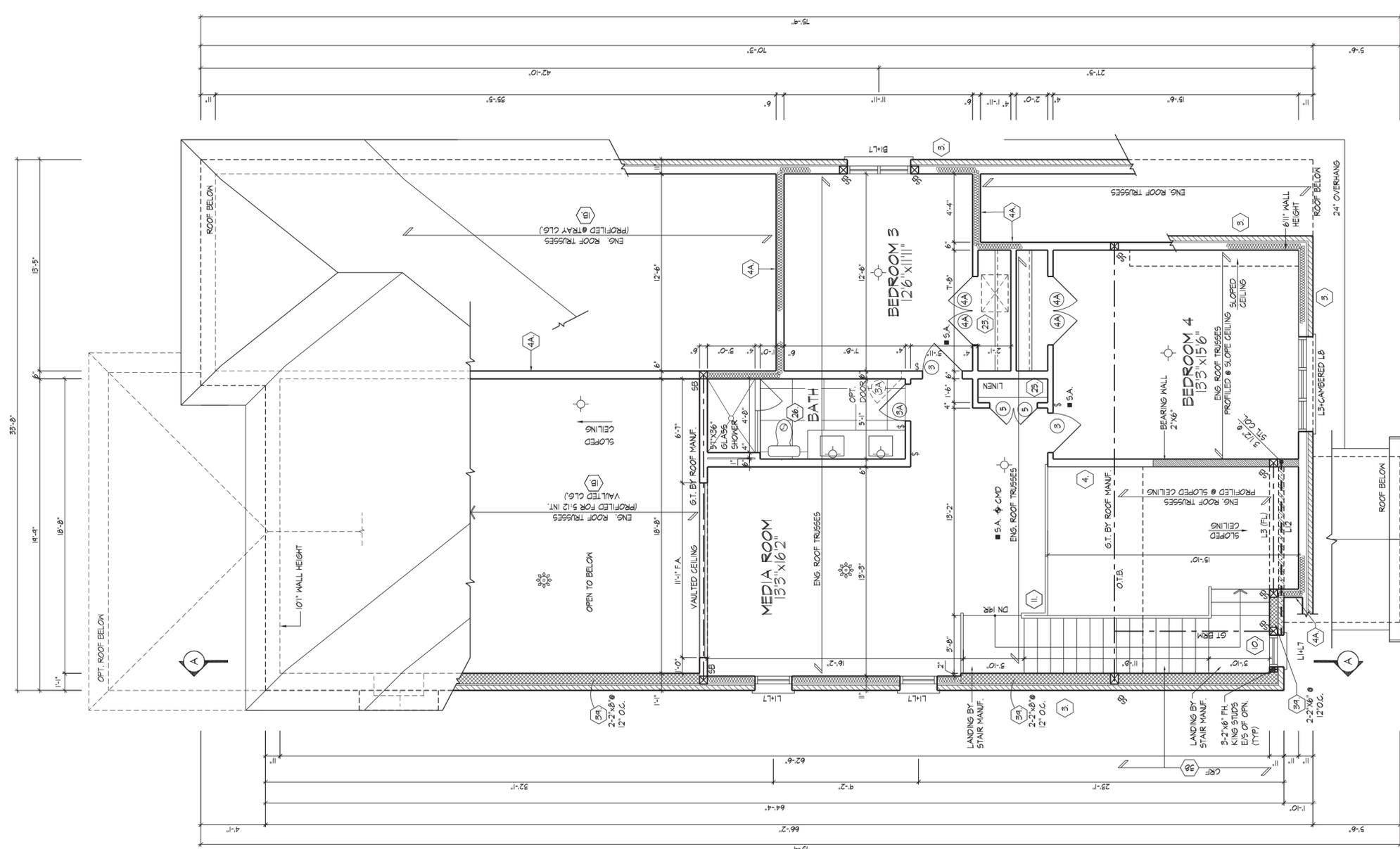

REFER TO ROOF TRUSSES FOR
 MANUFACTURING DETAILS FOR
 LAYOUT OF CEILING INSULATION
 DETAILS AND HANGER SIZES.

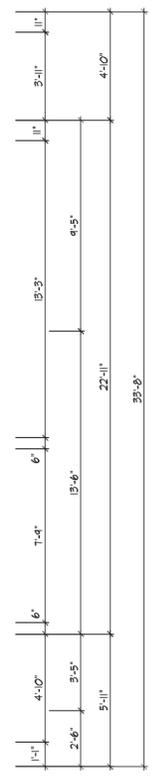

LOFT FLOOR PLAN EL. 'A'

It is the builder's complete responsibility to ensure that all plans submitted for approval fully comply with the Architectural Guidelines and all applicable regulations and requirements including zoning provisions and any provisions in the subdivision agreement. The Control Architect is not responsible in any way for examining or approving site (lotting) plans or working drawings with respect to any zoning or building code or permit matter or that any house can be properly built or located on its lot.

This is to certify that these plans comply with the applicable Architectural Design Guidelines approved by the City of VAUGHAN.

JOHN G. WILLIAMS LTD., ARCHITECT
 ARCHITECTURAL CONTROL REVIEW
 AND APPROVAL
 APPROVED BY: [Signature]
 DATE: AUG 08, 2022
 This stamp certifies compliance with the applicable Design Guidelines only and bears no further professional responsibility.

THE UNDERSIGNED HAS REVIEWED AND TAKES RESPONSIBILITY FOR THIS DESIGN AND HAS THE QUALIFICATIONS AND MEETS THE REQUIREMENTS SET OUT IN THE ONTARIO BUILDING CODE TO BE A DESIGNER.
 QUALIFICATION INFORMATION:
 Allan Whiting aw 23177
 HUNT DESIGN ASSOCIATES INC. 19695



GOLDPARK HOMES - 221081
 PINE VALLEY PH. 2, VAUGHAN, ONT.
 UNIT 4201 - THE MAPLEWOOD
 REV.2022.08.05
 Drawn By: JB VS 3/16"=1'-0"
 Checked By: VS
 Scale: 3/16"=1'-0"
 File Number: 217020WS4201
 Page Number: 4 of 17

All drawings specifications related documents and design are the copyright property of Hunt Design Associates (H.D.A.). Reproduction of this property in whole or in part is strictly prohibited without H.D.A.'s written permission. H.D.A. assumes no responsibility or liability for this property unless it bears the appropriate BCIN number and original signature.



FOR STRUCTURAL ONLY. EXCLUDING
ENGINEERED ROOF TRUSS, FLOOR
JOIST, AND FLOOR LVL BEAM DESIGN.

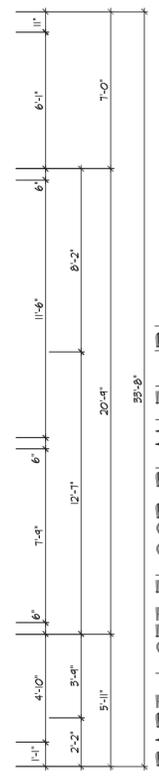
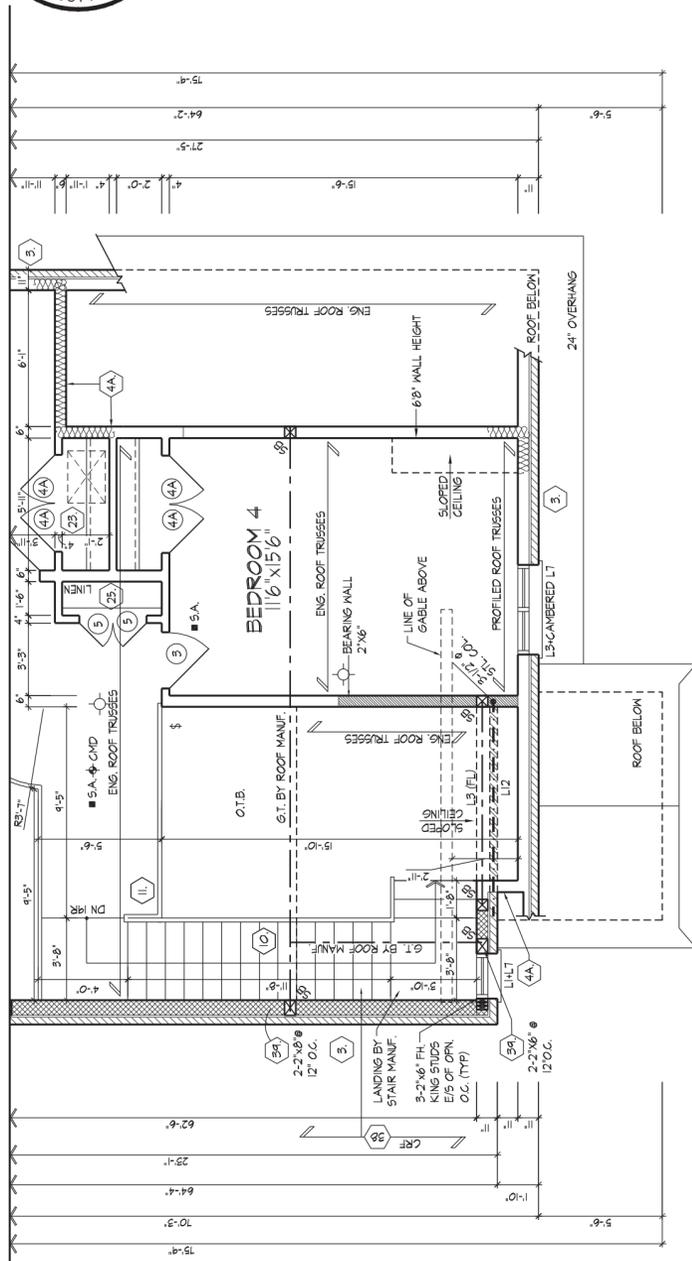

PART. LOFT FLOOR PLAN EL. 'B'

REFER TO ROOF TRUSS
MANUFACTURER'S DRAWINGS FOR
LAYOUT, SPACING, INSTALLATION
DETAILS AND HANGER SIZES.

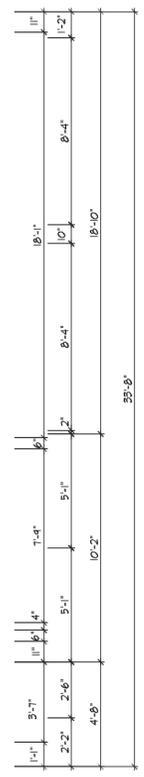
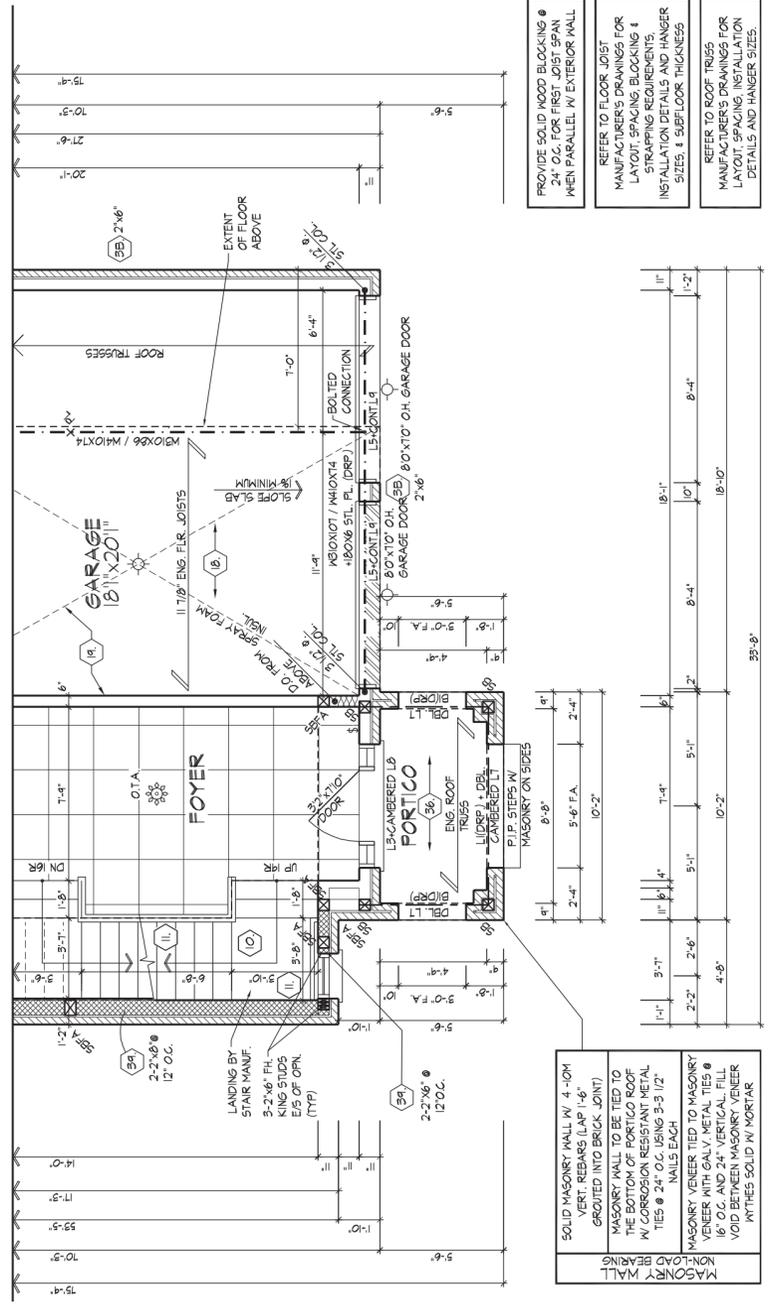

PART. GROUND FLOOR PLAN EL. 'B'

PROVIDE SOLID WOOD BLOCKING @
24" O.C. FOR FIRST JOIST SPAN
WHEN PARALLEL W/ EXTERIOR WALL.

REFER TO FLOOR JOIST
MANUFACTURER'S DRAWINGS FOR
LAYOUT, SPACING, BLOCKING &
STRAPPING REQUIREMENTS.
INSTALLATION DETAILS AND HANGER
SIZES, & SUBFLOOR THICKNESS.

REFER TO ROOF TRUSS
MANUFACTURER'S DRAWINGS FOR
LAYOUT, SPACING, INSTALLATION
DETAILS AND HANGER SIZES.

NON-LOAD BEARING
MASONRY WALL
SOLID MASONRY WALL W/ 4" ON
VERT. REBARS (LAP 1'-6")
GROUTED INTO BRICK JOINT
MASONRY WALL TO BE TIED TO
THE BOTTOM OF PORTICO ROOF
W/ CORROSION RESISTANT METAL
TIES @ 24" O.C. USING 3/3 1/2"
NAILS EACH
MASONRY VENEER TIED TO MASONRY
W/ GALV. METAL TIES @
16" O.C. AND 24" VERTICAL. FILL
VOID BETWEEN MASONRY VENEER
WITHES SOLID W/ MORTAR

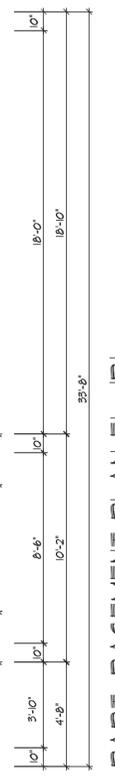
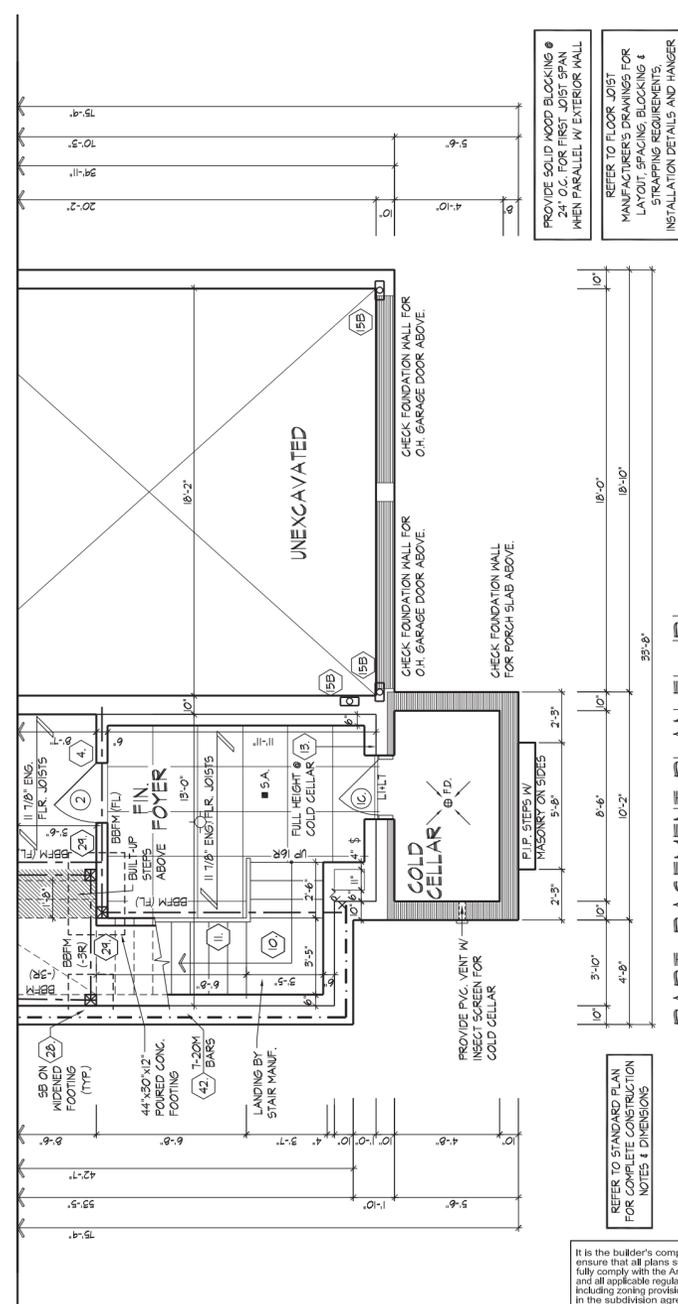

PART. BASEMENT PLAN EL. 'B'

PROVIDE SOLID WOOD BLOCKING @
24" O.C. FOR FIRST JOIST SPAN
WHEN PARALLEL W/ EXTERIOR WALL.

REFER TO FLOOR JOIST
MANUFACTURER'S DRAWINGS FOR
LAYOUT, SPACING, BLOCKING &
STRAPPING REQUIREMENTS.
INSTALLATION DETAILS AND HANGER
SIZES, & SUBFLOOR THICKNESS.

REFER TO STANDARD PLAN
FOR COMPLETE CONSTRUCTION
NOTES & DIMENSIONS

It is the builder's complete responsibility to ensure that all plans submitted for approval fully comply with the Architectural Guidelines and all applicable regulations and requirements including zoning provisions and any provisions in the subdivision agreement. The Control Architect is not responsible in any way for examining or approving site (lotting) plans or working drawings with respect to any zoning or building code or permit matter or that any house can be properly built or located on its lot.

This is to certify that these plans comply with the applicable Architectural Design Guidelines approved by the City of VAUGHAN.



THE UNDERSIGNED HAS REVIEWED AND TAKES RESPONSIBILITY FOR THIS DESIGN AND HAS THE QUALIFICATIONS AND MEETS THE REQUIREMENTS SET OUT IN THE ONTARIO BUILDING CODE TO BE A DESIGNER.
QUALIFICATION INFORMATION
Allan Whiting
Signature: [Signature]
Registration Information: BCON
HUNT DESIGN ASSOCIATES INC. 19695



GOLDPARK HOMES - 221081
PINE VALLEY PH. 2, VAUGHAN, ONT.
REV.2022.08.05

PARTIAL FLOOR PLANS, EL. 'B'
UNIT 4201 - THE MAPLEWOOD

Drawn By: JB
Checked By: VS
Scale: 3/16"=1'-0"
File Number: 217020WS4201
Page Number: 5 of 17

8966 Woodbine Ave., Markham, ON L3R 0J7 T 905.737.5133 F 905.737.7326



FOR STRUCTURAL ONLY. EXCLUDING
ENGINEERED ROOF TRUSS, FLOOR
JOIST, AND FLOOR LVL BEAM DESIGN.

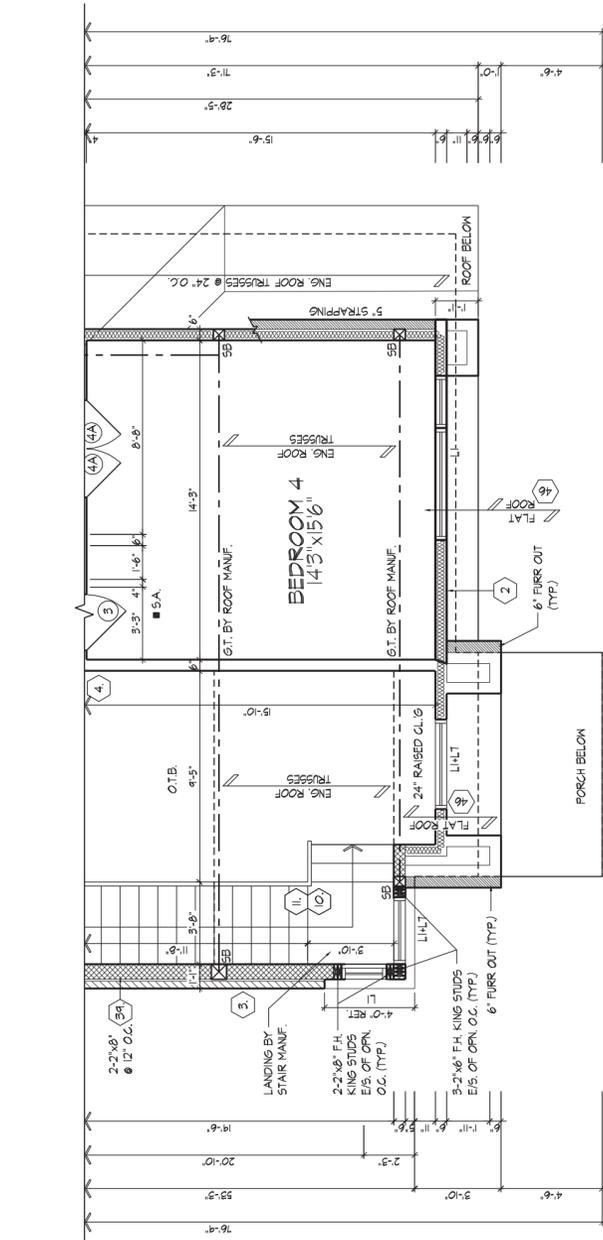

REFER TO ROOF TRUSS
MANUFACTURER'S DRAWINGS FOR
LAYOUT, SPACING, INSTALLATION
DETAILS AND HANGER SIZES.

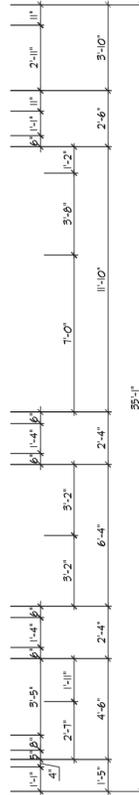

PARTIAL SECOND FLOOR PLAN, EL. 'C'

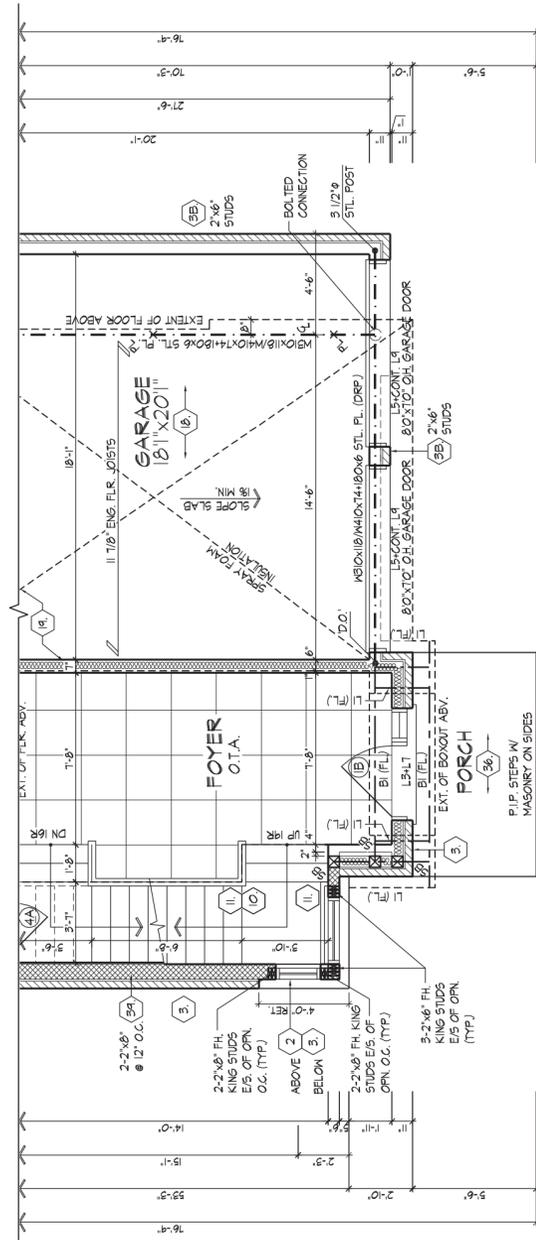

PROVIDE SOLID WOOD BLOCKING @
24" O.C. FOR FIRST JOIST SPAN
WHEN PARALLEL W/ EXTERIOR WALL.

REFER TO FLOOR JOIST
MANUFACTURER'S DRAWINGS FOR
LAYOUT, SPACING, BLOCKING &
STRAPPING REQUIREMENTS.
INSTALLATION DETAILS AND HANGER
SIZES & SUBFLOOR THICKNESS.

REFER TO ROOF TRUSS
MANUFACTURER'S DRAWINGS FOR
LAYOUT, SPACING, INSTALLATION
DETAILS AND HANGER SIZES.

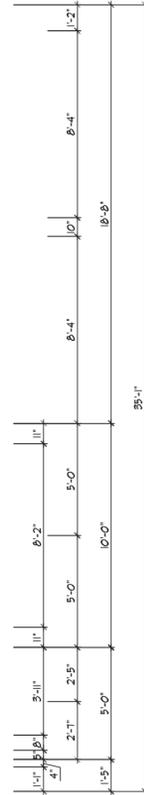

PARTIAL GROUND FLOOR PLAN, EL. 'C'

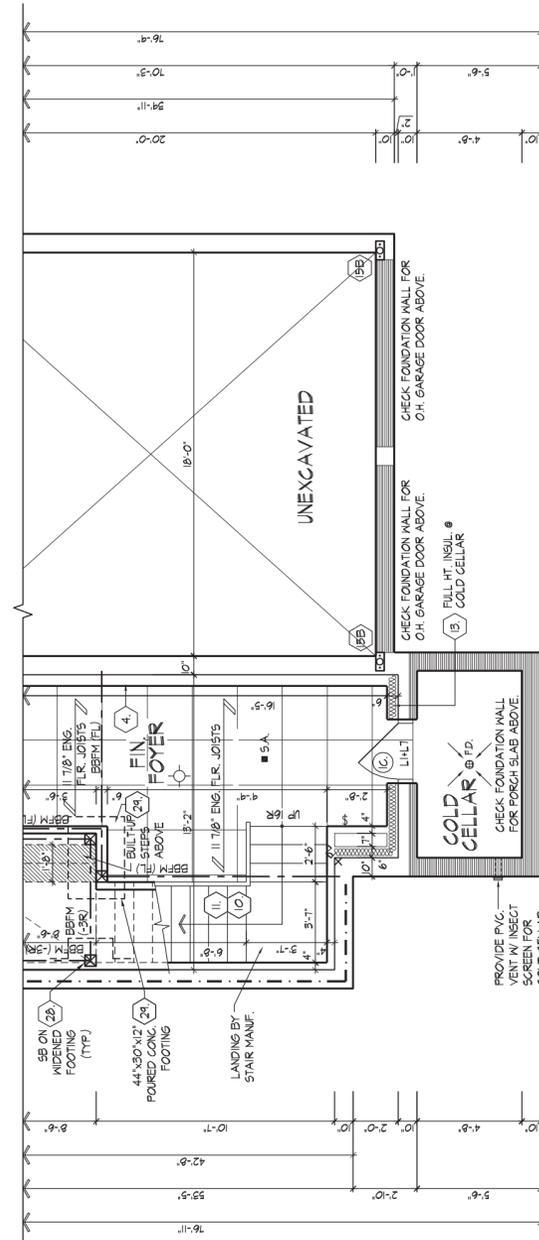

PROVIDE SOLID WOOD BLOCKING @
24" O.C. FOR FIRST JOIST SPAN
WHEN PARALLEL W/ EXTERIOR WALL.

REFER TO FLOOR JOIST
MANUFACTURER'S DRAWINGS FOR
LAYOUT, SPACING, BLOCKING &
STRAPPING REQUIREMENTS.
INSTALLATION DETAILS AND HANGER
SIZES & SUBFLOOR THICKNESS.



PARTIAL BASEMENT PLAN, EL. 'C'

It is the builder's complete responsibility to ensure that all plans submitted for approval fully comply with the Architectural Guidelines and all applicable regulations and requirements including zoning provisions and any provisions in the subdivision agreement. The Control Architect is not responsible in any way for examining or approving site (lot) plans or working drawings with respect to any zoning or building code or permit matter or that any house can be properly built or located on its lot.

This is to certify that these plans comply with the applicable Architectural Design Guidelines approved by the City of VAUGHAN.

JOHN G. WILLIAMS LTD., ARCHITECT
ARCHITECTURAL CONTROL REVIEW
AND APPROVAL

APPROVED BY: [Signature]
DATE: AUG 06, 2022

This stamp certifies compliance with the applicable Design Guidelines only and bears no further professional responsibility.

THE UNDERSIGNED HAS REVIEWED AND TAKES RESPONSIBILITY FOR THIS DESIGN AND HAS THE QUALIFICATIONS AND MEETS THE REQUIREMENTS SET OUT IN THE ONTARIO BUILDING CODE TO BE A DESIGNER.

QUALIFICATION INFORMATION
Allan Whiting [Signature] 23177

REGISTRATION INFORMATION
SIGNATURE BCIN
HUNT DESIGN ASSOCIATES INC. 19695

HUNT
DESIGN ASSOCIATES INC.
www.hunt-design.ca

GOLDPARK HOMES - 221081
PINE VALLEY PH. 2, VAUGHAN, ONT.

PARTIAL FLOOR PLANS, EL. 'C'
UNIT 4201 - THE MAPLEWOOD
REV.2022.08.05

Drawn By: WT
Checked By: VS
Scale: 3/16"=1'-0"
File Number: 217020WS4201
Page Number: 6 of 17

All drawings specifications related documents and design are the copyright property of Hunt Design Associates (H.D.A.). Reproduction of this property in whole or in part is strictly prohibited without H.D.A.'s written permission. H.D.A. assumes no responsibility or liability for this property unless it bears the appropriate BCIN number and original signature.

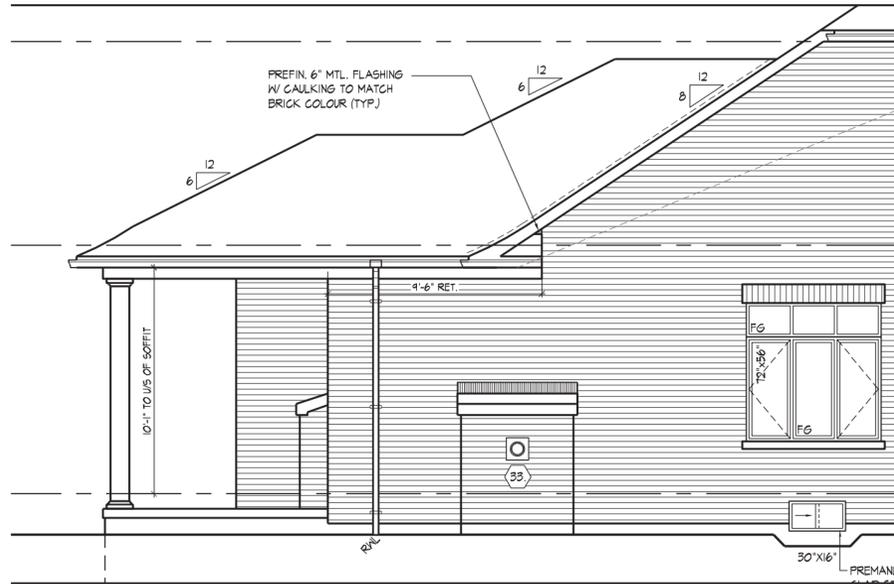

PART. LEFT SIDE ELEVATION 'A' W/ OPT. LOGGIA

REFER TO FRONT ELEVATION FOR TYPICAL NOTES & INFORMATION

ROOF OVERHANGS TO BE 15' UNLESS NOTED OTHERWISE

WINDOW SUMMARY			
PER O.B.C. TABLE 9.10.15.4			
LEFT SIDE ELEVATION A			
QUAN.	WIDTH	DEPTH	WINDOW / DOOR FRAME SIZE (S.F.)
1	30"	16"	2.17
1	72"	56"	24.56
1	72"	20"	7.56
2	24"	56"	14.44
2	24"	20"	4.44
1	24"	40"	5.00
2	24"	44"	11.11
0	0"	0"	0.00
0	0"	0"	0.00
0	0"	0"	0.00
0	ARCH	0.00	0.00
0	ARCH	0.00	0.00
0	ARCH	0.00	0.00
0	ARCH	0.00	0.00
SPATIAL CALCULATION			
EXPOSING BUILDING FACE AREA	117.30	S.M.	
PORTION WALL AREA	117.30	S.M.	
LIMITING DISTANCE	7	1.2 m	
MAX. % OPENINGS	7	1.4 %	
OPENINGS ALLOWED	88.38	S.F.	
OPENINGS PROVIDED	89.28	S.F.	
ADDITIONAL NOTES			
GLAZED AREA CALCULATED W/ FRAME SIZE MINUS 2" AROUND ENTIRE PERIMETER			

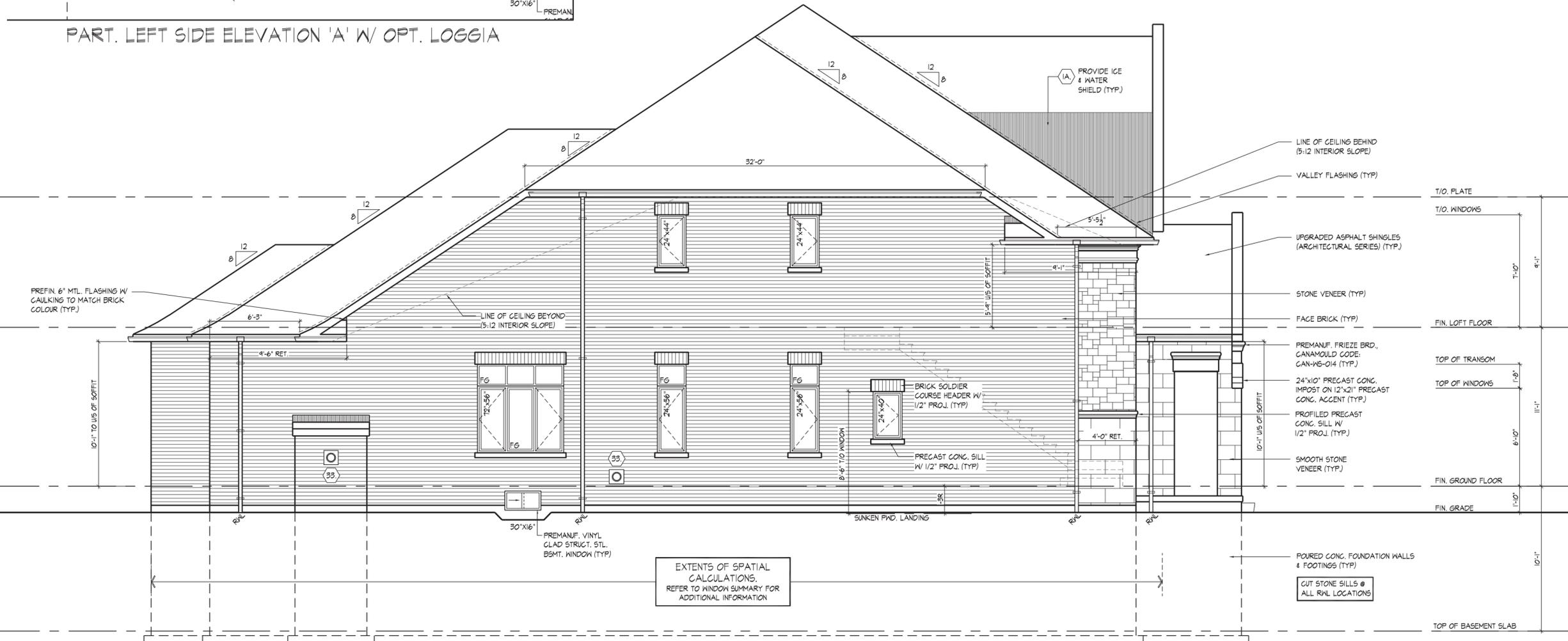

LEFT SIDE ELEVATION 'A'

EXTENTS OF SPATIAL CALCULATIONS. REFER TO WINDOW SUMMARY FOR ADDITIONAL INFORMATION

CUT STONE SILLS @ ALL RNL LOCATIONS

It is the builder's complete responsibility to ensure that all plans submitted for approval fully comply with the Architectural Guidelines and all applicable regulations and requirements including zoning provisions and any provisions in the subdivision agreement. The Control Architect is not responsible in any way for examining or approving site (lotting) plans or working drawings with respect to any zoning or building code or permit matter or that any house can be properly built or located on its lot.

This is to certify that these plans comply with the applicable Architectural Design Guidelines approved by the City of VAUGHAN.

JOHN G. WILLIAMS LTD., ARCHITECT
ARCHITECTURAL CONTROL REVIEW AND APPROVAL

APPROVED BY: *[Signature]*
DATE: AUG 16, 2022

This stamp certifies compliance with the applicable Design Guidelines only and bears no further professional responsibility.

THE UNDERSIGNED HAS REVIEWED AND TAKES RESPONSIBILITY FOR THIS DESIGN AND HAS THE QUALIFICATIONS AND MEETS THE REQUIREMENTS SET OUT IN THE ONTARIO BUILDING CODE TO BE A DESIGNER.

QUALIFICATION INFORMATION
Name: Allan Whiting
Signature: *[Signature]*
BCIN: 23177

DATE: 08/16/2022

REGISTRATION INFORMATION
Name: HUNT DESIGN ASSOCIATES INC.
BCIN: 19695

Scale: 3/16"=1'-0"

File Number: 217020WS4201

Page Number: 8 of 17

8966 Woodbine Ave., Markham, ON L3R 0J7 T 905.737.5133 F 905.737.7326

www.huntdesign.ca

HUNT DESIGN ASSOCIATES INC.

GOLDPARK HOMES - 221081
PINE VALLEY PH. 2, VAUGHAN, ONT.
REV.2022.08.05

LEFT SIDE ELEVATION EL 'A'
UNIT 4201 - THE MAPLEWOOD

W/TANG / FRI AUG 5 2022 11:16 PM / I:\PROJECTS\2021\221081.GOLDPARKHOMES\4201\WS4201-MAPLEWOOD.DWG

ROOF OVERHANGS TO BE 15" UNLESS NOTED OTHERWISE

ROOF PLAN 'B' W/ OPT. LOGGIA N.T.S.

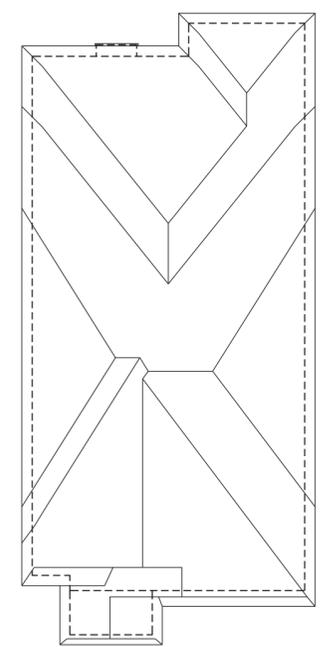
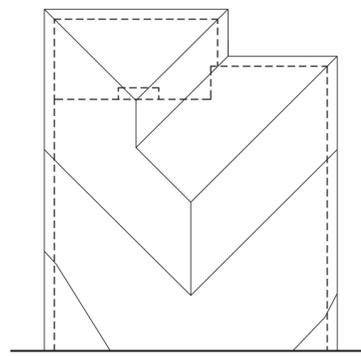

ROOF PLAN 'B' N.T.S.

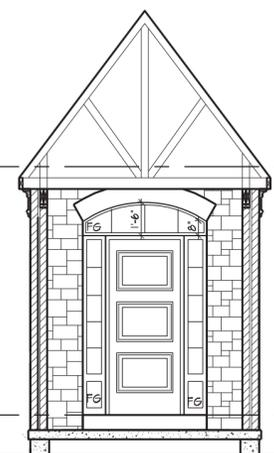

INTERIOR PORTICO EL. 'B'

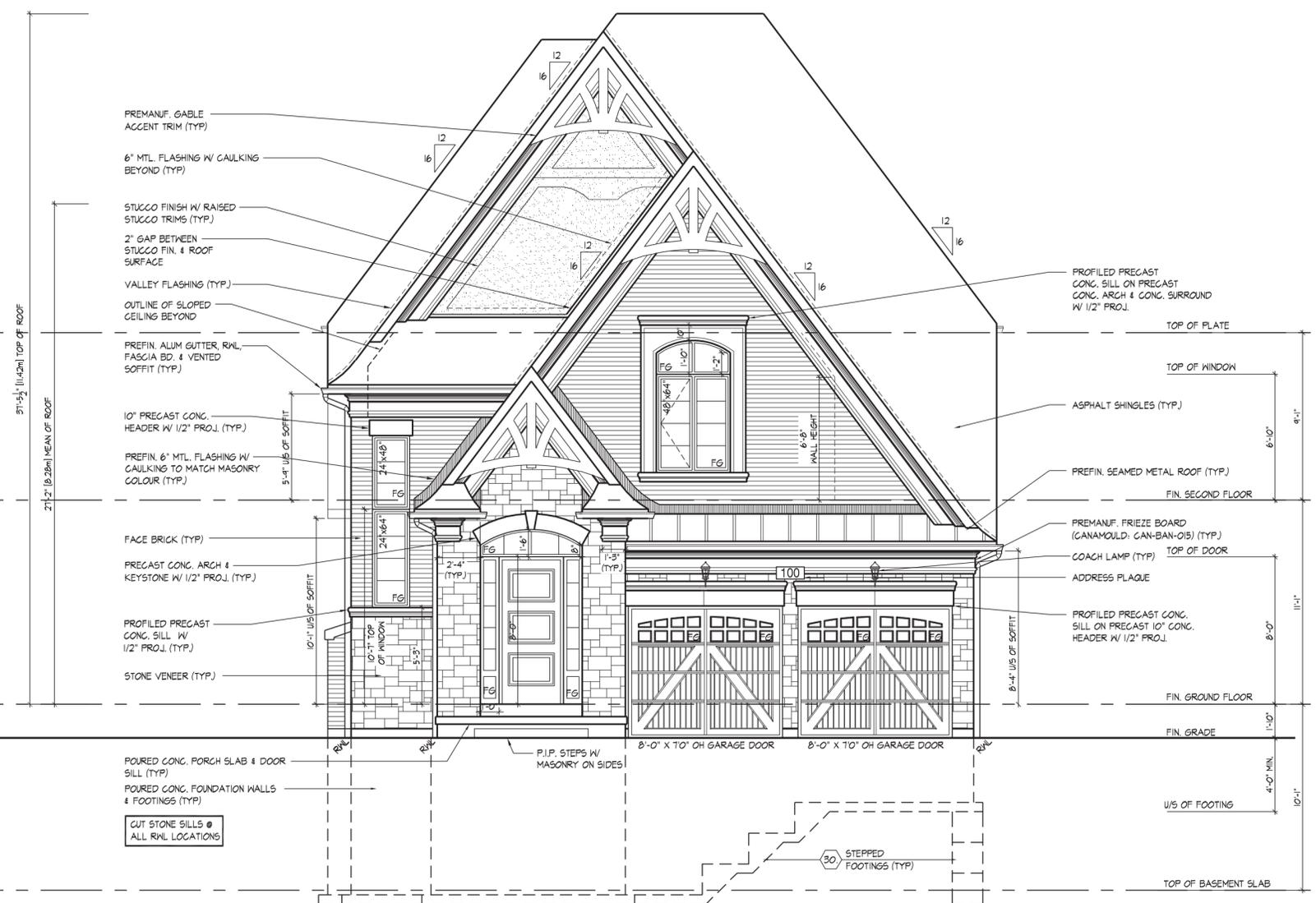

FRONT ELEVATION 'B'

It is the builder's complete responsibility to ensure that all plans submitted for approval fully comply with the Architectural Guidelines and all applicable regulations and requirements including zoning provisions and any provisions in the subdivision agreement. The Control Architect is not responsible in any way for examining or approving site (lotting) plans or working drawings with respect to any zoning or building code or permit matter or that any house can be properly built or located on its lot.

This is to certify that these plans comply with the applicable Architectural Design Guidelines approved by the City of VAUGHAN.

JOHN G. WILLIAMS LTD., ARCHITECT
 ARCHITECTURAL CONTROL REVIEW
 AND APPROVAL

APPROVED BY:

DATE: AUG 08 2022

This stamp certifies compliance with the applicable Design Guidelines only and bears no further professional responsibility.

THE UNDERSIGNED HAS REVIEWED AND TAKES RESPONSIBILITY FOR THIS DESIGN AND HAS THE QUALIFICATIONS AND MEETS THE REQUIREMENTS SET OUT IN THE ONTARIO BUILDING CODE TO BE A DESIGNER.

QUALIFICATION INFORMATION
 Allan Whiting 23177
 BCIN
 HUNT DESIGN ASSOCIATES INC. 19695

HUNT
 DESIGN ASSOCIATES INC.
 www.huntdesign.ca

GOLDPARK HOMES - 221081
 PINE VALLEY PH. 2, VAUGHAN, ONT.

Drawn By: JB
 Checked By: VS
 Scale: 3/16"=1'-0"
 8966 Woodbine Ave, Markham, ON L3R 0J7
 T 905.737.5133 F 905.737.7326

FRONT ELEVATION EL. 'B'
 UNIT 4201 - THE MAPLEWOOD
 REV.2022.08.05

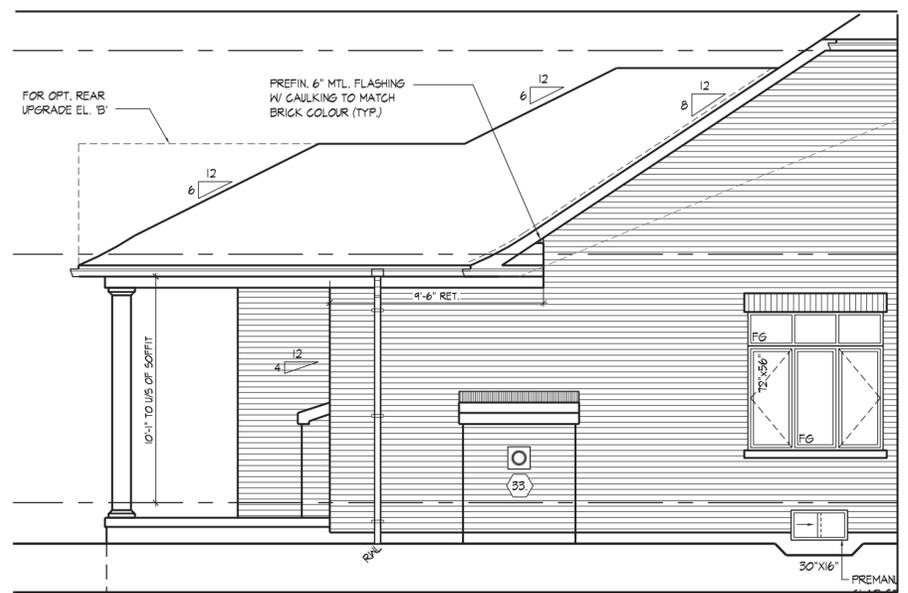

PART. LEFT SIDE ELEVATION 'B' W/ OPT. LOGGIA

REFER TO FRONT ELEVATION FOR TYPICAL NOTES & INFORMATION

ROOF OVERHANGS TO BE 15' UNLESS NOTED OTHERWISE

WINDOW SUMMARY			
PER O.B.C. TABLE 8.10.15.4			
LEFT SIDE ELEVATION B			
QUAN.	WIDTH	DEPTH	WINDOW / DOOR FRAME SIZE (S.F.)
1	30"	18"	2.17
1	72"	56"	24.56
1	72"	18"	6.81
2	24"	56"	14.44
2	24"	18"	3.89
2	24"	44"	11.11
1	24"	40"	5.00
0	0"	0"	0.00
0	0"	0"	0.00
0	ARCH	0.00	0.00
0	ARCH	0.00	0.00
0	ARCH	0.00	0.00

SPATIAL CALCULATION			
EXPOSING BUILDING	1258.30	S.F.	
FACE AREA	116.90	S.M.	
PORTION WALL AREA	116.90	S.M.	
LIMITING DISTANCE	7	1.2 m	
MAX. % OPENINGS	7	%	
OPENINGS ALLOWED	88.08	S.F.	
OPENINGS PROVIDED	67.76	S.F.	

ADDITIONAL NOTES

GLAZED AREA CALCULATED W/ FRAME SIZE MINUS 2" AROUND ENTIRE PERIMETER

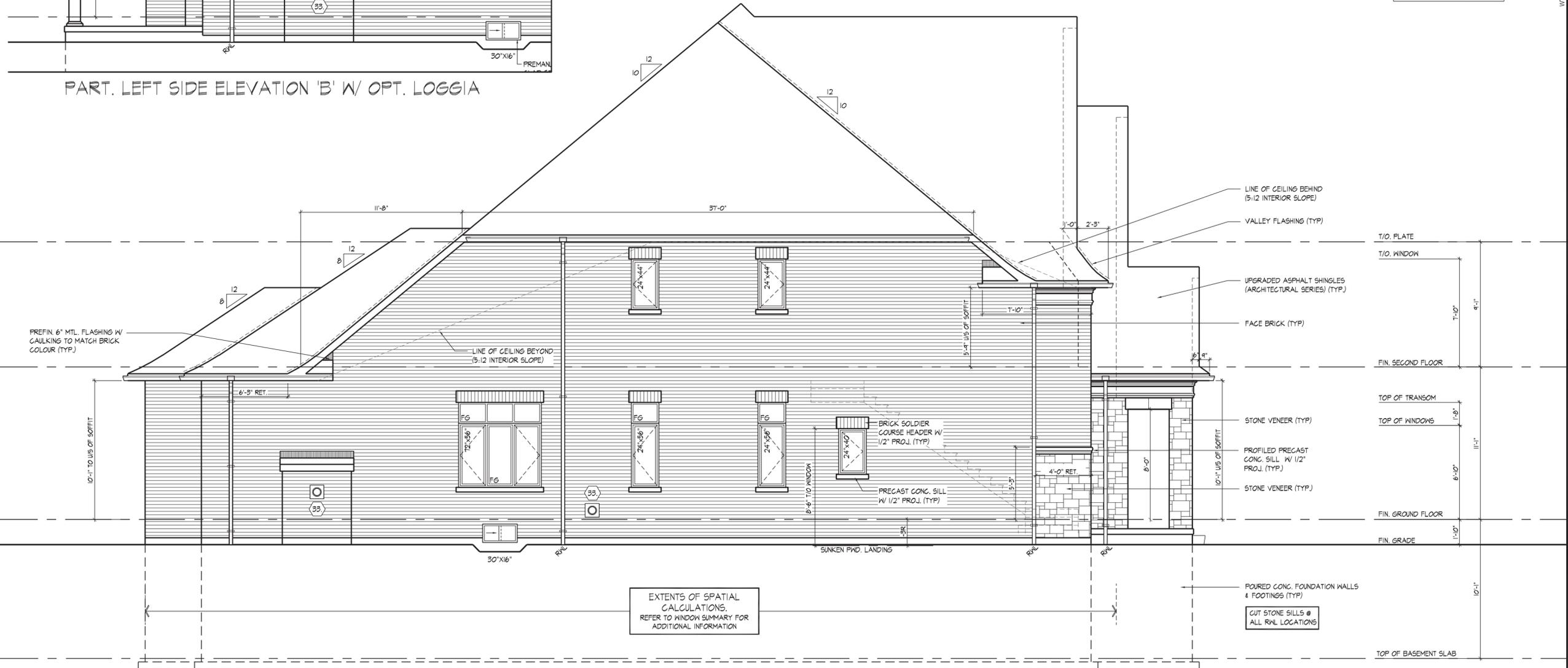

LEFT SIDE ELEVATION 'B'

EXTENTS OF SPATIAL CALCULATIONS. REFER TO WINDOW SUMMARY FOR ADDITIONAL INFORMATION

POURED CONC. FOUNDATION WALLS & FOOTINGS (TYP.)

CUT STONE SILLS @ ALL RNL LOCATIONS

It is the builder's complete responsibility to ensure that all plans submitted for approval fully comply with the Architectural Guidelines and all applicable regulations and requirements including zoning provisions and any provisions in the subdivision agreement. The Control Architect is not responsible in any way for examining or approving site (lotting) plans or working drawings with respect to any zoning or building code or permit matter or that any house can be properly built or located on its lot.

This is to certify that these plans comply with the applicable Architectural Design Guidelines approved by the City of VAUGHAN.

JOHN G. WILLIAMS LTD., ARCHITECT
ARCHITECTURAL CONTROL REVIEW AND APPROVAL

APPROVED BY: *[Signature]*
DATE: AUG 08, 2022

This stamp certifies compliance with the applicable Design Guidelines only and bears no further professional responsibility.

THE UNDERSIGNED HAS REVIEWED AND TAKES RESPONSIBILITY FOR THIS DESIGN AND HAS THE QUALIFICATIONS AND MEETS THE REQUIREMENTS SET OUT IN THE ONTARIO BUILDING CODE TO BE A DESIGNER.

QUALIFICATION INFORMATION
Name: Allan Whiting
Signature: *[Signature]*
Registration Information: BCIN 23177

HUNT DESIGN ASSOCIATES INC. 19695

HUNT DESIGN ASSOCIATES INC.
8966 Woodbine Ave, Markham, ON L3R 0J7
www.huntdesign.ca

GOLDPARK HOMES - 221081
PINE VALLEY PH. 2, VAUGHAN, ONT.
8966 Woodbine Ave, Markham, ON L3R 0J7 T 905.737.5133 F 905.737.7326

LEFT SIDE ELEVATION EL. 'B'
UNIT 4201 - THE MAPLEWOOD
REV.2022.08.05

Drawn By: JB
Checked By: VS
Scale: 3/16"=1'-0"
File Number: 217020WS4201
Page Number: 11 of 17

W/TANG / FRI AUG 5 2022 11:16 PM / K:\PROJECTS\2022\1201\081.GOLDWORKINGS\SINGLES\4221081\WS4201-MAPLEWOOD.DWG

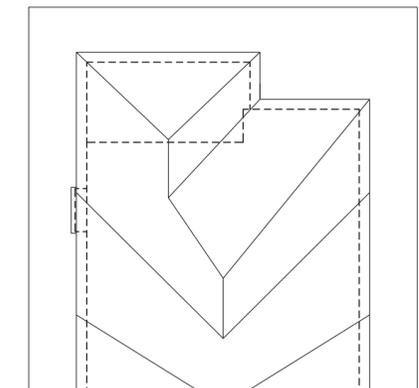

ROOF PLAN 'C'
W/ OPT. LOGGIA
N.T.S.

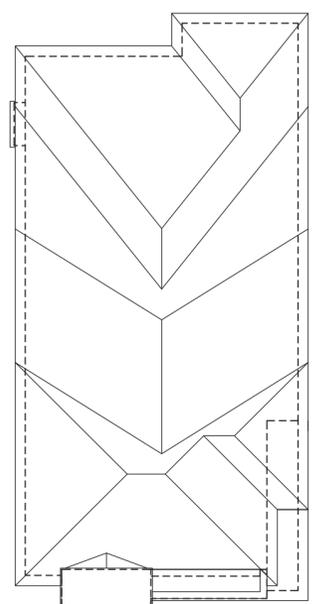

ROOF PLAN 'C'
N.T.S.

ROOF OVERHANGS TO BE 15"
UNLESS NOTED OTHERWISE

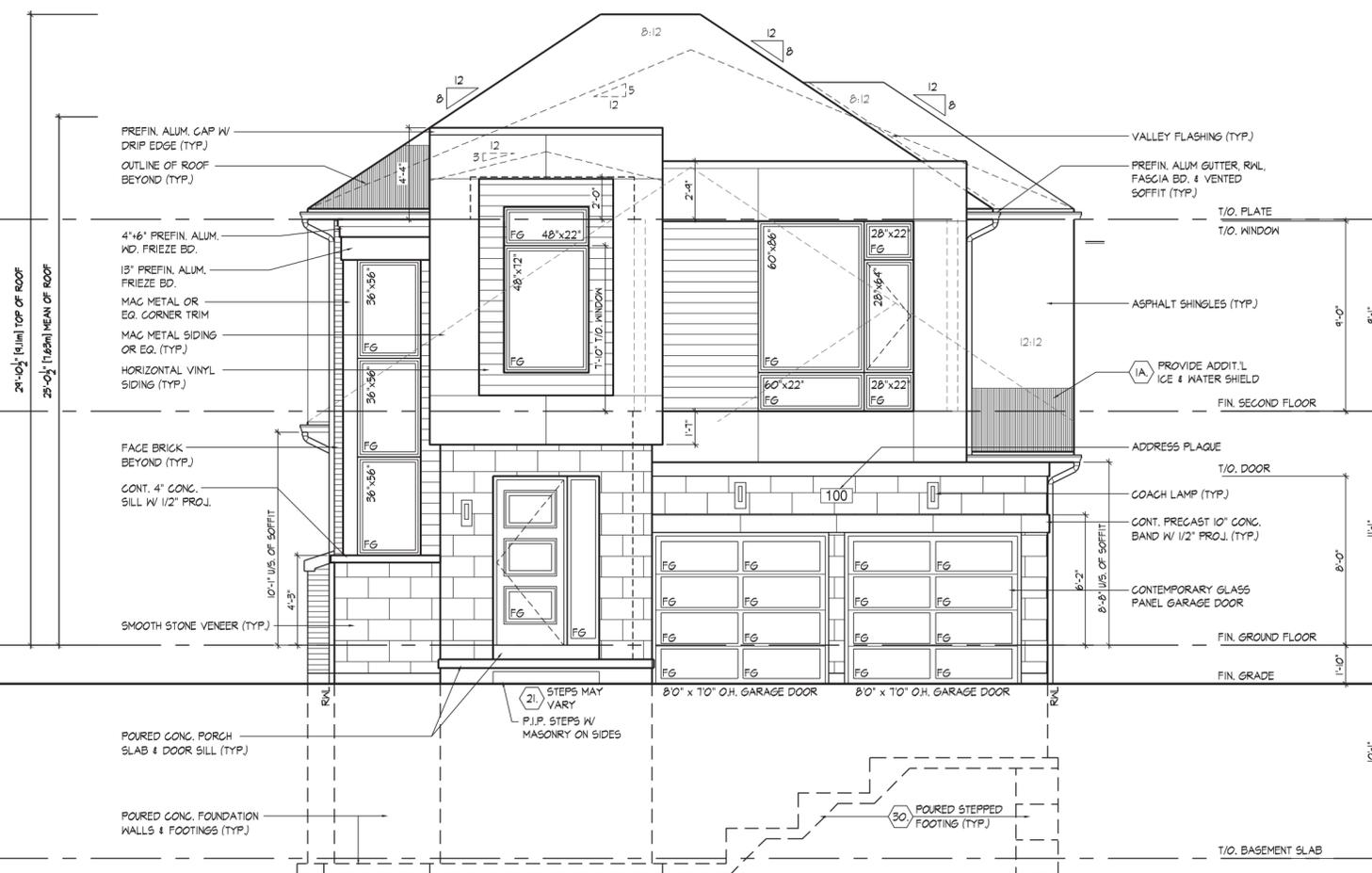

FRONT ELEVATION 'C'

It is the builder's complete responsibility to ensure that all plans submitted for approval fully comply with the Architectural Guidelines and all applicable regulations and requirements including zoning provisions and any provisions in the subdivision agreement. The Control Architect is not responsible in any way for examining or approving site (lotting) plans or working drawings with respect to any zoning or building code or permit matter or that any house can be properly built or located on its lot.

This is to certify that these plans comply with the applicable Architectural Design Guidelines approved by the City of VAUGHAN.

JOHN G. WILLIAMS LTD., ARCHITECT
ARCHITECTURAL CONTROL REVIEW
AND APPROVAL
APPROVED BY: [Signature]
DATE: AUG 08, 2022
This stamp certifies compliance with the applicable Design Guidelines only and bears no further professional responsibility.

THE UNDERSIGNED HAS REVIEWED AND TAKES RESPONSIBILITY FOR THIS DESIGN AND HAS THE QUALIFICATIONS AND MEETS THE REQUIREMENTS SET OUT IN THE ONTARIO BUILDING CODE TO BE A DESIGNER.

QUALIFICATION INFORMATION
NAME: Allan Whiting
SIGNATURE: [Signature] BCIN: 23177
REGISTRATION INFORMATION: HUNT DESIGN ASSOCIATES INC. 19695

HUNT DESIGN ASSOCIATES INC.
www.huntdesign.ca

GOLDPARK HOMES - 221081
PINE VALLEY PH. 2, VAUGHAN, ONT.
Rev. 2022.08.05

Drawn By: WT
Checked By: VS
Scale: 3/16"=1'-0"
8966 Woodbine Ave, Markham, ON L3R 0J7
T 905.737.5133 F 905.737.7326

File Number: 217020WS4201
Page Number: 13 of 17

FRONT ELEVATION EL 'C'
UNIT 4201 - THE MAPLEWOOD
REV.2022.08.05

All drawings specifications related documents and design are the copyright property of Hunt Design Associates (H.D.A.). Reproduction of this property in whole or in part is strictly prohibited without H.D.A.'s written permission (H.D.A. assumes no responsibility or liability for this property unless it bears the appropriate BCIN number and original signature.)



PART. REAR ELEVATION 'A', 'B' & 'C' W/ OPT. LOGGIA

ROOF OVERHANGS TO BE 15' UNLESS NOTED OTHERWISE

REFER TO FRONT ELEVATION FOR TYPICAL NOTES & INFORMATION

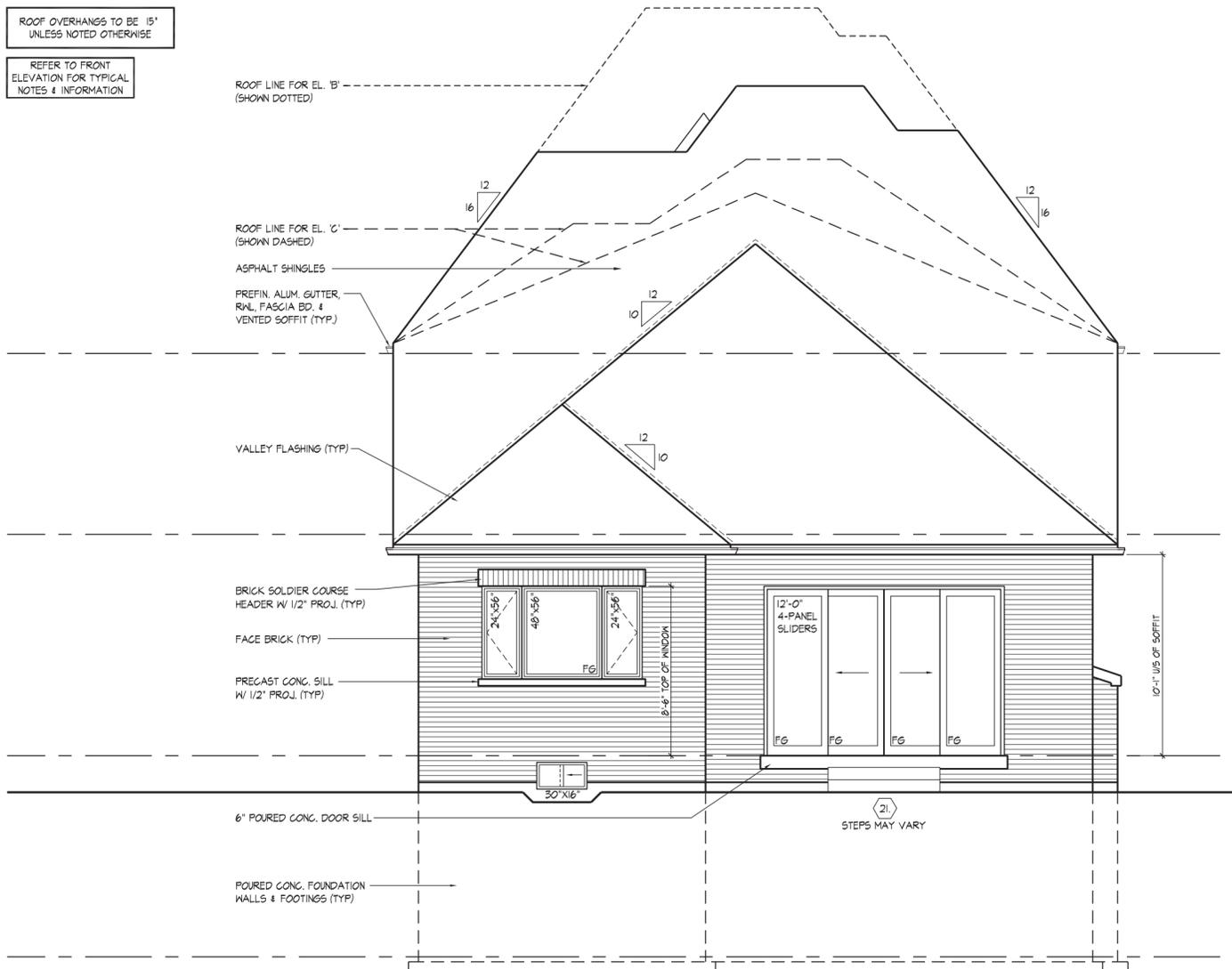

REAR ELEVATION 'A', 'B' & 'C'

WINDOW SUMMARY			
PER O.B.C. TABLE 9.10.15.4			
REAR ELEVATION A & B			
QUAN.	HT.	WT.	WINDOW / DOOR FRAME SIZE (S.F.)
2	30"	18"	4.33
2	24"	56"	14.44
1	48"	56"	15.89
1	40"	64"	15.00
1	40"	20"	4.00
1	36"	20"	3.56
0	0"	0"	0.00
0	0"	0"	0.00
0	0"	0"	0.00
0	0"	0"	0.00
1	DOOR	20.50	20.50
0	ARCH	0.00	0.00
0	ARCH	0.00	0.00
0	ARCH	0.00	0.00
SPATIAL CALCULATION			
EXPOSING BUILDING	740.87	S.F.	
FACE AREA	68.81	S.M.	
PORTION WALL AREA	740.87	S.F.	
	68.81	S.M.	
LIMITING DISTANCE	7.50 m		
MAX. % OPENINGS	50.50	%	
OPENINGS ALLOWED	374.04	S.F.	
OPENINGS PROVIDED	77.72	S.F.	
ADDITIONAL NOTES			
GLAZED AREA CALCULATED W/ FRAME SIZE MINUS 2" AROUND ENTIRE PERIMETER			

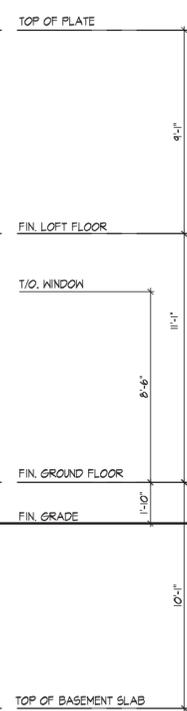

It is the builder's complete responsibility to ensure that all plans submitted for approval fully comply with the Architectural Guidelines and all applicable regulations and requirements including zoning provisions and any provisions in the subdivision agreement. The Control Architect is not responsible in any way for examining or approving site (lotting) plans or working drawings with respect to any zoning or building code or permit matter or that any house can be properly built or located on its lot.

This is to certify that these plans comply with the applicable Architectural Design Guidelines approved by the City of VAUGHAN.

JOHN G. WILLIAMS LTD., ARCHITECT
ARCHITECTURAL CONTROL REVIEW
AND APPROVAL

APPROVED BY: *[Signature]*
DATE: Aug 06, 2022

This stamp certifies compliance with the applicable Design Guidelines only and bears no further professional responsibility.

THE UNDERSIGNED HAS REVIEWED AND TAKES RESPONSIBILITY FOR THIS DESIGN AND HAS THE QUALIFICATIONS AND MEETS THE REQUIREMENTS SET OUT IN THE ONTARIO BUILDING CODE TO BE A DESIGNER.

QUALIFICATION INFORMATION:
NAME: Alban Whiting SIGNATURE: *[Signature]* BCIN: 23177

REGISTRATION INFORMATION:
HUNT DESIGN ASSOCIATES INC. 19695

HUNT DESIGN ASSOCIATES INC.
www.huntdesign.ca

GOLDPARK HOMES - 221081
PINE VALLEY PH. 2, VAUGHAN, ONT.

Drawn By: JB Checked By: VS Scale: 3/16"=1'-0" File Number: 217020WS4201 Page Number: 16 of 17

8966 Woodbine Ave, Markham, ON L3R 0J7 T 905.737.5133 F 905.737.7326

REAR ELEVATION 'A', 'B' & 'C'
UNIT 4201 - THE MAPLEWOOD
REV.2022.08.05

All drawings specifications related documents and design are the copyright property of Hunt Design Associates (H.D.A.). Reproduction of this property in whole or in part is strictly prohibited without H.D.A.'s written permission (H.D.A. assumes no responsibility or liability for this property unless it bears the appropriate BCIN number and original signature.)



100184842
August 06, 2022
PROVINCE OF ONTARIO
LICENSED PROFESSIONAL ENGINEER
A. KONG
100184842
August 06, 2022
PROVINCE OF ONTARIO
LICENSED PROFESSIONAL ENGINEER

FOR STRUCTURAL ONLY. EXCLUDING
ENGINEERED ROOF TRUSS, FLOOR
JOIST, AND FLOOR LVL BEAM DESIGN.

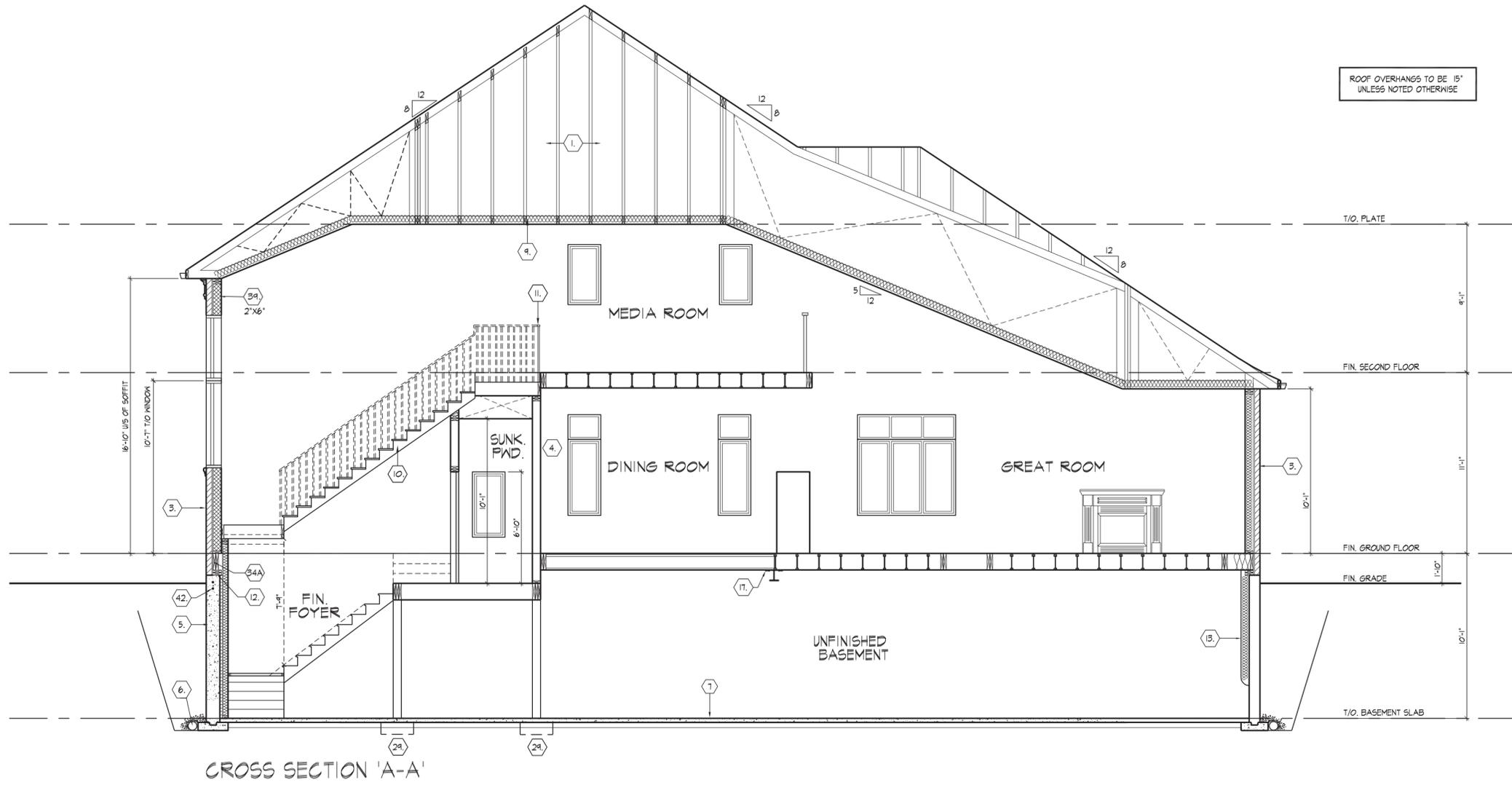

CROSS SECTION 'A-A'

<p>THE UNDERSIGNED HAS REVIEWED AND TAKES RESPONSIBILITY FOR THIS DESIGN AND HAS THE QUALIFICATIONS AND MEETS THE REQUIREMENTS SET OUT IN THE ONTARIO BUILDING CODE TO BE A DESIGNER.</p> <p>QUALIFICATION INFORMATION: Alan Whiting (Signature) 23177 HUNT DESIGN ASSOCIATES INC. 19695</p>		<p>HUNT DESIGN ASSOCIATES INC. 8966 Woodbine Ave, Markham, ON L3R 0J7 T 905.737.5133 F 905.737.7326 www.hunt-design.ca</p>		<p>GOLDPARK HOMES - 221081 PINE VALLEY PH. 2, VAUGHAN, ONT.</p>		<p>CROSS SECTION 'A-A' & DETAILS UNIT 4201 - THE MAPLEWOOD REV.2022.08.05</p>	
<p>Drawn By: JB Checked By: VS Scale: 3/16"=1'-0"</p>	<p>File Number: 217020WS4201 Page Number: 17 of 17</p>	<p>All drawings specifications related documents and design are the copyright property of Hunt Design Associates (H.D.A.). Reproduction of this property in whole or in part is strictly prohibited without H.D.A.'s written permission. (H.D.A. assumes no responsibility or liability for this property unless it bears the appropriate BCIN number and original signature.)</p>					

WTANG | FRI AUG 5 22 01:16 PM | K:\PROJECTS\2022\221081.GOLDPARK HOMES\42221081\4201-MAPLEWOOD.DWG

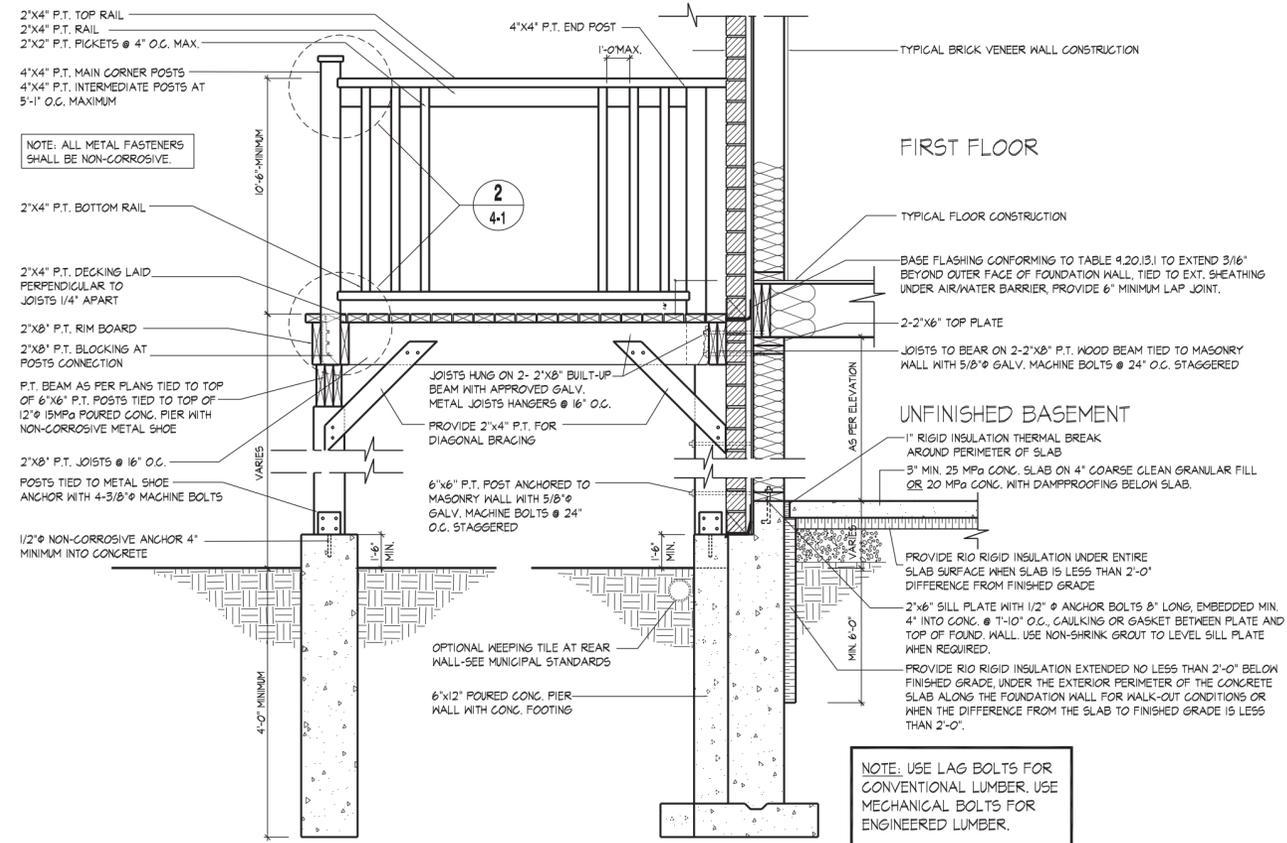

09 MASONRY VENEER, TYPICAL WOOD DECK FOR WALK OUT BASEMENT
N.T.S.

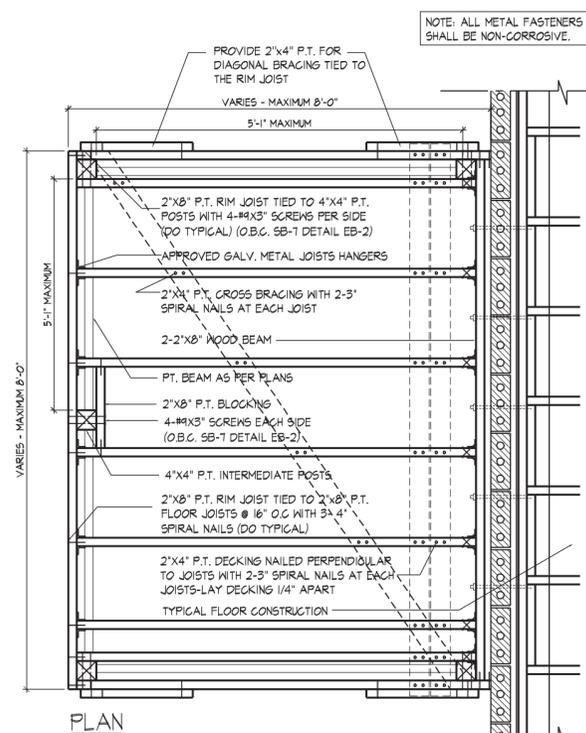

GENERAL NOTES
 1. ALL CONSTRUCTION SHALL BE IN ACCORDANCE WITH THE O.B.C. AND SB-1 OF THE SUPPLEMENTARY STANDARD
 2. LUMBER GRADES SHALL NOT BE LESS THAN NO. 2 SPF. LUMBER SHALL BE FREE OF LOOSE KNOTS AND ALL CUT ENDS OF PRESERVATIVE TREATED LUMBER SHALL BE TREATED TO PREVENT DECAY
 SPECIES FOR POSTS, PICKETS AND NAILS SHALL BE DOUGLAS FIR-LARCH, HEM-FIR, SPRUCE-PINE-FIR
 3. ALL FASTENERS, SCREWS AND NAILS SHALL BE RESISTANT TO CORROSION - NAILS TO BE COMMON SPIRAL

10 MASONRY VENEER, TYPICAL DECK FRAMING PLAN
N.T.S.

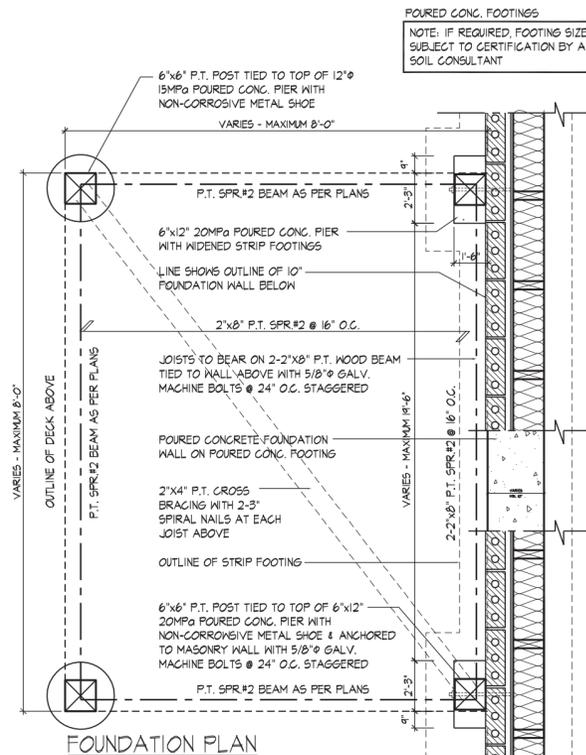

11 MASONRY VENEER, TYPICAL DECK FOUNDATION PLAN
N.T.S.



FOR STRUCTURAL ONLY. EXCLUDING
 ENGINEERED ROOF TRUSS, FLOOR
 JOIST, AND FLOOR LVL BEAM DESIGN.

HUNT DESIGN ASSOCIATES INC.
 8966 Woodbine Ave, Markham, ON L3R 0J7 T 905.737.5133 F 905.737.7326
 www.hunt-design.ca

GOLDPARK HOMES - 221081 UNIT 4201 - THE MAPLEWOOD
 PINE VALLEY PH. 2, VAUGHAN, ONT. REV.2022.08.05

Drawn By: Alan Whiting (AW) Signature: [Signature] 23177
 Checked By: VS
 Scale: 3/16"=1'-0"
 File Number: 217020WS4201
 Page Number: W3 of W3

W/TANG / FRI AUG 5 2022 01:16 PM / K:\PROJECTS\2021\221081.GOLDPARK\WORKING\SINGLES\4221081\WS4201-MAPLEWOOD.DWG