

Sales Selection Sheet
Checklist

1 of 39

LOT 351 Model: 28-2590 A THE BRISTOL
PURCHASERS: MUKESH BOHRA/SHRUTI BOHRA
VENDOR: Heathwood Homes (Huron) Limited

BUILD UP WALL ABOVE GREAT ROOM FIREPLACE TO CEILING

- WOB
- DECK
- FINISHED BASEMENT
- COLD CELLAR

UPGRADED / MODIFIED ELEVATION

- CORNER UPGRADE
- REAR UPGRADE
- SIDE UPGRADE

CEILING UPGRADE - SMOOTH

- MAIN FLOOR
- SECOND FLOOR
- BASEMENT

ADDITIONAL ROUGH-INS

- 200 AMP SERVICE (STD IN SINGLES)
- WET BAR ROUGH-IN
- HUMIDIFIER
- AIR CONDITIONING (SITE STD)

GAS ROUGH-IN

- STOVE
- DRYER
- BBQ
- ADDITIONAL FIREPLACE

KITCHEN: HOODFAN VENTING SIZE

- 6 IN ROUND DUCT
- 7 IN ROUND DUCT

FULL BASEMENT STAIRS:	Paint Grade
UPPER BASEMENT STAIRS:	N/A
LOWER LEVEL STAIRS:	N/A
MAIN STAIRS:	All Oak
MEDIA STAIRS (if applicable):	N/A
LOFT STAIRS (if applicable):	N/A

Dec 7/22 _____
Date Purchaser: *on file*

Dec 7/22 _____
Date Decor Consultant: *BRENDA LURER*

Dec 7/22 _____
Date Purchaser:

~~Signature~~
-12- 07 2022 _____
Date Heathwood Homes (Huron) Limited

Locked Date:

Approved _____

Customer Colours

MUKESH BOHRA/SHRUTI BOHRA
 Project: Wallaceton
 Unit: 351, Phase: 3
 Model: 28-2590 A THE BRISTOL

Created: 9/2/2021 09:15:42

Locked:

Closed:

Kitchen

Cabinet Colour/Style	9111	Viking III-SIMCOE ORCHID 3DL ***STD***
Island Cabinet Colour/Style	9111	Viking III-SIMCOE ORCHID 3DL ***STD***
Cabinet Hardware	7667	12881-HARDWARE ***STD***
Countertop	9069	MSI Quartz GROUP 1 ICED WHITE ***STD***
Island Countertop	9069	MSI Quartz GROUP 1 ICED WHITE ***STD***
Countertop Edge	4010	SINGLE POLISHED STRAIGHT EDGE 3/4 INCH ***STD***



- Please note some islands may require a seam as per manufacturer and fabricator discretions.

Sink	9487	Plumbing-KINDRED Kitchen Sink Collection - Reginox ND1831 U/9-Double (equal size) Bowl Undermount Sink (or equivalent)-Stainless Steel	PG 22
HoodFan	34	AV1308 Air King 30 STAINLESS STEEL UNDER CABINET RANGE HOOD **STD**	PG 33-34
Stove Opening	34	Standard stove opening is 30" and standard dishwasher opening is 24". Any gas stove will require backsplash or stainless steel backing to avoid fire hazards.	
Disclaimer	34	Purchasers acknowledge: Heathwood Homes and its contractors will not be responsible for any kitchen cabinet changes due to appliances dimension changes after	
Backsplash	1111	N/A *****	
Backsplash Grout	1111	N/A *****	
Backsplash Tile Pattern	1111	N/A *****	

- Purchasers have been advised: standard fridge opening is a minimum 37 3/8 x 73 3/8 inches. Ice Waterline Rough-In is included.

Kitchen / Breakfast

Flooring	9358	Red Oak Pearl-Vintage Engineered-TITANIUM-3/4 inch x 3 1/4 inch ***UPG***
Floor Tile Grout	1111	N/A *****
Floor Tile Pattern	1111	N/A *****

Comment

Customer Colours

MUKESH BOHRA/SHRUTI BOHRA
 Project: Wallaceton
 Unit: 351, Phase: 3
 Model: 28-2590 A THE BRISTOL

Created: 9/2/2021 09:13:42

Locked:

Closed:

Foyer

Flooring	5589	GE.BY.PEN.1313 New Byzantine Pentallic (Grey) 13 x13 ***STD***
Floor Tile Grout	2229	Grout-(27) Silver ***STD***
Floor Tile Pattern	2026	STANDARD SQUARE ***STD***

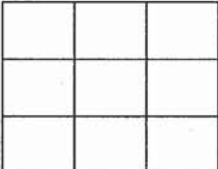

Comment

Powder Room

Flooring	5589	GE.BY.PEN.1313 New Byzantine Pentallic (Grey) 13 x13 ***STD***
Floor Tile Grout	2225	Grout-(27) Silver ***STD***
Floor Tile Pattern	3000	STANDARD SQUARE ***STD***

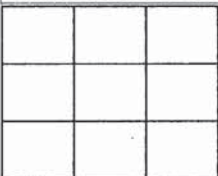

Plumbing Fixture (Colour) 1737 Plumbing Fixtures-WHITE ***STD***

Comment

Mud Room / Laundry

Flooring	5589	GE.BY.PEN.1313 New Byzantine Pentallic (Grey) 13 x13 ***STD***
Floor Tile Grout	2225	Grout-(27) Silver ***STD***
Floor Tile Pattern	3000	STANDARD SQUARE ***STD***

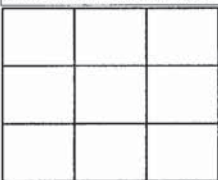

Opt. Cabinet Colour/Style - Uppers 1111 N/A *****

Opt. Cabinet Hardware - Uppers 1111 N/A *****

Opt. Cabinet Colour/Style - Base 9111 VIKING III SIMCOE ORCHID 3DL ***UPG***

Opt. Cabinet Hardware - Base 7667 12881-HARDWARE ***STD***

Opt. Countertop 8796 6698-46-Countertop-PALOMA POLAR ETCHINGS
FINISH-Formica ***STD***

Opt. Countertop Edge 1111 N/A *****

Comment BRISTOL HAS STD LAUNDRY BASE

Customer Colours

MUKESH BOHRA/SHRUTI BOHRA
Project: Wallaceton
Unit: 351, Phase: 3
Model: 28-2590 A THE BRISTOL

Locked:
Closed:

Main Hall

Flooring 9358 Red Oak Pearl-Vintage Engineered-TITANIUM-3/4 inch x 3 1/4 inch ***STD***

Comment

Dining Room

Flooring 9358 Red Oak Pearl-Vintage Engineered-TITANIUM-3/4 inch x 3 1/4 inch ***STD***

Comment

Great Room

Flooring 9358 Red Oak Pearl-Vintage Engineered-TITANIUM-3/4 inch x 3 1/4 inch ***STD***

Comment

Great Room Fireplace

Type 8869 Majestic MERC32 ***STD***

Mantle 1439 NF 17-Paint Grade Mantle-Flat Wall-WHITE ***STD***

Surround (Opt.) 1111 N/A *****

PG 21

- Purchasers have been advised: heat from the FP can damage TV above a FP and items placed on mantle.

Comment BUILD UP WALL ABOVE FIREPLACE TO CEILING

Upper Hall

Flooring 9504 87354-MINOTAUR-OVERCAST-40 oz Poly ***STD***

Comment CARPET OVERCAST

Master Bedroom

Flooring 9504 87354-MINOTAUR-OVERCAST-40 oz Poly ***STD***

Comment

Bedroom 2

Flooring 9504 87354-MINOTAUR-OVERCAST-40 oz Poly ***STD***

Comment

Customer Colours

MUKESH BOHRA/SHRUTI BOHRA
 Project: Wallaceton
 Unit: 351, Phase: 3
 Model: 28-2590 A THE BRISTOL

Created: 9/2/2021 09:13:42

Locked:

Closed:

Bedroom 3

Flooring	9504	87354-MINOTAUR-OVERCAST-40 oz Poly ***STD***
Comment		

Bedroom 4

Flooring	9504	87354-MINOTAUR-OVERCAST-40 oz Poly ***STD***
Comment		

Master Ensuite

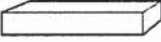
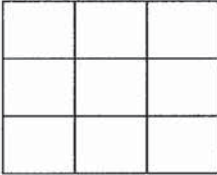
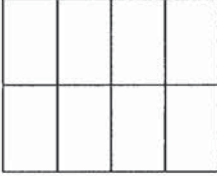
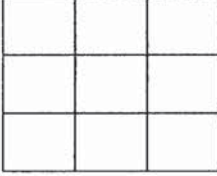
Cabinet Colour/Style	9111	Viking III-SIMCOE ORCHID 3DL ***STD***
Cabinet Hardware	7667	12881-HARDWARE ***STD***
Countertop	9069	MSI Quartz GROUP 1 ICED WHITE ***STD***
Countertop Edge	4010	SINGLE POLISHED STRAIGHT EDGE 3/4 INCH ***STD*** 
Floor Tile	9437	TH.CT.WHT.1212.MT-Construct-White Matte-12 x 12 STD ***STD***
Floor Tile Grout	2225	Grout-(27) Silver ***STD***
Floor Tile Pattern	3000	STANDARD SQUARE ***STD*** 
Shower Wall Tile	5411	QT.SP.WHT.0810-Splendour-White-8 inch x 10 inch ***STD***
Shower Wall Tile Grout	2226	Grout-(00) White ***STD***
Shower Wall Tile Pattern	3090	VERTICAL STACKED ***STD*** 
Shower Floor Tile	8661	OD.ON.SWT.0202.MT.N-Ontario Series Mosaic-Snow White Matte-2 x 2 ***STD***
Shower Floor Tile Grout	2226	Grout-(00) White ***STD***
Shower Floor Tile Pattern	3000	STANDARD SQUARE ***STD*** 
Shower Jamb(s) and Sill(s)	8923	Shower Jamb / Sill-Thassos White ***STD***
Plumbing Fixture (colour)	1727	Plumbing Fixture WHITE ***STD***

Customer Colours

MUKESH BOHRA/SHRUTI BOHRA
 Project: Wallaceton
 Unit: 351, Phase: 3
 Model: 28-2590 A THE BRISTOL

Created: 9/2/2021 09:15:42

Locked:

Closed:

Plumbing Fixture (colour)	1737	Plumbing Fixtures-WHITE STD
Comment		

Main Bathroom

Cabinet Colour/Style	9111	Viking III-SIMCOE ORCHID 3DL ***STD***
Cabinet Hardware	7667	12881-HARDWARE ***STD***
Countertop	8796	6698-46-Countertop-PALOMA POLAR ETCHINGS FINISH-Formica ***STD***
Countertop Edge	1111	N/A *****

Floor Tile	9437	TH.CT.WHT.1212.MT-Construct-White Matte-12 x 12 STD ***STD***
------------	------	---

Floor Tile Grout	2225	Grout-(27) Silver ***STD***
------------------	------	-----------------------------

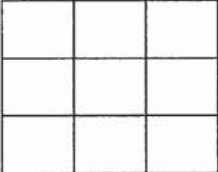
Floor Tile Pattern	3000	STANDARD SQUARE ***STD***
		

Shower Wall Tile	5411	QT.SP.WHT.0810-Splendour-White-8 inch x 10 inch ***STD***
------------------	------	---

Shower Wall Tile Grout	2226	Grout-(00) White ***STD***
------------------------	------	----------------------------

Shower Wall Tile Pattern	3090	VERTICAL STACKED ***STD***
		

Shower Floor Tile	8661	OD.ON.SWT.0202.MT.N-Ontario Series Mosaic-Snow White Matte-2 x 2 ***STD***
-------------------	------	--

Shower Floor Tile Grout	2226	Grout-(00) White ***STD***
-------------------------	------	----------------------------

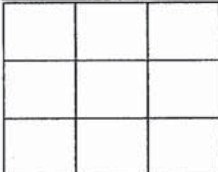
Shower Floor Tile Pattern	3000	STANDARD SQUARE ***STD***
		

Shower Jamb(s) and Sill(s)	8923	Shower Jamb / Sill-Thassos White ***STD***
----------------------------	------	--

Plumbing Fixture (colour)	1737	Plumbing Fixtures-WHITE ***STD***
---------------------------	------	-----------------------------------

Comment		
---------	--	--

Shared Ensuite

Cabinet Colour/Style	9111	Viking III-SIMCOE ORCHID 3DL ***STD***
----------------------	------	--

Cabinet Hardware	7667	12881-HARDWARE ***STD***
------------------	------	--------------------------

Countertop	8796	6698-46-Countertop-PALOMA POLAR ETCHINGS FINISH-Formica ***STD***
------------	------	---

Countertop Edge	1111	N/A *****
-----------------	------	-----------

Customer Colours

MUKESH BOHRA/SHRUTI BOHRA
 Project: Wallaceon
 Unit: 351, Phase: 3
 Model: 28-2590 A THE BRISTOL

Created: 9/2/2021 09:15:42

Locked:

Closed:

Floor Tile	9437	TH.CT.WHT.1212.MT-Construct-White Matte-12 x 12 STD ***STD***
------------	------	--

Floor Tile Grout	2225	Grout-(27) Silver ***STD***
------------------	------	-----------------------------

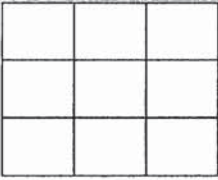
Floor Tile Pattern	3000	STANDARD SQUARE ***STD***
		

Wall Tile	5411	QT.SP.WHT.0810-Splendour-White-8 inch x 10 inch ***STD***
-----------	------	--

Wall Tile Grout	2226	Grout-(00) White ***STD***
-----------------	------	----------------------------

Wall Tile Pattern	3090	VERTICAL STACKED ***STD***
		

Opt. Shower Floor Tile	1111	N/A *****
------------------------	------	-----------

Opt. Shower Floor Tile Grout	1111	N/A *****
------------------------------	------	-----------

Opt. Shower Floor Tile Pattern	1111	N/A *****
--------------------------------	------	-----------

Opt. Shower Jamb(s) and Sill(s)	1111	N/A *****
---------------------------------	------	-----------

Plumbing Fixture (colour)	1737	Plumbing Fixtures-WHITE ***STD***
---------------------------	------	-----------------------------------

Comment		
---------	--	--

Lower Level Recreation Room (Opt. Finish)

Flooring	1111	N/A *****
----------	------	-----------

Comment		
---------	--	--

Lower Level Bathroom (Opt. Finished Bas)

Cabinet Colour/Style	1111	N/A *****
----------------------	------	-----------

Cabinet Hardware	1111	N/A *****
------------------	------	-----------

Countertop	1111	N/A *****
------------	------	-----------

Countertop Edge	1111	N/A *****
-----------------	------	-----------

Floor Tile	1111	N/A *****
------------	------	-----------

Floor Tile Grout	1111	N/A *****
------------------	------	-----------

Floor Tile Pattern	1111	N/A *****
--------------------	------	-----------

Customer Colours

MUKESH BOHRA/SHRUTI BOHRA
 Project: Wallaceton
 Unit: 351, Phase: 3
 Model: 28-2590 A THE BRISTOL

Created: 9/2/2022 09:15:12

Locked:

Closed:

Shower

Shower Wall Tile	1111	N/A *****
Shower Wall Tile Grout	1111	N/A *****
Shower Wall Tile Pattern	1111	N/A *****

Shower Floor Tile	1111	N/A *****
Shower Floor Tile Grout	1111	N/A *****
Shower Floor Tile Pattern	1111	N/A *****

Shower Jamb(s) and Sill(s)	1111	N/A *****
Plumbing Fixture (colour)	1111	N/A *****

Comment

Main Stairs

Type	1714	Oak Stairs ***STD MAIN STAIRS***
Colour	7940	Sambucca STAIN TO COMPLIMENT HARDWOOD AND WILL VARY FROM FLOORING ***99***
Handrail/Pickets/Posts Type	7652	1 5/16 inch Square pickets with 3 1/2? Square/Cap Post(s)-ALL OAK ***STD***
Handrail/Pickets/Posts Colour	7940	Sambucca STAIN TO COMPLIMENT HARDWOOD AND WILL VARY FROM FLOORING ***99***
Custom Stain/Paint	1111	N/A *****
Landing(s)	9059	Red Oak-Vintage 3 1/4 inch Pre-Sanded Smooth Unfinished Red Oak-Unfinished-3/4 inch x 3 1/4inch
Opt. Carpet Runner	1111	N/A *****

Comment

Lower Level Stairs

Type	1713	Paint Grade Stairs ***STD UNFINISHED BASEMENT STAI
Colour	1111	N/A *****
Handrail/Pickets/Posts Type	1111	N/A *****
Handrail/Pickets/Posts Colour	1111	N/A *****

Customer Colours

MUKESH BOHRA/SHRUTI BOHRA
 Project: Wallaceton
 Unit: 351, Phase: 3
 Model: 28-2590 A THE BRISTOL

Created: 9/2/2021 09:15:42
 Locked:
 Closed:

Custom Stain/Paint	1111	N/A *****
Landing(s)	1111	N/A *****
Opt. Carpet Runner	1111	N/A *****
Comment		

Throughout

Switches and Plug	5796	Decora White Switches and Plugs ***STD***
Thresholds	2232	Metal Thresholds ***STD***
Underpad	1079	500 Series-Underpad ***STD***
Trim Size	8705	4 1/4 Baseboard and 2 3/4 Casings ***STD***
Trim - Paint Colour	1716	Trim-WHITE ***STD***
Walls - Paint Colour	1717	22-Wall-WARM GREY ***STD***
Comment		

Purchaser: MUKESH BOHRA Oct 22/22 Brenda huker Oct 22/22
 Signatures Date Decor Consultant Date
 ov file
 Purchaser: SHRUTI BOHRA 11 M/Rosens -12-08-2022
 Date Wallaceton Date Approved



CONSTRUCTION SUMMARY

Lot: 351
Model: 28-2590 A THE BRISTOL
Project/Phase: Wallaceton / 3

Offer Worksheet	The Purchaser(s) acknowledge that they have NOT been referred by an existing Heathwood Homeowner and therefor are not entitled to a referral fee under Heathwood Homes Referral program. Note:
--------------------	---

Offer Worksheet	Ten Thousand Dollars (\$10,000) At D?cor. (No Cash Value) Singles Note:
--------------------	--



CONSTRUCTION SUMMARY

Lot: 351
Model: 28-2590 A THE BRISTOL
Project/Phase: Wallaceton / 3

ADMIN FEE

Invoice	Qty.	Description
---------	------	-------------

APPLIANCES

Invoice	Qty.	Description
---------	------	-------------

1147 314,277 23Feb23 **	1	KITCHEN - GRANITE - GRANITE CUTOUT W/ STRAIGHT EDGE POLISH TO ACCOMMODATE COOK TOP SKETCH # 3 SEE SPECS
----------------------------------	---	--

CABINETRY

Invoice	Qty.	Description
---------	------	-------------

1147 314,277 23Feb23 **	1	KITCHEN - GRANITE - GRANITE CUTOUT W/ STRAIGHT EDGE POLISH TO ACCOMMODATE COOK TOP SKETCH # 3 SEE SPECS
1147 23Feb23 NoCat	1	KITCHEN - RELOCATE STANDARD BANK OF DRAWERS TO ISLAND BESIDE DISHWASHER SKETCH # 3
1147 345,977 23Feb23 **	1	KITCHEN / BREAKFAST - HARDWOOD - VINTAGE 3 1/4 IN - KITCHEN / BREAKFAST - UPG CABINETRY-Raise Cabinet; CERAMICS-Delete Std Ceramics
1147 343,217 23Feb23	1	- CABINETRY - OPT. BUILT IN - VIKING II/III - UPG SKETCH # 3 DRYWAL-Notify; FRAMING-Modify Bulkhead; GRANITE-delete partial countertop due to Built-in; PAINTING

CERAMICS

Invoice	Qty.	Description
---------	------	-------------

1147 345,977 23Feb23 **	1	KITCHEN / BREAKFAST - HARDWOOD - VINTAGE 3 1/4 IN - KITCHEN / BREAKFAST - UPG CABINETRY-Raise Cabinet; CERAMICS-Delete Std Ceramics
----------------------------------	---	---

COLD CELLAR

Invoice	Qty.	Description
---------	------	-------------

1147 345,661 23Feb23	1	Cold Cellar - COLD CELLAR - UPG SKETCH # 1 CONCRETE DRAIN-Notify; DRYWALL-Notify; ELECTRICAL-Supply and install light and switch; FORMING-Notify; FRAMING-Notify; INTERIOR TRIM-Supply and install metal insulated slab door including hardware
----------------------------	---	--



CONSTRUCTION SUMMARY

Lot: 351
Model: 28-2590 A THE BRISTOL
Project/Phase: Wallaceton / 3

CONCRETE AND DRAIN

Invoice	Qty.	Description
1147 345,661 23Feb23 **	1	Cold Cellar - COLD CELLAR - UPG SKETCH # 1 CONCRETE DRAIN-Notify; DRYWALL-Notify; ELECTRICAL-Supply and install light and switch; FORMING-Notify; FRAMING-Notify; INTERIOR TRIM-Supply and install metal insulated slab door including hardware

DRYWALL

Invoice	Qty.	Description
1147 345,661 23Feb23 **	1	Cold Cellar - COLD CELLAR - UPG SKETCH # 1 CONCRETE DRAIN-Notify; DRYWALL-Notify; ELECTRICAL-Supply and install light and switch; FORMING-Notify; FRAMING-Notify; INTERIOR TRIM-Supply and install metal insulated slab door including hardware
1147 346,366 23Feb23 **	1	GREAT ROOM - FIREPLACE AND MANTLE - BUILT OUT WALL ABOVE FIREPLACE TO CEILING SKETCH # 2 DRYWALL-notify; ELECTRICAL-notify; FRAMING-notify; HEATING/AIR CONDITIONING-notify; INTERIOR TRIM-notify; PAINTING-notify
1147 343,217 23Feb23 **	1	- CABINETS - OPT. BUILT IN - VIKING II/III - UPG SKETCH # 3 DRYWALL-Notify; FRAMING-Modify Bulkhead; GRANITE-delete partial countertop due to Built-in; PAINTING-



CONSTRUCTION SUMMARY

Lot: 351
Model: 28-2590 A THE BRISTOL
Project/Phase: Wallaceton / 3

ELECTRICAL

Invoice	Qty.	Description
1147 345,661 23Feb23 **	1	Cold Cellar - COLD CELLAR - UPG SKETCH # 1 CONCRETE DRAIN-Notify; DRYWALL-Notify; ELECTRICAL-Supply and install light and switch; FORMING-Notify; FRAMING-Notify; INTERIOR TRIM-Supply and install metal insulated slab door including hardware
1147 314,242 23Feb23	1	KITCHEN - ELECTRICAL - RELOCATION OF SWITCHES/LIGHTS (MUST SPECIFY LOCATION) - NOTE: PLUGS CANNOT BE RELOCATED- MUST PURCHASE ADDITIONAL OUTLET. RELOCATE STD 220 V TO BUILT IN OVEN LOCATION SKETCH # 3
1147 314,277 23Feb23 **	1	KITCHEN - GRANITE - GRANITE CUTOUT W/ STRAIGHT EDGE POLISH TO ACCOMMODATE COOK TOP SKETCH # 3 SEE SPECS
1147 314,340 23Feb23 **	1	KITCHEN - HEATING/AIR - ROUGH-IN GAS LINE FOR GAS STOVE AT MAIN FLOOR (SEE SPECS) (HOOK-UP NOT INCLUDED) LEAVE STANDARD 120 VOLT ELECTRICAL OUTLET ON A SEPARATE CIRCUIT. * SPECIFY IF STANDARD 220V WILL STAY OR BE RELOCATED RELOCATE STD 220V TO BUILT IN OVEN LOCATION SKETCH # 3 ELECTRICAL-Notify
1147 314,242 23Feb23	1	KITCHEN - ELECTRICAL - RELOCATION OF SWITCHES/LIGHTS (MUST SPECIFY LOCATION) - NOTE: PLUGS CANNOT BE RELOCATED- MUST PURCHASE ADDITIONAL OUTLET. RELOCATE STD KITCHEN LIGHT TO OVER ISLAND SKETCH # 2
1147 314,232 23Feb23	1	GREAT ROOM - ELECTRICAL - EXTRA WALL INTERIOR OUTLET ON EXISTING CIRCUIT (DOES NOT INCLUDE KITCHEN OUTLETS) OVER FIREPLACE ON BUILT OUT WALL 70" +/- FROM FLOOR SKETCH # 2
1147 346,366 23Feb23 **	1	GREAT ROOM - FIREPLACE AND MANTLE - BUILT OUT WALL ABOVE FIREPLACE TO CEILING SKETCH # 2 DRYWALL-notify; ELECTRICAL-notify; FRAMING-notify; HEATING/AIR CONDITIONING-notify; INTERIOR TRIM-notify; PAINTING-notify

FIREPLACE AND MANTLE

Invoice	Qty.	Description
1147 346,366 23Feb23	1	GREAT ROOM - FIREPLACE AND MANTLE - BUILT OUT WALL ABOVE FIREPLACE TO CEILING SKETCH # 2 DRYWALL-notify; ELECTRICAL-notify; FRAMING-notify; HEATING/AIR CONDITIONING-notify; INTERIOR TRIM-notify; PAINTING-notify

FORMING

Invoice	Qty.	Description
1147 345,661 23Feb23 **	1	Cold Cellar - COLD CELLAR - UPG SKETCH # 1 CONCRETE DRAIN-Notify; DRYWALL-Notify; ELECTRICAL-Supply and install light and switch; FORMING-Notify; FRAMING-Notify; INTERIOR TRIM-Supply and install metal insulated slab door including hardware



CONSTRUCTION SUMMARY

Lot: 351
Model: 28-2590 A THE BRISTOL
Project/Phase: Wallaceton / 3

FRAMING

Invoice	Qty.	Description
1147 345,661 23Feb23 **	1	Cold Cellar - COLD CELLAR - UPG SKETCH # 1 CONCRETE DRAIN-Notify; DRYWALL-Notify; ELECTRICAL-Supply and install light and switch; FORMING-Notify; FRAMING-Notify; INTERIOR TRIM-Supply and install metal insulated slab door including hardware
1147 346,366 23Feb23 **	1	GREAT ROOM - FIREPLACE AND MANTLE - BUILT OUT WALL ABOVE FIREPLACE TO CEILING SKETCH # 2 DRYWALL-notify; ELECTRICAL-notify; FRAMING-notify; HEATING/AIR CONDITIONING-notify; INTERIOR TRIM-notify; PAINTING-notify
1147 343,217 23Feb23 **	1	- CABINETS - OPT. BUILT IN - VIKING II/III - UPG SKETCH # 3 DRYWALL-Notify; FRAMING-Modify Bulkhead; GRANITE-delete partial countertop due to Built-in; PAINTING-

GRANITE

Invoice	Qty.	Description
1147 314,277 23Feb23	1	KITCHEN - GRANITE - GRANITE CUTOUT W/ STRAIGHT EDGE POLISH TO ACCOMMODATE COOK TOP SKETCH # 3 SEE SPECS
1147 343,217 23Feb23 **	1	- CABINETS - OPT. BUILT IN - VIKING II/III - UPG SKETCH # 3 DRYWALL-Notify; FRAMING-Modify Bulkhead; GRANITE-delete partial countertop due to Built-in; PAINTING-

HARDWOOD

Invoice	Qty.	Description
1147 314,351 23Feb23 **	3	- PAINT - STAIN STAIR LANDING IN SAMBUCCA. LANDING OVER 25 SQ.FT. EACH HARDWOOD-Supply and Install smooth UNFINISHED pre-sanded red oak at stair landing(s)
1147 345,977 23Feb23	1	KITCHEN / BREAKFAST - HARDWOOD - VINTAGE 3 1/4 IN - KITCHEN / BREAKFAST - UPG CABINETS-Raise Cabinet; CERAMICS-Delete Std Ceramics

HEATING / AIR CONDITIONING

Invoice	Qty.	Description
1147 314,340 23Feb23	1	KITCHEN - HEATING/AIR - ROUGH-IN GAS LINE FOR GAS STOVE AT MAIN FLOOR (SEE SPECS) (HOOK-UP NOT INCLUDED) LEAVE STANDARD 120 VOLT ELECTRICAL OUTLET ON A SEPARATE CIRCUIT. * SPECIFY IF STANDARD 220V WILL STAY OR BE RELOCATED RELOCATE STD 220V TO BUILT IN OVEN LOCATION SKETCH # 3 ELECTRICAL-Notify
1147 346,366 23Feb23 **	1	GREAT ROOM - FIREPLACE AND MANTLE - BUILT OUT WALL ABOVE FIREPLACE TO CEILING SKETCH # 2 DRYWALL-notify; ELECTRICAL-notify; FRAMING-notify; HEATING/AIR CONDITIONING-notify; INTERIOR TRIM-notify; PAINTING-notify



CONSTRUCTION SUMMARY

Lot: 351
Model: 28-2590 A THE BRISTOL
Project/Phase: Wallaceton / 3

INTERIOR TRIM AND DOORS

Invoice	Qty.	Description
1147 345,661 23Feb23 **	1	Cold Cellar - COLD CELLAR - UPG SKETCH # 1 CONCRETE DRAIN-Notify; DRYWALL-Notify; ELECTRICAL-Supply and install light and switch; FORMING-Notify; FRAMING-Notify; INTERIOR TRIM-Supply and install metal insulated slab door including hardware
1147 346,366 23Feb23 **	1	GREAT ROOM - FIREPLACE AND MANTLE - BUILT OUT WALL ABOVE FIREPLACE TO CEILING SKETCH # 2 DRYWALL-notify; ELECTRICAL-notify; FRAMING-notify; HEATING/AIR CONDITIONING-notify; INTERIOR TRIM-notify; PAINTING-notify

PAINTING

Invoice	Qty.	Description
1147 314,351 23Feb23	3	- PAINT - STAIN STAIR LANDING IN SAMBUCCA. LANDING OVER 25 SQ.FT. EACH HARDWOOD-Supply and Install smooth UNFINISHED pre-sanded red oak at stair landing(s)
1147 346,366 23Feb23 **	1	GREAT ROOM - FIREPLACE AND MANTLE - BUILT OUT WALL ABOVE FIREPLACE TO CEILING SKETCH # 2 DRYWALL-notify; ELECTRICAL-notify; FRAMING-notify; HEATING/AIR CONDITIONING-notify; INTERIOR TRIM-notify; PAINTING-notify
1147 343,217 23Feb23 **	1	- CABINETRY - OPT. BUILT IN - VIKING II/III - UPG SKETCH # 3 DRYWAL-Notify; FRAMING-Modify Bulkhead; GRANITE-delete partial countertop due to Built-in; PAINTING-

THE BRISTOL

ELEVATION A & B | 2,590 SQ. FT.

706 sq. ft. of opt. finished Lower Level

WALLACETON
EST. 1870

28-2590 ELEV. A

Sketch # 1

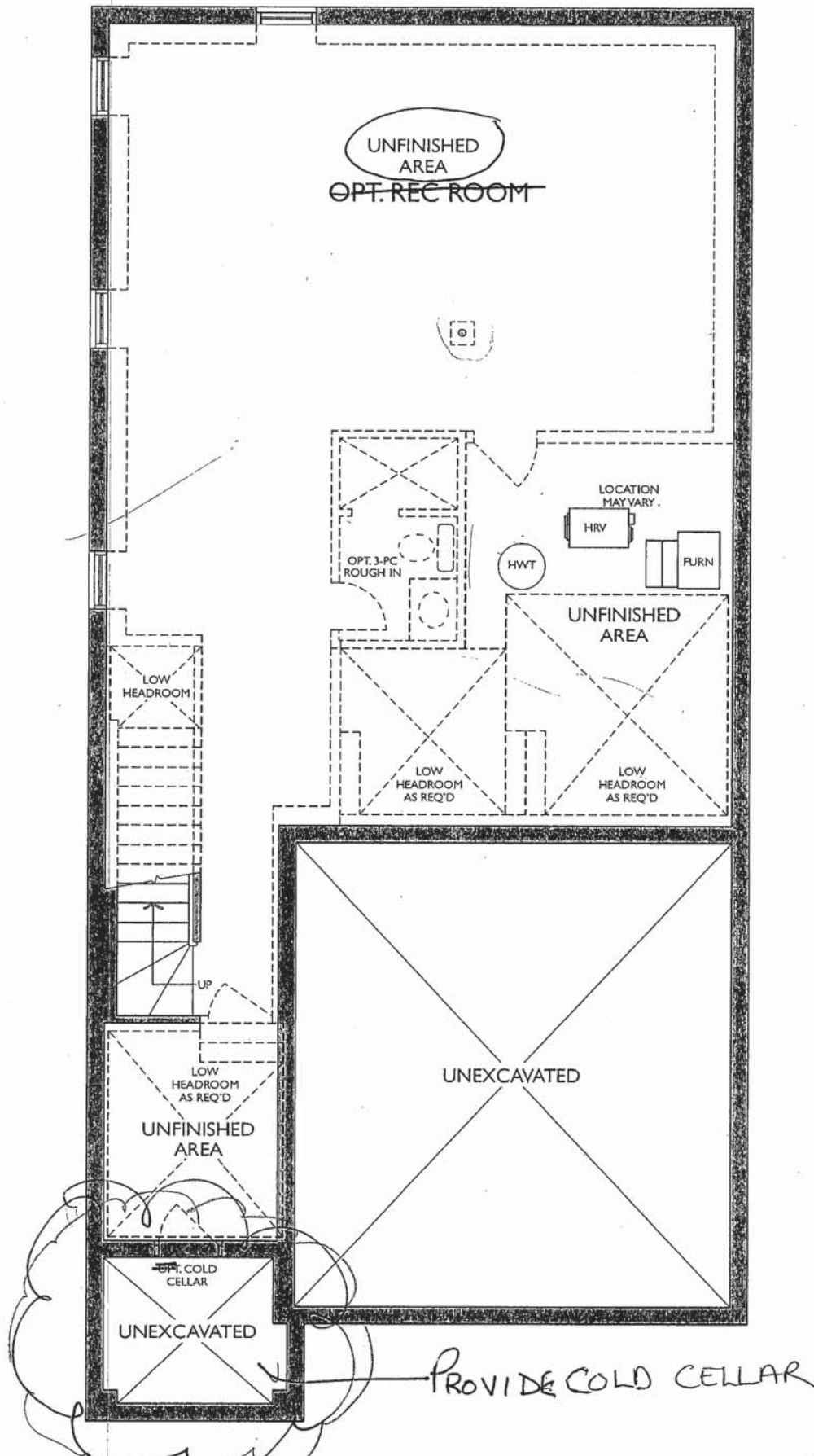

LOWER LEVEL
ELEVATION A

THE BRISTOL

ELEVATION A & B | 2,590 SQ. FT.

706 sq. ft. of opt. finished Lower Level

WALLACETON
EST. 1870

28-2590 ELEV. A

Sketch # 2

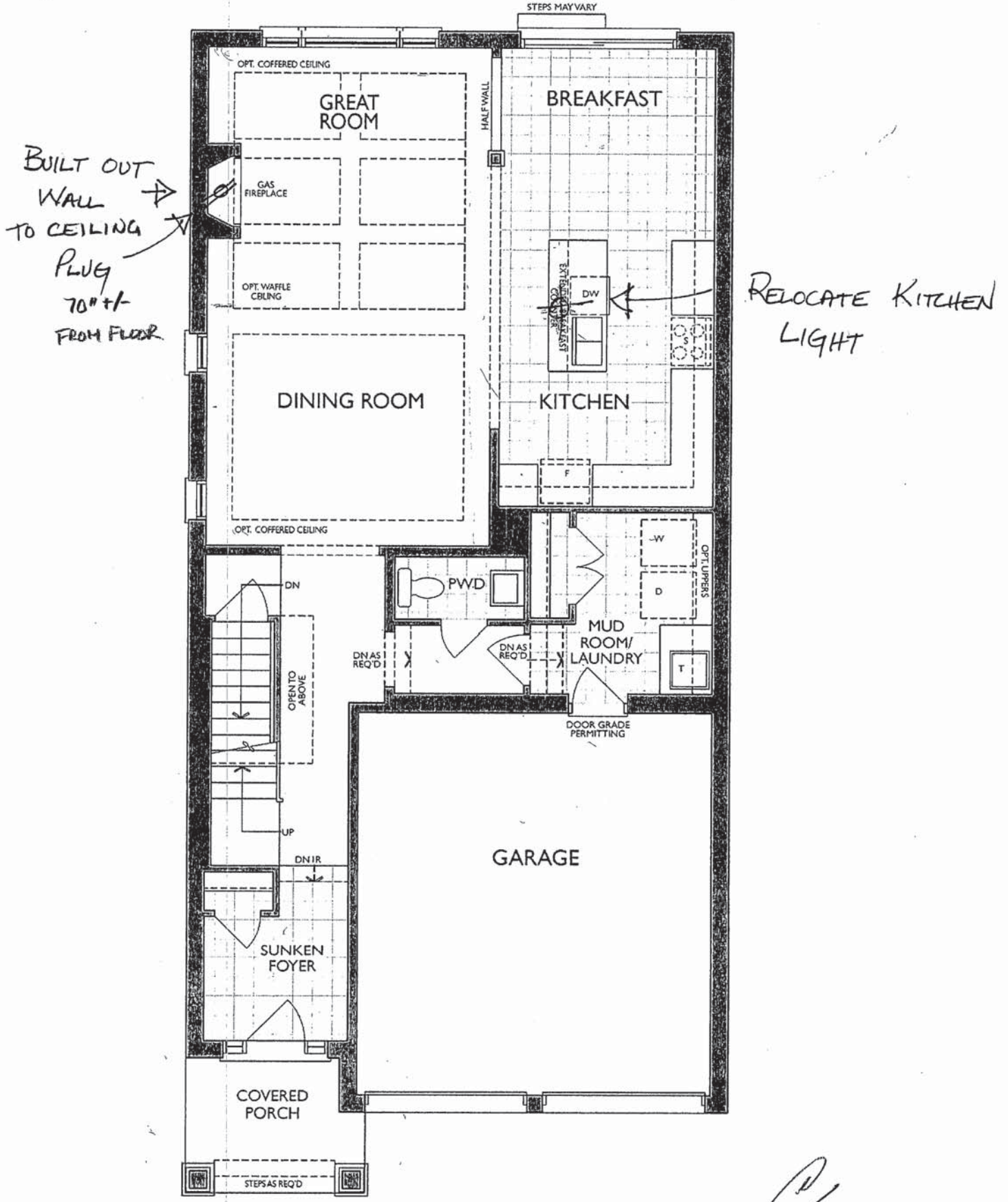

MAIN FLOOR
ELEVATION A

UPGRADE KITCHEN - BUILT-IN APPLIANCES:
 - 30" COOKTOP POTS & PANS
 - 30" WALL OVEN

Sketch # 3

Project: Wallaceton
 Unit: 351 Phase: 3
 Model: 28-2590 A THE BRISTOL

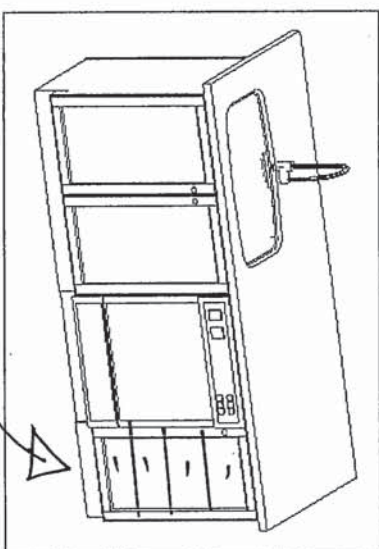
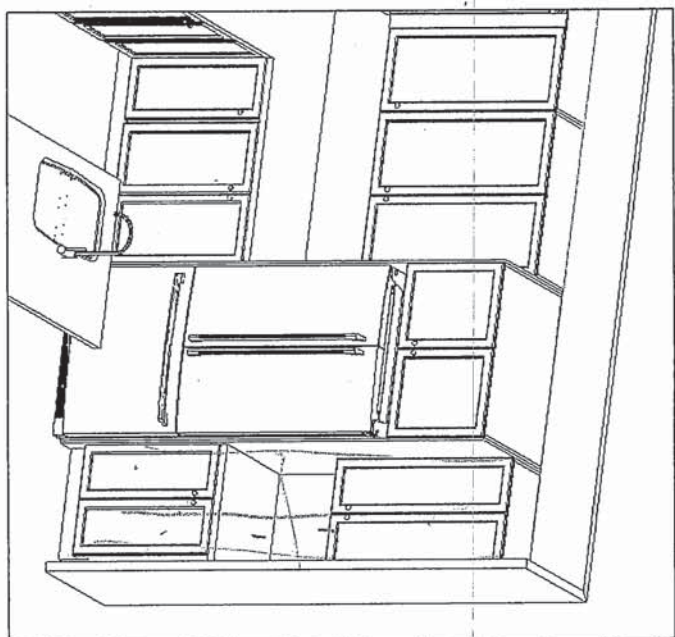
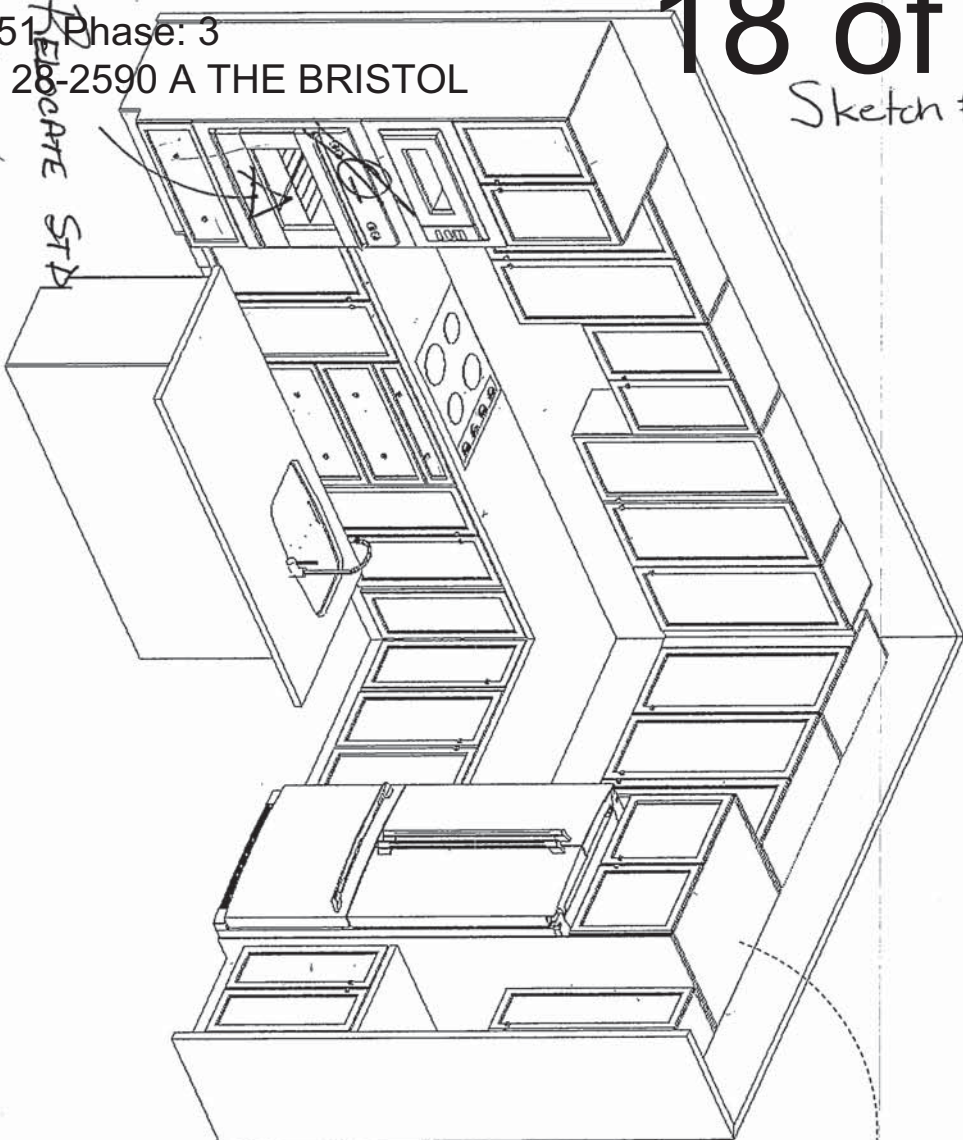

RELOCATE BANK
 OF DRAWERS

4/29/2022



FRENDEL
 KITCHENS LIMITED
 1390 Showston Drive, Mississauga, ON L4W 1C5

HEATHWOOD HOMES
 WALLACETON, KITCHENER ON
 MODEL: 28-2590 (3403)

STANDARD CONTRACT INCLUDES:

Appliance Openings

- Hood Opening: 30" W Bullder hood
- Fridge Opening: 37 3/8" W X 73 3/8"
- Fridge cabinet & gables: 66cm Deep
- Stove Opening: 30" Freestanding
- Dishwasher Opening: 24"

Standard Kitchens Scope:

- 100cm H wall cabinets
- Std. Blumotion Hinges- **soft close**
- Std. Metabox Drawers- **not soft close**
- Min 40cm W drawer
- Base pie cut corner cabinets
- Backing on all cabinets
- Countertop by others
- Upgrade applied paneled fridge & dishwashers supply only (appliance hardware by others)

Standard Vanity & Laundry Scope:

- Powder by others, pedestal
- Master Ens. - Top by others
- Remaining vanities inc. laminate top
- Std. Blum Hinges- **not soft close**
- Std. Metabox Drawers- **not soft close**
- Master Ens: Top drawers(Sink Full height)
- Mains: Full height doors (top drawers added if Masters can't accommodate)
- Optional laundry base & wall cabinets

THIS DRAWING IS FOR DESIGN PURPOSES ONLY.
 IT IS NOT AN EXACT RENDITION.

THE BRISTOL

ELEVATION A & B | 2,590 SQ. FT.

706 sq. ft. of opt. finished Lower Level

WALLACETON
EST. 1870

28-2590 ELEV. A

Sketch #4

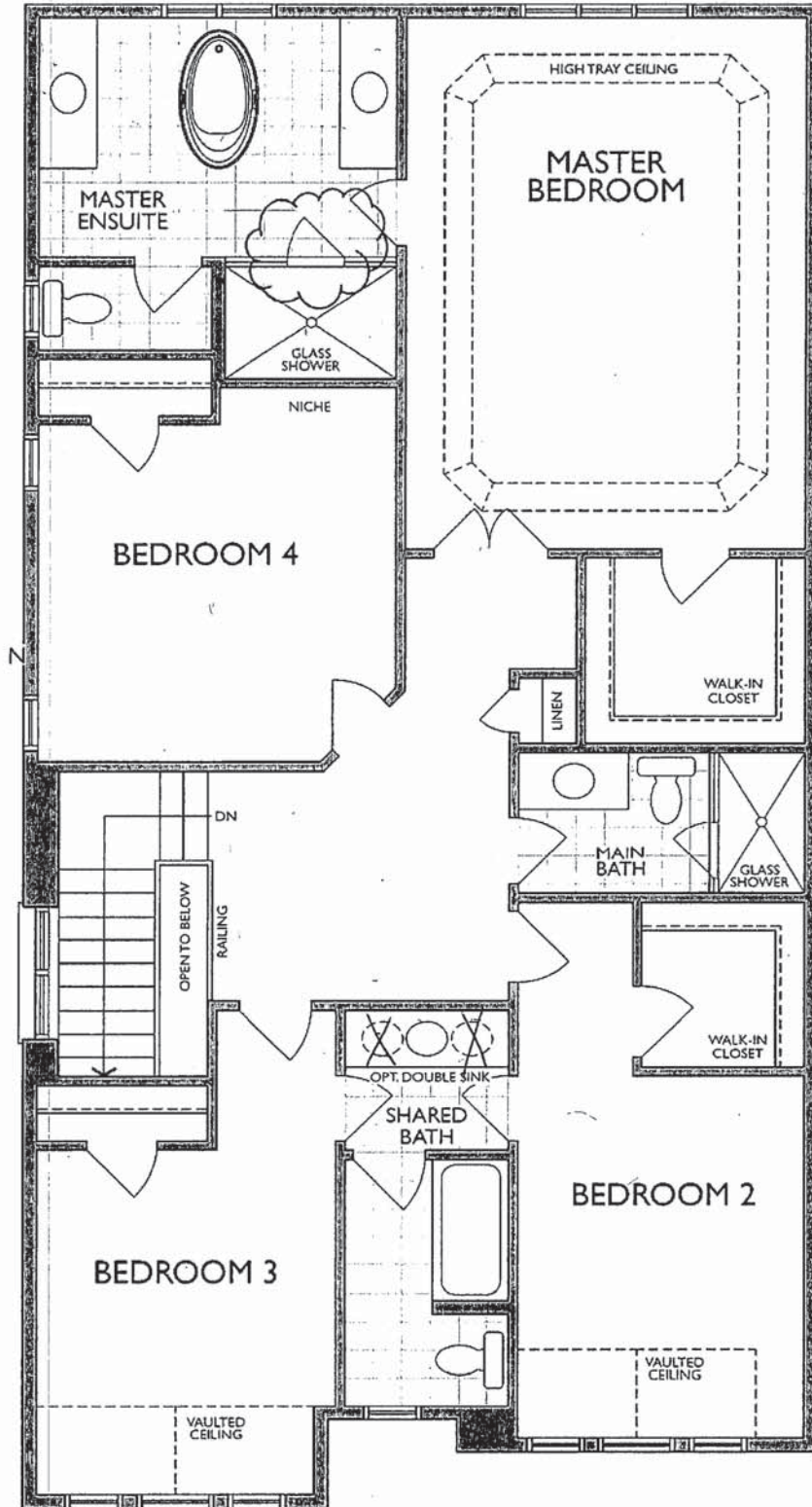

SECOND FLOOR
ELEVATION A

*Master Ensuite Shower Door Swing Changed

Sketch # 5

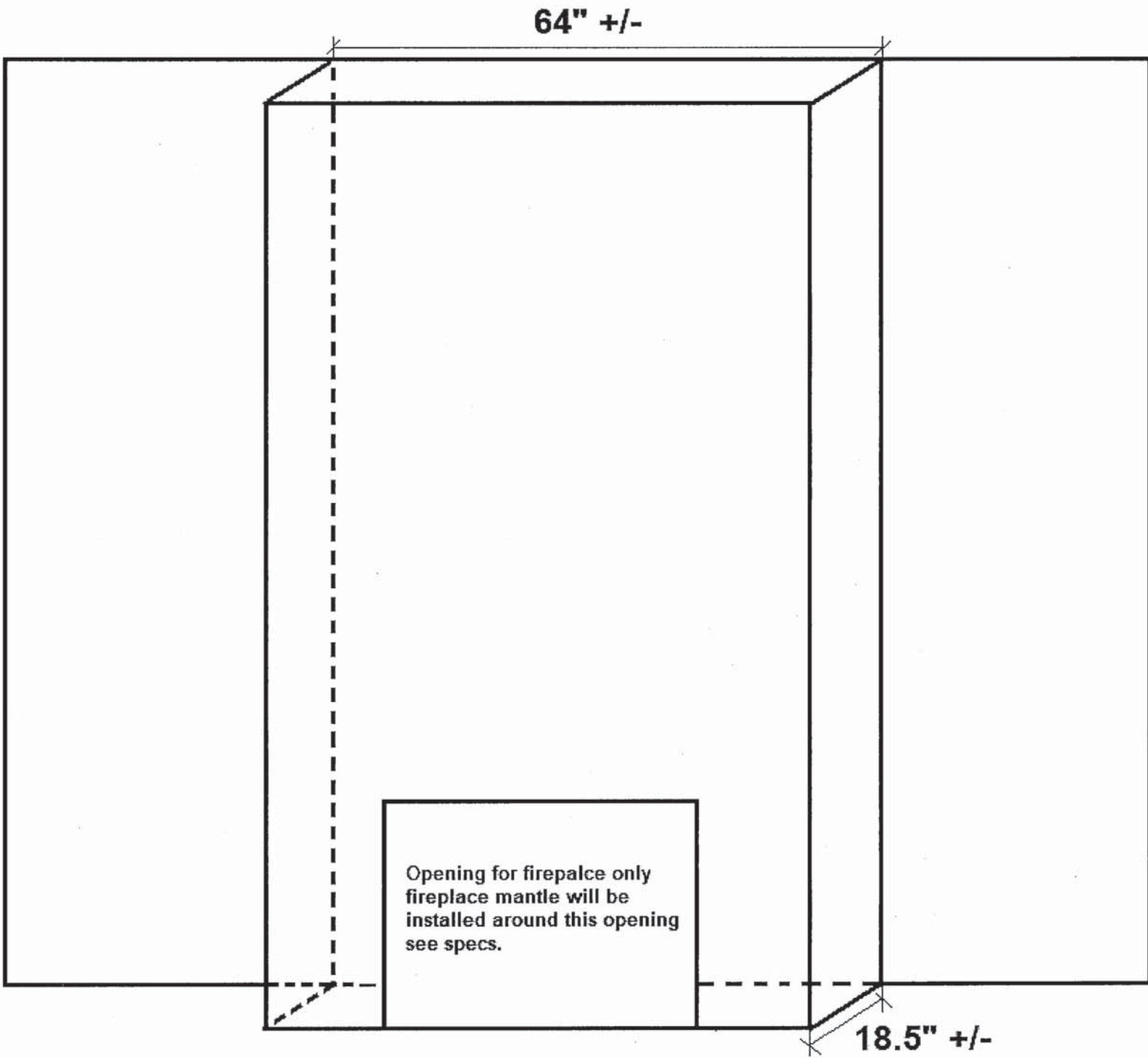

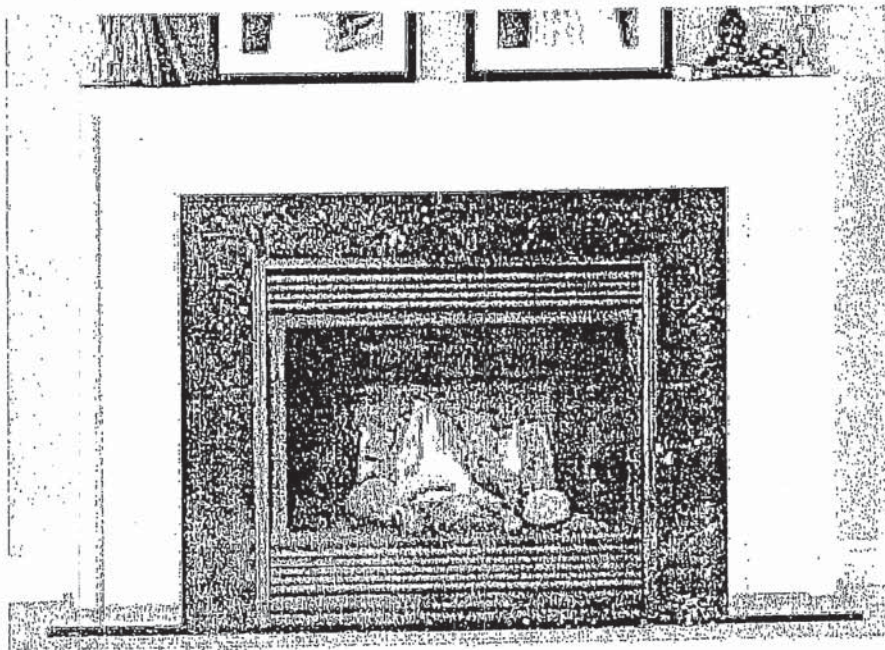

NEAS NF17 Mantel .

Reginox

ND1831UA/9

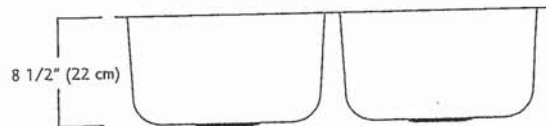
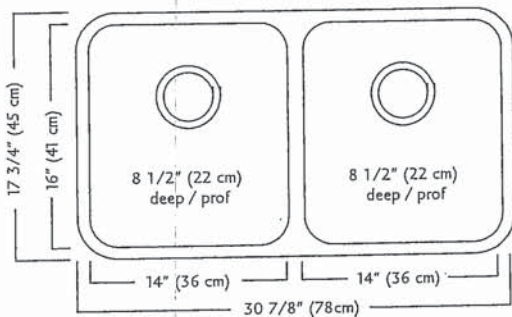
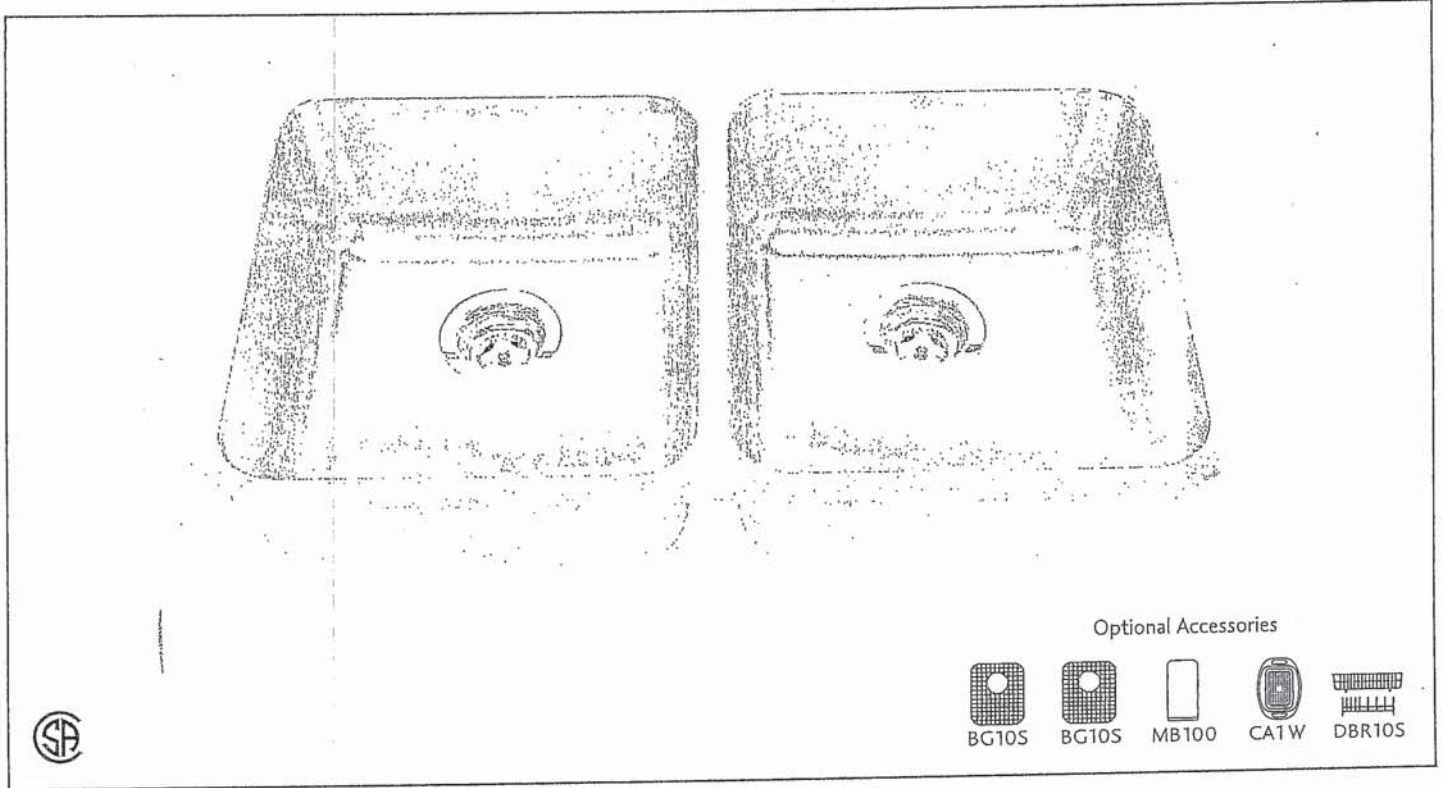

ND1831UA/9 SPECIFICATION

Model ND1831UA/9 is a double (two equal size) bowl undermount sink manufactured by Franke Kindred Canada Limited from 18 gauge stainless steel. Product has silk finished rims and linear brush finished bowls. Sink is fully undercoated. Basket strainer waste fittings (3 1/2", 89 mm) are included. Sink is backed with a limited lifetime warranty.

- O.D. 17 3/4" x 30 7/8" x 8 1/2" (45 x 78 x 22 cm)
- Recommended for minimum 36" cabinet

Franke Kindred Canada Limited
 P.O. Box 190, 1000 Franke Kindred Road, Midland, Ontario, Canada, L4R 4K9 Phone: 866-687-7465 Fax: 800-361-8408



Specifications

FAUCET DESCRIPTION

- Reflex™ pulldown system offers smooth operation, easy movement and secure docking
- Power Clean™ spray technology
- Metal construction with various finishes identified by suffix
- Quick connect installation
- Pulldown spray with 68" braided hose
- Flexible supply lines with 3/8" compression fittings
- High arc spout provides height and reach to fill or clean large pots while pulldown wand provides the maneuverability for cleaning or rinsing
- 360° rotating spout
- Faucet designed for handle to be mounted on right side only

OPERATION

- Lever style handle
- Temperature controlled by 100° arc of handle travel
- Operates with less than 5 lbs. of force
- Operates in stream or spray mode in the pullout or retracted position

FLOW

- Flow is limited to 1.5 gpm (5.7 L/min) max at 60 psi

CARTRIDGE

- 1255™ Duralast™ cartridge

STANDARDS

- Third party certified to IAPMO Green, ASME A112.18.1/CSA B125.1 and all applicable requirements therein including NSF 61/9G & 372
- Meets CalGreen and Georgia SB370 requirements
- Complies with California Proposition 65 and with the Federal Safe Drinking Water Act
- The backflow protection system in the device consists of two independently operating check valves, a primary and a secondary which prevent backflow

- ADA for lever handle

WARRANTY

- Lifetime limited warranty against leaks, drips and finish defects to the original homeowner
 - 10 year limited warranty when used in a multifamily installation
 - 5 year limited warranty when used in a commercial installation
- Visit www.moen.com/support for complete details and limitations

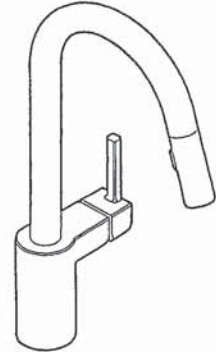

ALIGN™
 Single Handle High Arc
 Pulldown Kitchen Faucet

Models: 7565 series

NOTE: THIS FAUCET IS DESIGNED TO BE INSTALLED THROUGH 1 HOLE, 1-1/2" (38mm) MIN. DIA. (OPTIONAL 3-HOLE ESCUTCHEON 141002 AVAILABLE)

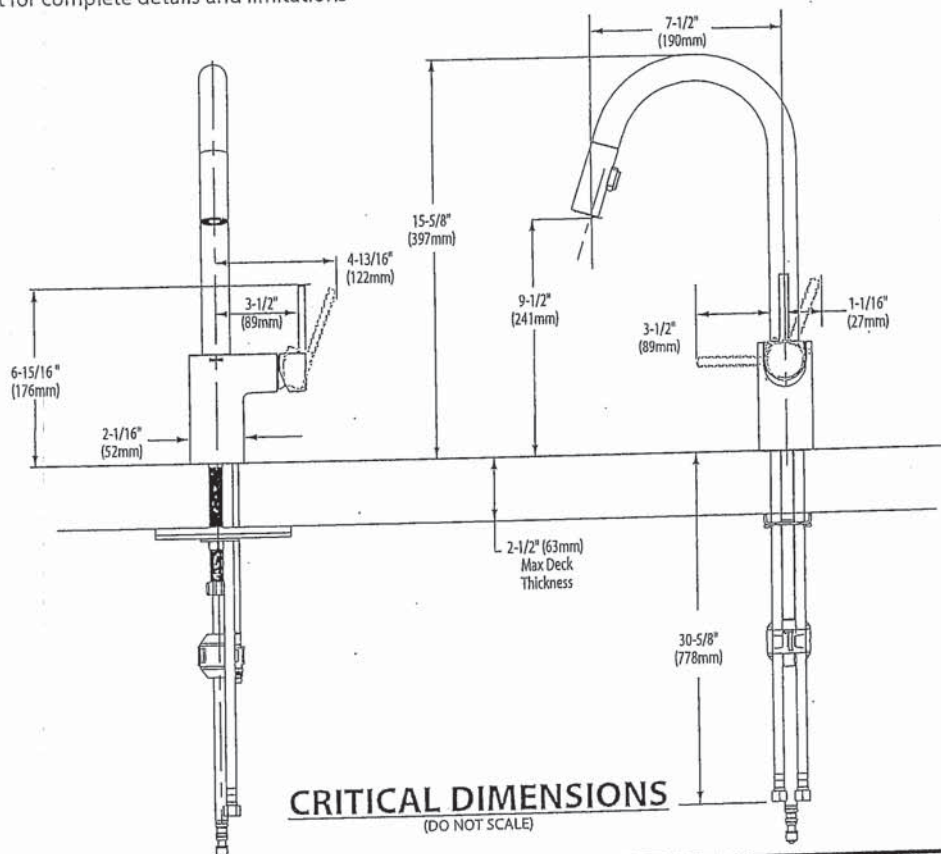

FOR MORE INFORMATION CALL: 1-800-BUY-MOEN
www.moen.com



BARRIER FREE (ABOVE COUNTER OR DROP-IN ONLY)

BOULEVARD®
PEDESTAL SINK
VITREOUS CHINA

BOULEVARD® PEDESTAL SINK

- ~~0641.800~~ Faucet holes on 8" (203mm) centers (illustrated)
STD 0641.400 Faucet holes on 4" (102mm) centers
 ~~0641.100~~ Center hole only

- Classic styled rectangular pedestal lavatory
- Vitreous china
- Rear overflow
- Supplied with mounting kit
- Right Height® for greater comfort during use
- Faucet ledge with large deck area (faucet not included)
- Design coordinates with Boulevard® Toilet
- Basin has flat bottom to also allow use as an above counter sink or a drop-in sink (with u-shaped cut out)

Nominal Dimensions:

24" x 19" x 35-1/2"
(610 x 483 x 902mm)

- 0641.008 Pedestal top-8" (203mm) centers
- 0641.004 Pedestal top-4" (102mm) centers
- 0641.001 Pedestal top-center hole only
- 0010.000 Pedestal only

Bowl sizes:

17" (432mm) wide,
12-1/2" (318mm) front to back,
5" (127mm) deep

Compliance Certifications -

Meets or Exceeds the Following Specifications:

- ASME A112.19.2 - 2008/CSA B45.1-08

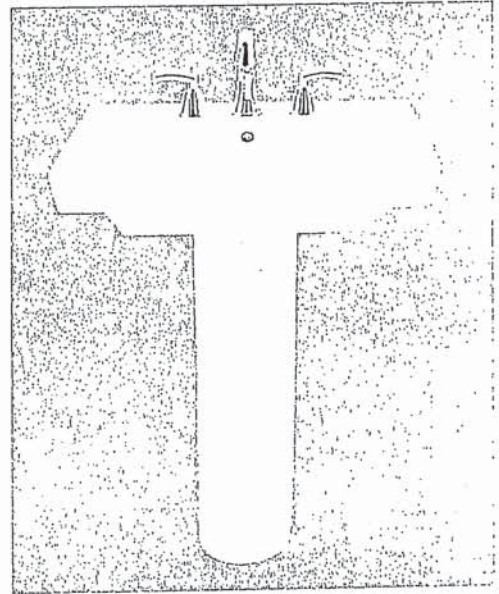

SEE REVERSE FOR ROUGHING-IN DIMENSIONS

To Be Specified:

- Color: White Linen
- Faucet Finish:
- Supplies:
- 1-1/4" Trap:
- Nipple:

* See faucet section for additional models available

American Standard

**BOULEVARD®
 PEDESTAL SINK**
 VITREOUS CHINA

 BARRIER FREE (ABOVE COUNTER OR DROP-IN ONLY)

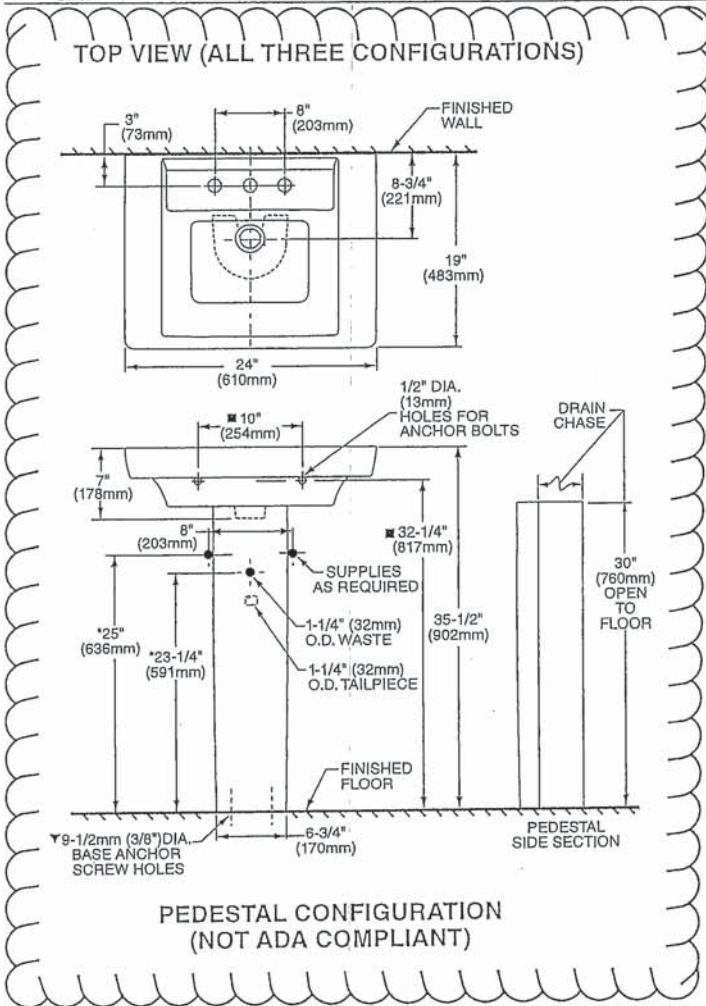

ABOVE COUNTER CONFIGURATION

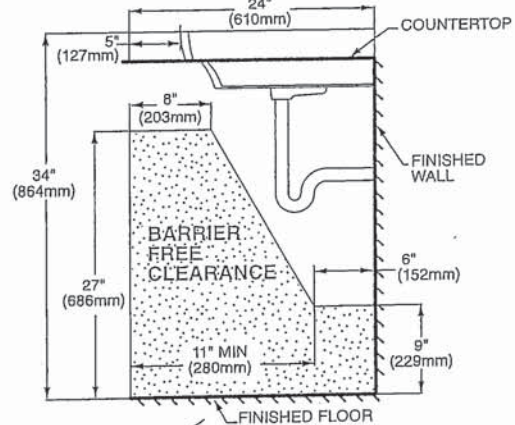
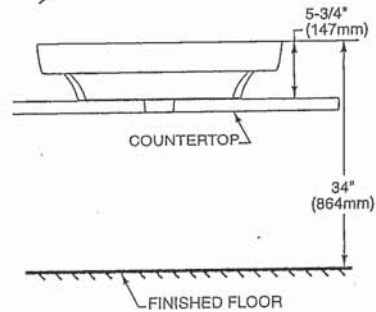

DROP-IN SINK CONFIGURATION

 ABOVE COUNTER AND DROP-IN SINK CONFIGURATIONS MEET THE AMERICANS WITH DISABILITIES ACT GUIDELINES AND ANSI A117.1 ACCESSIBLE AND USABLE BUILDINGS AND FACILITIES - CHECK LOCAL CODES.
 Top of sink installed at 34" (864mm) height from finished floor.
 Sink installed 5" (127mm) minimum from front edge of countertop.
 Provide 27" (686mm) knee clearance area.

NOTES:
 * DIMENSIONS SHOWN FOR LOCATION OF SUPPLIES AND "P" TRAPS ARE SUGGESTED.
 ▼ PEDESTAL ANCHORING SCREWS NOT INCLUDED.
 ■ SUITABLE FOR REINFORCEMENT ONLY. ACTUAL DIMENSIONS MUST BE TAKEN FROM FIXTURE.
 FITTING NOT INCLUDED AND MUST BE ORDERED SEPARATELY.
 PROVIDE SUITABLE REINFORCEMENT FOR ALL WALL SUPPORTS.
 INSTALLATION INSTRUCTIONS SUPPLIED WITH LAVATORY.

IMPORTANT: Dimensions of fixtures are nominal and may vary within the range of tolerance established by ANSI Standard A112.19.2. These measurements are subject to change or cancellation. No responsibility is assumed for use of superseded or voided pages.

American Standard

Style That Works Better

 BARRIER FREE

OVALYN™
UNDERCOUNTER SINK
VITREOUS CHINA

OVALYN™ UNDERCOUNTER SINK

- Classic oval undermount sink
- Made from vitreous china
- Front overflow
- Supplied with mounting kit (047194-0070A) and template

- 0495.221 Unglazed rim**
435 x 359mm
(17-1/8" x 14-1/8")
- 0495.300 Glazed underside**

Bowl size:

382mm (15-1/16") wide
306mm (12-1/16") front to back
140mm (5-1/2") deep

- 0496.221 Unglazed rim**
489 x 413mm
(19-1/4" x 16-1/4")

- 0496.300 Glazed underside**

Bowl size:

432mm (17") wide
356mm (14") front to back
140mm (5-1/2") deep

- 0497.221 Unglazed rim**
546 x 441mm
(21-1/2" x 17-3/8")

- 0497.300 Glazed underside**

Bowl size:

483mm (19") wide
391mm (15-3/8") front to back
140mm (5-1/2") deep

Compliance Certifications -

Meets or Exceeds the Following Specifications:

- ASME A112.19.2M for Vitreous China Fixtures
- CAN/CSA B45 series

To Be Specified:

- Color: White Bone Linen
 Silver Fawn Beige Black

- Faucet*:
- Faucet Finish:
- Supplies:
- 1-1/4" Trap:

* See faucet section for additional models available

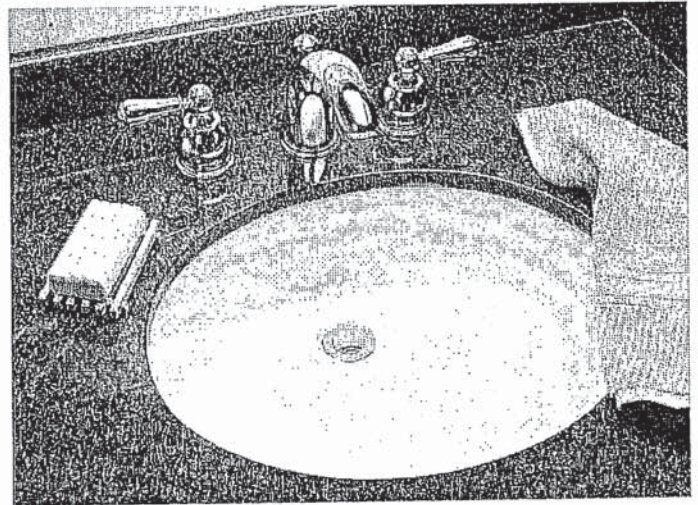

STD Master Ensuite Undermount SINGLES

SEE REVERSE FOR ROUGHING-IN DIMENSIONS

American Standard
 Style That Works Better

OVALYNT™ UNDERCOUNTER SINK VITREOUS CHINA

BARRIER FREE

0496/0497

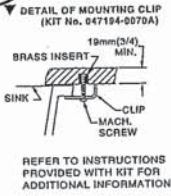
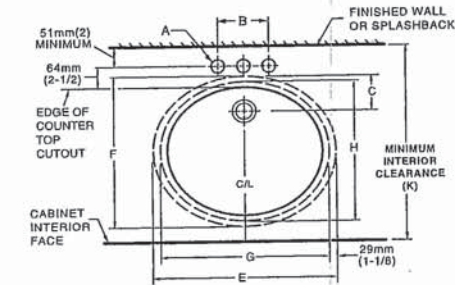

NOTES:
 * DIMENSIONS SHOWN FOR LOCATION OF SUPPLIED AND "P" TRAP ARE SUGGESTED.
 ▼ UNDERCOUNTER MOUNTING KIT SUPPLIED WITH SINK. PLEASE NOTE MINIMUM INTERIOR CLEARANCE DIMENSION (K). FITTINGS NOT INCLUDED AND MUST BE ORDERED SEPARATELY. USE ENCLOSED TEMPLATE FOR COUNTERTOP CUTOUT SEALING COMPOUND SUPPLIED BY OTHERS.

IMPORTANT: Dimensions of fixtures are nominal and may vary within the range of tolerances established by ANSI Standard A112.19.2. These measurements are subject to change or cancellation. No responsibility is assumed for use of superseded or voided pages.

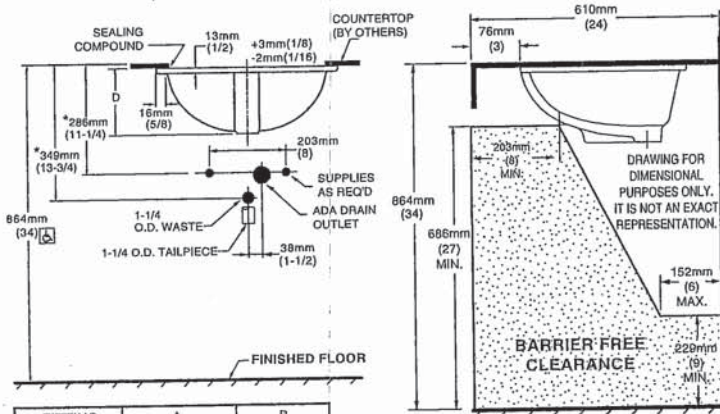

MEETS THE AMERICANS WITH DISABILITIES ACT GUIDELINES AND ANSI A117.1 ACCESSIBLE AND USEABLE BUILDINGS AND FACILITIES - CHECK LOCAL CODES.

Countertop 864mm (34") from finished floor. Lavatory installed 76mm (3") from front edge of countertop. Countertop thickness to be 25mm (1") maximum.

FITTING	A	B
CENTERSET	1-1/4 (32mm)	4 (102mm)
SPREAD	1-3/8 (35mm)	8 (203mm)

CAT. NO.	E	F	G	H	C	D	J	K
0496.221	489mm (19-1/4)	413mm (16-1/4)	432mm (17)	356mm (14)	103mm (4-1/16)	182mm (7-3/16)	16mm (5/8)	500mm (19-11/16)
0497.221	546mm (21-1/2)	441mm (17-3/8)	483mm (19)	391mm (15-3/8)	95mm (3-3/4)	191mm (7-1/2)	19mm (3/4)	534mm (21-1/16)

0495

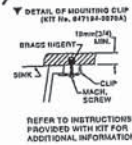
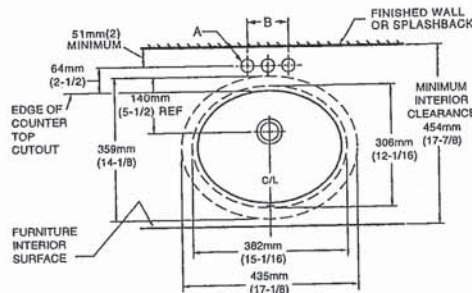

FITTING	A	B
CENTERSET	1-1/4 (32mm)	4 (102mm)
SPREAD	1-3/8 (35mm)	8 (203mm)

NOTES:
 USE ENCLOSED TEMPLATE FOR COUNTER TOP CUTOUT. FITTINGS NOT INCLUDED WITH FIXTURE AND MUST BE ORDERED SEPARATELY.
 * DIMENSIONS SHOWN FOR LOCATION OF SUPPLIED AND "P" TRAP ARE SUGGESTED.
 ▼ UNDERCOUNTER MOUNTING KIT SUPPLIED WITH SINK. PLEASE NOTE MINIMUM INTERIOR CLEARANCE DIMENSION (K). SEALING COMPOUND SUPPLIED BY OTHERS.

IMPORTANT: Dimensions of fixtures are nominal and may vary within the range of tolerances established by ANSI Standard A112.19.2. These measurements are subject to change or cancellation. No responsibility is assumed for use of superseded or voided pages

MEETS THE AMERICANS WITH DISABILITIES ACT GUIDELINES AND ANSI A117.1 ACCESSIBLE AND USEABLE BUILDINGS AND FACILITIES - CHECK LOCAL CODES.

Countertop 864mm (34") from finished floor. Lavatory installed 51mm (2") from front edge of countertop. Countertop thickness to be 25mm (1") maximum.

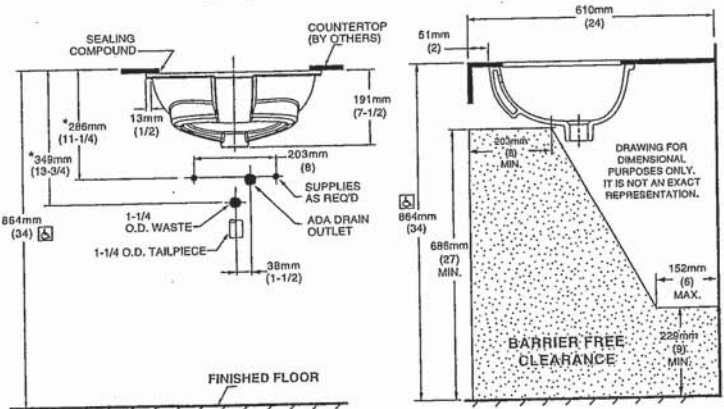

American Standard

BARRIER FREE

COLONY™
 COUNTERTOP SINK
 VITREOUS CHINA

COLONY COUNTERTOP SINK

- Vitreous china
- Self-rimming
- Front overflow
- Supplied with template
- Faucet deck
 (Faucet shown not included)

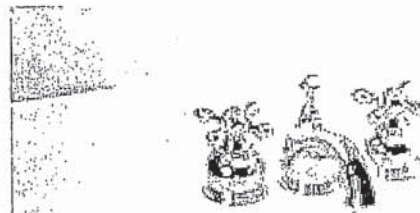

- 0346 803
 Faucet holes on 203mm (8") centres
- 0346 403 (Illustrated)
 Faucet holes on 102mm (4") centres
- 0346 001
 Centre hole only

Nominal Dimensions:
 521 x 448mm (20-1/2" x 17-5/8")

Bowl sizes:
 422mm (16-5/8") wide, 279mm (11") front to back, 143mm (5-5/8") deep

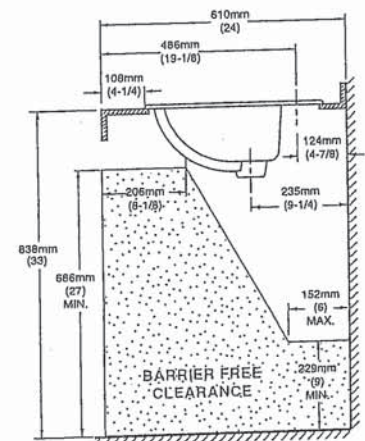
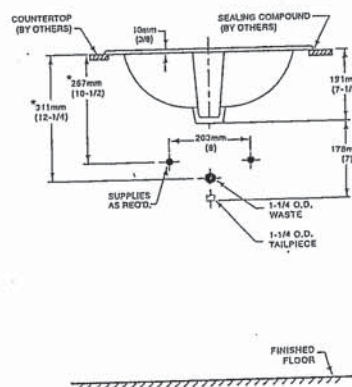
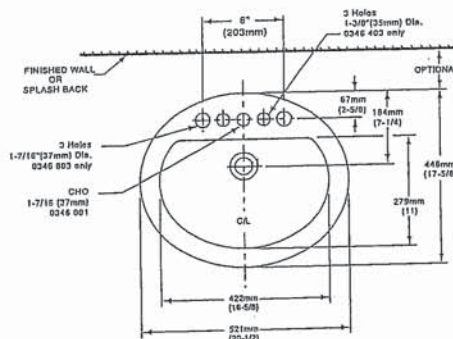

COMPLIANCE CERTIFICATIONS –
 Meets or exceeds the following Specifications:
 • ASME A112.19.2M for Vitreous China Fixtures.
 • CAN/CSA B45 Series.

To Be Specified

- Colour: White Bone Silver Gray
 Linen
- Faucet*:
- Faucet Finish:
- Supplies & Stops:
- Trap 1-1/4" (32 mm):

NOTES:
 * DIMENSIONS SHOWN FOR LOCATION OF SUPPLIES AND "P" TRAP ARE SUGGESTED. FOR COUNTERTOP CUTOUT AND INSTALLATION INSTRUCTIONS USE TEMPLATE SUPPLIED WITH SINK.
 FAUCETS NOT INCLUDED AND MUST BE ORDERED SEPARATELY.
 IMPORTANT: Dimensions of fixtures are nominal and may vary within the range of tolerances established by ANSI Standard A112.19.2.
 These measurements are subject to change or cancellation. No responsibility is assumed for use of superseded or voided pages.

* See faucet section for additional models available



DEMI™ Product Specification Sheet

Two Piece Freestanding Collection

CF2007 Two Piece Freestanding Soaker

Size: 60" x 32" x 22"
 1524 mm x 813 mm x 559 mm

PRODUCT FEATURES & BENEFITS

- Vacuum formed acrylic reinforced with fiberglass
- Scratch, stain and fade resistant high gloss finish
- Installation friendly two piece design
- Accepts deck mounted faucet
- Includes integral pop up drain and rectangular overflow
- Includes levelling feet

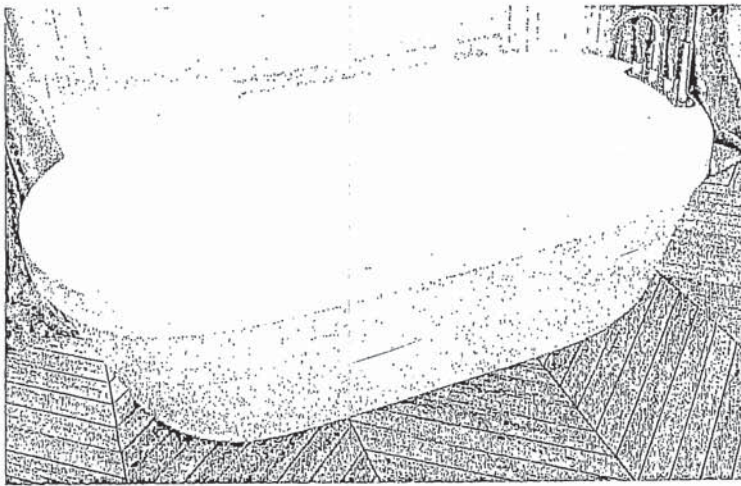

TWO PIECE ASSEMBLY

FRONT VIEW

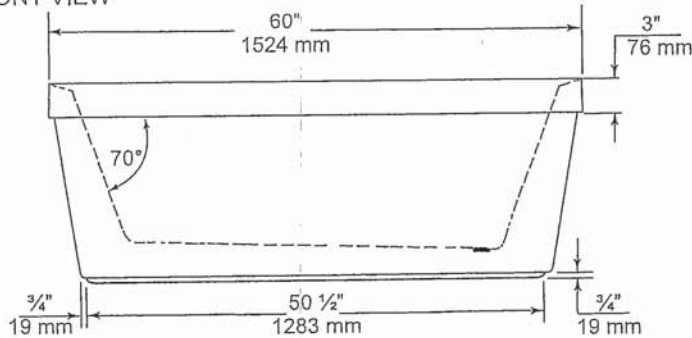

END VIEW

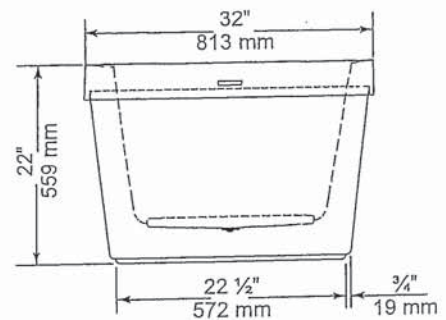

TOP VIEW

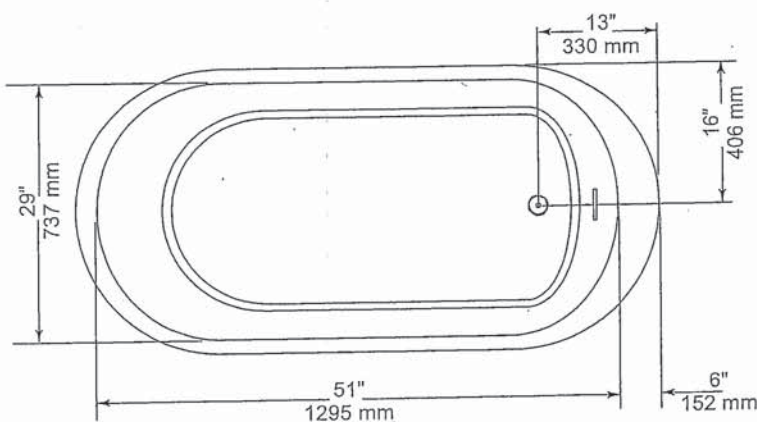

GENERAL SPECIFICATIONS

Average Weight	90 lb	41 kg
Bathing Well at bottom	43" x 20"	1092 x 508 mm
Capacity Drain to Overflow		195 litres
Water Depth Drain to Overflow	16"	406 mm
Drain Opening (dia.)	2"	51 mm
Overflow Opening	2 1/4" x 1/2"	57 x 13 mm
Drain to Floor Clearance	3 1/4"	83 mm

NOTES: Please confirm measurements on actual product to ensure proper identification. Bathtub to be installed on the floor supported by 5 self levelling feet. Adjust if required to level the bathtub for adequate drainage. Refer to installation instructions for additional information.

IMPORTANT: Dimensions of fixtures are nominal and may vary $\pm 1/4$ " (6 mm). Weight may vary ± 5 lb (2.3 kg). Drawing is not to scale. These measurements are subject to change at manufacturer's discretion.

Compliance Certifications -

Meets or Exceeds the following Specifications:

- CAN/CSA - B45 Series



American Standard

Style That Works Better

FloWise™ DUAL FLUSH ELONGATED TOILET

VITREOUS CHINA

FloWise™ DUAL FLUSH ELONGATED TOILET

2476 216

- Vitreous china
- Low-consumption Dual Flush
 Full flush 6.0 Lpf/1.3 gpf,
 Partial flush 3.0 Lpf/0.66 gpf.
- Elongated wash down bowl
- Internal trapway fully-glazed,
 2-1/4" (57mm) ballpass
- Concealed trapway bowl
- Chrome-plated top mounted
 push button actuator
- Easy to clean sanitary dam on bowl
- Includes Elongated Slow Close Seat
- 100% factory flush tested
- 2 bolt caps

Separate Component Parts:

- 3067 316 Elongated Bowl with Slow Close Seat
- 4035 216 Unlined Tank

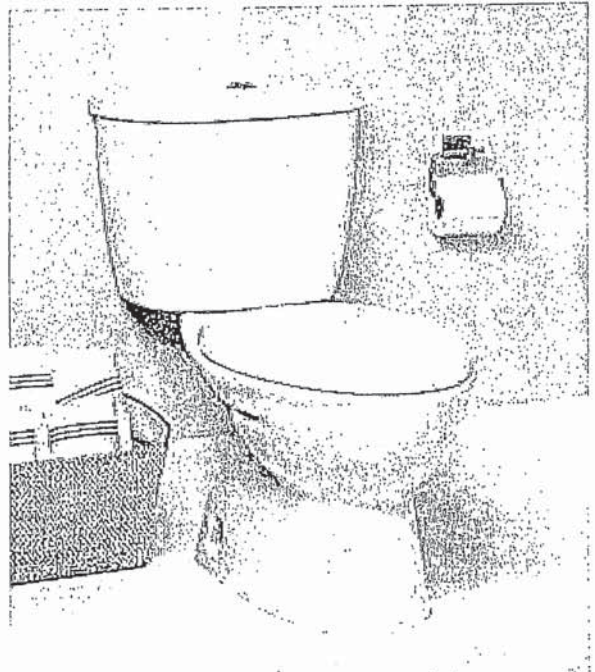

2476 516 Same as above with Lined tank

- 3067 316 Elongated Bowl
- 4035 516 Lined Tank

Nominal Dimensions:
 794 x 432 x 765mm
 (31-1/4" x 17" x 30-1/8")

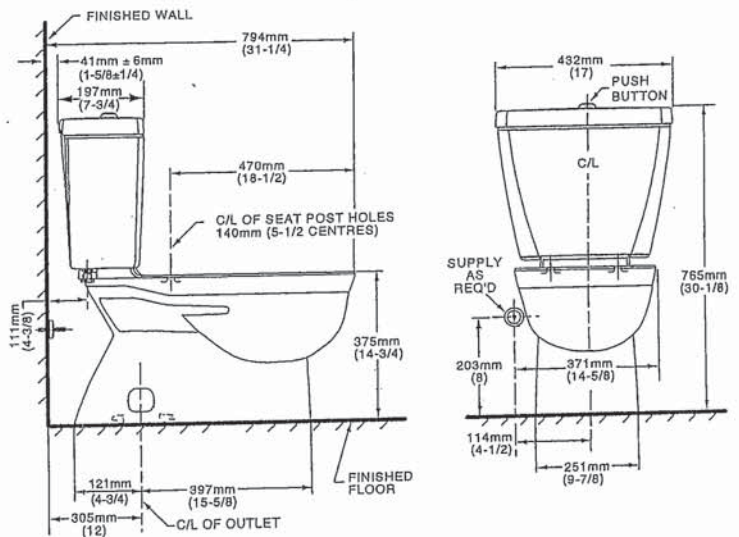

**Compliance Certifications -
 Meets or Exceeds the Following Specifications:**

- ASME A112.19.2M (and 19.6M)
- CAN/CSA B45 series

To Be Specified

- Colour: 020 White
- Supply with stop:

NOTES:
 THIS TOILET IS DESIGNED TO ROUGH-IN AT A MINIMUM DIMENSION OF 305MM (12") FROM FINISHED WALL TO C/L OF OUTLET.
 SUPPLY NOT INCLUDED WITH FIXTURE AND MUST BE ORDERED SEPARATELY.
 * DIMENSION SHOWN FOR LOCATION OF SUPPLY IS SUGGESTED.
 FOR ADDITIONAL INFORMATION REFER TO INSTALLATION INSTRUCTIONS SUPPLIED.
 IMPORTANT: Dimensions of fixtures are nominal and may vary within the range of tolerance established by ANSI Standard A112.19.2
 These measurements are subject to change or cancellation. No responsibility is assumed for use of superseded or voided pages.

UPGRADED VALUE ADDED FEATURES AT NO EXTRA CHARGE



Specifications

DESCRIPTION

- Metal construction with various finishes identified by suffix
- 16" long 3/8" tubing connections
- Includes metal or 50/50 pop-up type waste assembly where noted

OPERATION

- Pivot action lever style handle
- Temperature controlled through 180° degree arc of handle travel

FLOW

- Flow is limited to 1.5 gpm max (5.7L/min) at 60 psi

CARTRIDGE

- 1225 cartridge design
- Nonmetallic/nonferrous and stainless steel material
- Can accommodate reversed piping and back to back installations

STANDARDS

- Third party certified to WaterSense®, CSA B-125.1, ASME A112.18.1 and all applicable requirements referenced therein including NSF61/9
- Complies with California Proposition 65 and with the Federal Safe Drinking Water Act

- ADA  for lever handle

WARRANTY

- Lifetime limited warranty against leaks, drips and finish defects to the original consumer purchaser
- 5 year warranty if used in commercial installations

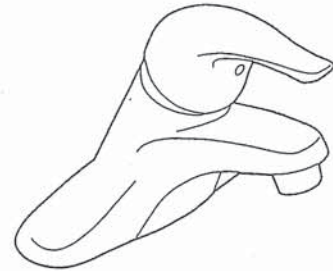

CHATEAU® Single-Handle Lavatory Faucet

with Metal Waste Assembly

Model: L4625 series

L4631BC

Bulk Packed (12 per carton):

L64624 series

with 50/50 Waste Assembly

Bulk Packed (12 per carton):

L64625 series

Less Waste

Bulk Packed (12 per carton):

L64600 series

NOTE: THIS FAUCET IS DESIGNED TO BE INSTALLED THRU 3-1" DIA. HOLES, 2" ON CENTER

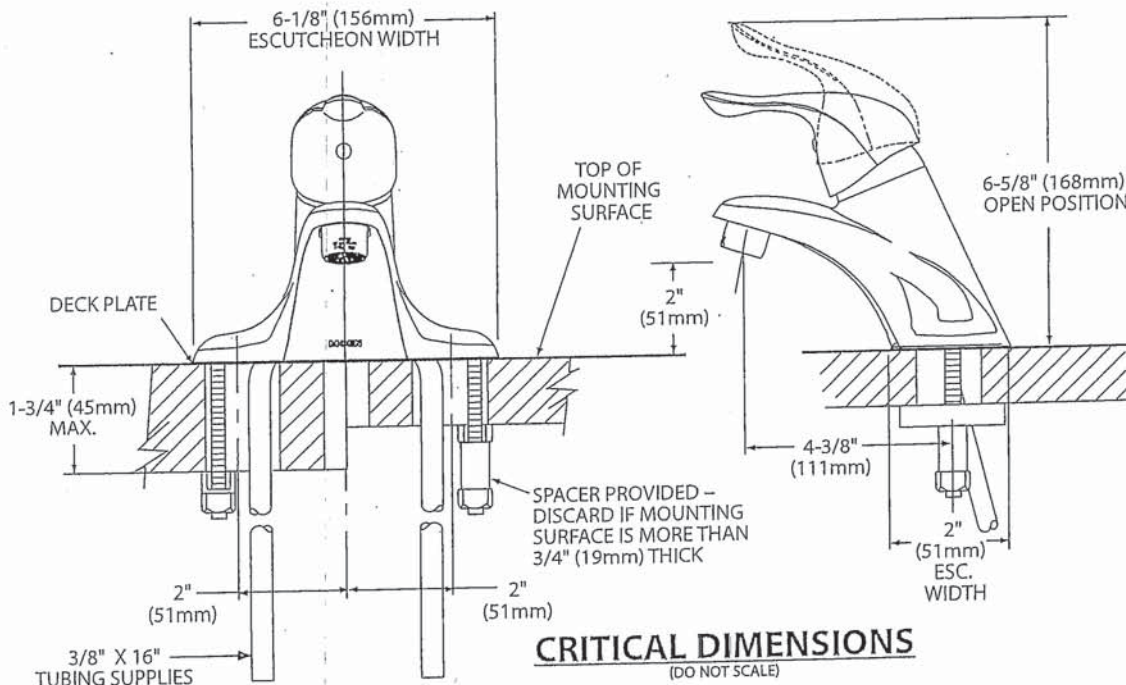

FOR MORE INFORMATION CALL: 1-800-BUY-MOEN
www.moen.com



Buy it for looks. Buy it for life.®

There is more than 1 version of this model.
 Page down to identify the version you have.

DESCRIPTION

- Metal construction with various finishes identified by suffix
- Includes non-metallic showerhead, arm, flange and non-metallic diverter tub spout

OPERATION

- Handle operates counterclockwise through a 270° arc with off at 6 o'clock and maximum hot at the 9 o'clock position. Shut off in clockwise direction
- Adjustable temperature limit stop to control maximum hot water temperature
- Pressure balancing mechanism maintains selected discharge temperature to ± 3°

FLOW

- Showerhead is limited to 2.5 gpm (9.5 L/min) at 80 psi
- EP suffix models are limited to 1.75 gpm (6.6 L/min) at 80 psi
- NH suffix models contain no showerhead

CARTRIDGE

- 1222 cartridge design
- Accommodates back to back installations
- Nonmetallic/nonferrous and stainless steel material

STANDARDS

- Third party certified to meet ASME A112.18.1/CSA B125.1 and all applicable requirements referenced therein
- EP suffix models are third party certified to WaterSense®
- ADA for lever handle

WARRANTY

- Lifetime limited warranty against leaks, drips and finish defects to the original consumer purchaser
- 5 year warranty if used in commercial installations

Specifications



**CHATEAU® POSI-TEMP®
 Single-Handle Tub/Shower Trim Kit**

- Models:** TL181 series - valve trim only
 (Bulk Packed 12 per carton)
 TL182 series - shower trim only
 (Bulk Packed 12 per carton)
 TL183 series - tub/shower trim
 (Bulk Packed 12 per carton)

- Valves:** 62300 series
 2500 series

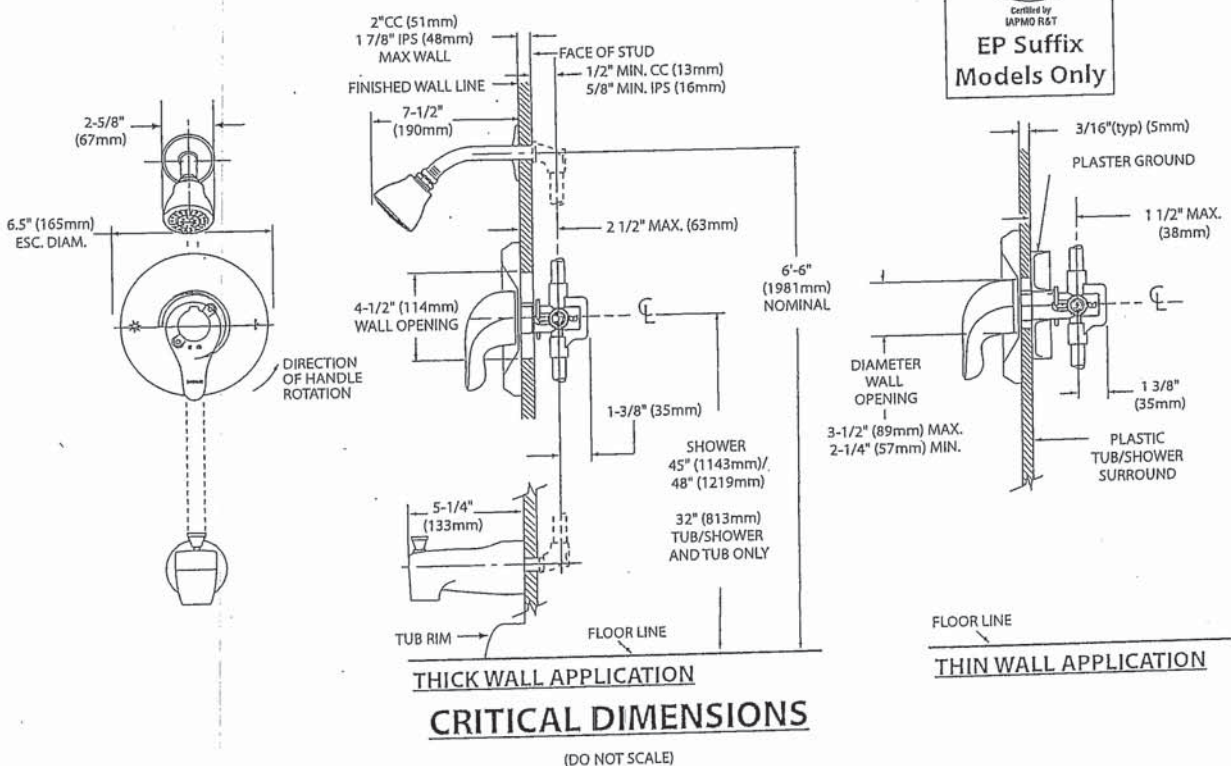

FOR MORE INFORMATION CALL: 1-800-BUY-MOEN
 www.moen.com



Specifications

DESCRIPTION

- Metal construction with various finishes identified by suffix

OPERATION

- Lever style handles with hot and cold color indicator
- Rotate hot side handle counterclockwise to open (clockwise to close) and the cold side handle (clockwise to open) and (counterclockwise to close)

STANDARDS

- Third party certified to: ASME A112.18.1/CSA B-125.1, and all applicable requirements referenced therein
- ADA  for lever handles

WARRANTY

- Lifetime limited warranty against leaks, drips and finish defects to the original homeowner
 - 10 year limited warranty when used in a multi-family installation
 - 5 year limited warranty when used in a commercial installation
- Visit www.moen.com/support for complete details and limitations

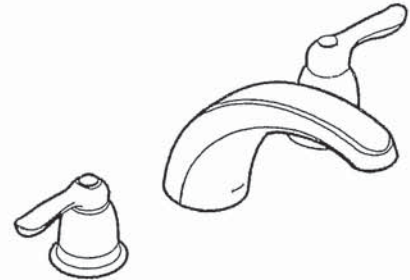

CHATEAU®
Two-Handle Garden Tub Trim

Models: T994 series

Valves: 4792, 4793, 4794, 4796, 4797, 4798

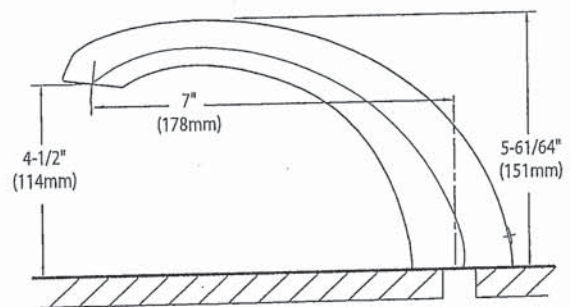
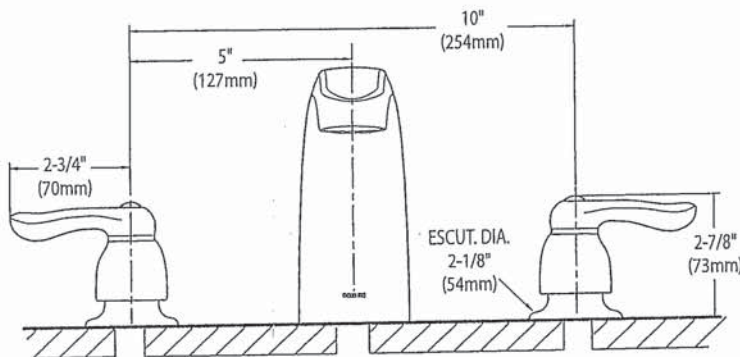

CRITICAL DIMENSIONS

(DO NOT SCALE)



SPECIFICATIONS
AV SERIES
 RANGE HOODS

HVI CERTIFIED 2100
 180 CFM/7.0 Sones @ 0.10" SP. Horizontal
 180 CFM/7.5 Sones @ 0.10" SP. Vertical

Dimensions

Overall bottom projection - 18³/₈"
 Overall top projection - 12"
 Height - 6"
 Available widths: 21", 24", 30", 36" & 42"

Hood Body

Stainless Steel: 24 gauge, grade 430 stainless steel.
 Painted: 23 gauge cold rolled commercial grade (CRCQ) steel, auto welded, coated with a baked enamel finish.

Motor

2 speed, single coil, thermally protected, permanently lubricated.
 Rated 120 volts, 60 hz. Complete with 200°C lead wires.

Lighting

Single 60 watt cook light capacity (bulb not included).

Ducting Options

Horizontal ducting: 3¹/₄"x10" (duct adapter and damper included).
 Vertical ducting: 3¹/₄"x10" (duct adapter and damper included).
 Vertical ducting: 7" round (duct adapter and damper not included).
 Ductless: removable front vent (charcoal filter not included).

Fan Blade

One piece polymeric, electronically balanced blade. 6⁵/₈" diameter with 5 paddles.

Electrical connection

Hood top - 7/8" knockout hole for use with 1/2" cable clamp
 Hood back - 7/8" knockout hole for use with 1/2" cable clamp

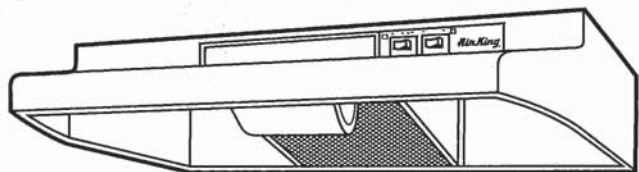

AV SERIES

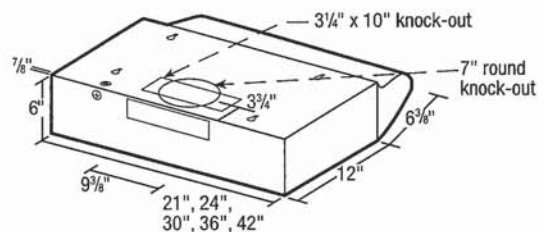

Filters

UL rated, class 2 filter.
 Grease Filter: RF35 - 8⁷/₈"x10³/₈" (included).
 Charcoal Filter: RF34 (not included).
 Combo Grease/Charcoal: RF55 (not included).

Available Finishes

White, Biscuit, Almond, Black & Stainless Steel.

EXPANDED PERFORMANCE										
Air Flow - CFM	Static Pressure (inches of w.g.)						Sones @ .1 SP	Fan Speed RPM	Power Watts	Apms
	0	0.05	0.1	0.15	0.2	0.25				
Vertical Ducting High	246	232	218	203	181	147	7.5	2973	87.0	2.1
Horizontal Ducting High	225	210	180	175	155	120	7.0	3024	87.0	2.1

PROJECT							ARCHITECT			
LOCATION							ENGINEER			
CONTRACTOR							SUBMITTED BY			DATE
FAN NUMBER	MODEL NUMBER	CFM	IN W.C.	RPM	WATTS	AMPS	SONES	QTY	OPTIONAL EQUIPMENT & REMARKS	



Air King: 820 Lincoln Avenue
 West Chester, Pennsylvania 19380-4466
 Tel: (610) 692-7400 • 877-304-3785
 Fax: (610) 696-8048

Canada:
 Brampton, Ontario
 Tel: 905-456-2033
 Fax: (905) 456-1015

Samsung

RF23J9011SG/AA

RF23J9011SG

Samsung RF23J9011SG - RF23J9011SG/AA French Door Refrigerator, 36 inch Width, ENERGY STAR Certified, Counter Depth, 22.5 cu. ft. Capacity, Thru Door Ice Dispenser, Exterior Water Dispenser, LED Lighting, Black Stainless Steel colour

Ratings & Reviews

3.8

Product Dimensions with Hinges, Handles and Door	35 3/4" W x 71 7/8" H x 28 7/8" D
Product Dimensions without Hinges and Door	35 3/4" W x 70 3/4" H x 24" D
Product Dimensions with Door without Handles	35 3/4" W x 71 7/8" H x 28 7/8" D
Product Dimensions with Doors Open	35 6/8" W x 71 7/8" H x 42 1/4" D
Shipping Dimensions	38 5/16" W x 78" H x 31 5/16" D
Net Height with Hinge	70"
Net Height without Hinge	70 3/4"
Width	35 3/4"
Weight	
Product Weight	352.7 lb.
Shipping Weight	385.8 lb.
Warranty	
1 Year	Parts/Labor
5 Years	Five (5) years Parts and Labor on sealed Refrigeration system only* (*Compressor, evaporator, condenser, drier, connecting tubing)
10 Years	Ten (10) years Part and Five (5) years Labor on Digital Inverter Compressor

69%

recommend this

[Read Reviews](#)

(1885 reviews)

Similar Colours and Options



RF23J9011SR
Cool Select Plus
Stainless Steel

Product Dimensions with Hinges, Handles and Door	35 3/4" W x 71 7/8" H x 28 7/8" D
Product Dimensions without Hinges and Door	35 3/4" W x 70 3/4" H x 24" D
Product Dimensions with Door without Handles	35 3/4" W x 71 7/8" H x 28 7/8" D
Product Dimensions with Doors Open	35 6/8" W x 71 7/8" H x 42 1/4" D
Shipping Dimensions	38 5/16" W x 78" H x 31 5/16" D
Net Height with Hinge	70"
Net Height without Hinge	70 3/4"
Width	35 3/4"
Weight	
Product Weight	352.7 lb.
Shipping Weight	385.8 lb.
Warranty	
1 Year	Parts/Labor
5 Years	Five (5) years Parts and Labor on sealed Refrigeration system only* (*Compressor, evaporator, condenser, drier, connecting tubing)

NA30N6555TS

SAMSUNG

30" Gas Cooktop

Installation Requirements

Countertop cut-out and minimum clearance dimensions:

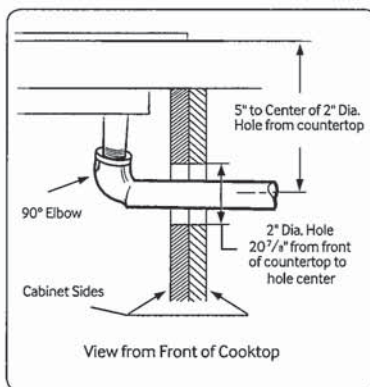
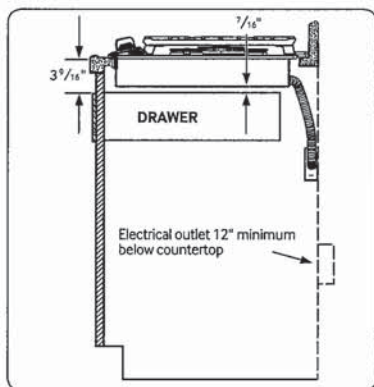
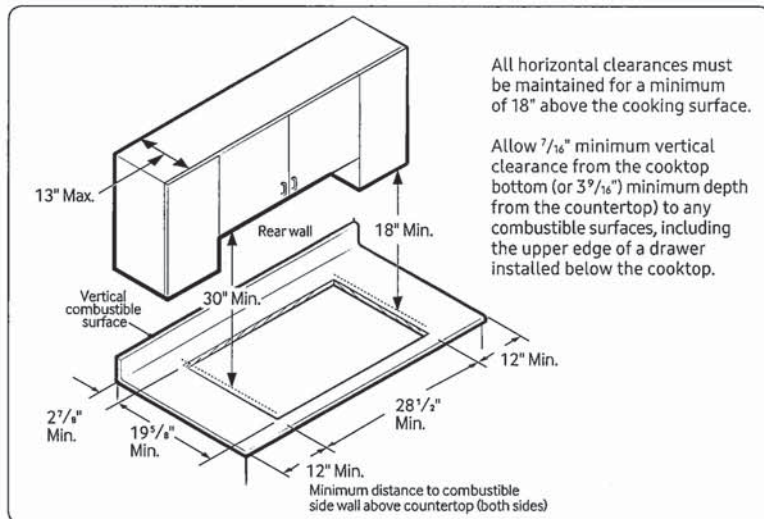

Total Power (BTU)

56K

Power Source

120V / 60 Hz / 1A

Gas Cooktop (BTU)

- Right Front: 13K
- Left Front: 9.5K
- Right Rear: 5K Simmer
- Left Rear: 9.5K
- Center: 19K (Dual)

Warranty

One (1) Year All Parts and Labor

Product Dimensions & Weight (WxHxD)

Outside (Max) Cooktop Dimensions:

30" x $5\frac{41}{72}$ " x $22\frac{1}{3}$ "

Cooktop Cut-Out Dimensions:

$28\frac{1}{2}$ " x $3\frac{1}{8}$ " x $19\frac{5}{8}$ "

Weight: 64.8 lbs. (66.4 lbs. Fingerprint Resistant Black Stainless Steel)

Shipping Dimensions & Weight (WxHxD)

Dimensions: $34\frac{11}{16}$ " x $10\frac{5}{8}$ " x $25\frac{5}{8}$ "

Weight: 73.0 lbs. (74.3 lbs. Fingerprint Resistant Black Stainless Steel)

Color

Stainless Steel

Model

NA30N6555TS

UPC Code

887276281681

Fingerprint Resistant

Black Stainless Steel

NA30N6555TG

887276281674

Installing Over a Single Oven

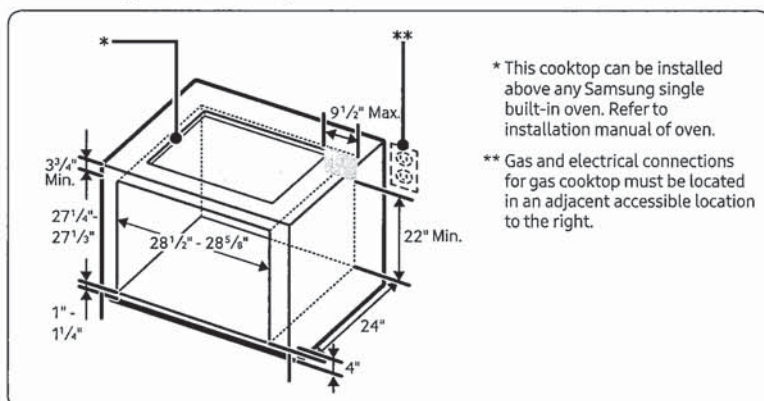

Cooktop Dimensions

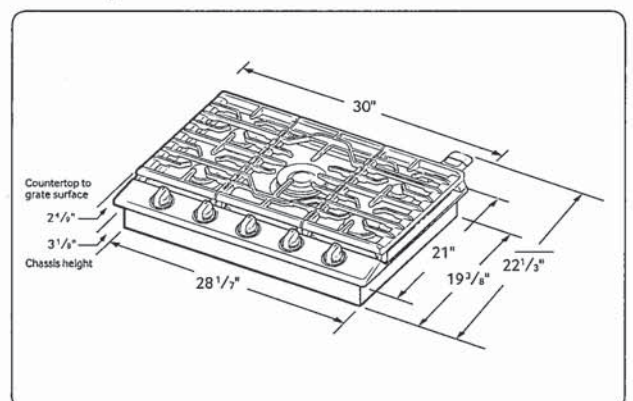

NA30N6555TS

SAMSUNG

30" Gas Cooktop

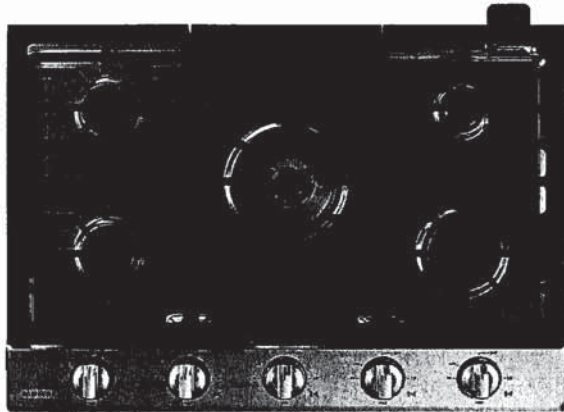

Signature Features

19K Power Burner

- Powerful burner boils water faster.

Griddle

- Cook breakfast foods, grill sandwiches, or sauté vegetables on the griddle.

LED Illuminated Backlit Knobs

- Visually lets you know your cooktop is on, even at a distance.

Available Colors



Stainless Steel (shown)



Fingerprint Resistant
Black Stainless Steel



19K Power Burner

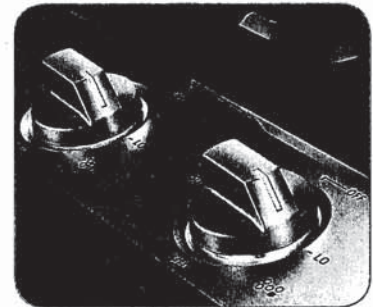

LED Illuminated Backlit Knobs

Features

- Wi-Fi Connectivity
- Powerful Cooktop
 - Right Front: 13K BTU
 - Left Front: 9.5K BTU
 - Right Rear: 5K BTU
 - Left Rear: 9.5K BTU
 - Center: Dual, 19K BTU

- Cast Iron 3-Piece Grates
- Sealed Burners
- Burner On/Off Monitoring
- ADA Compliant

Convenience

- LP Conversion Kit



ADA Compliant

NQ70M7770DS

SAMSUNG

30" Microwave Combination Wall Oven

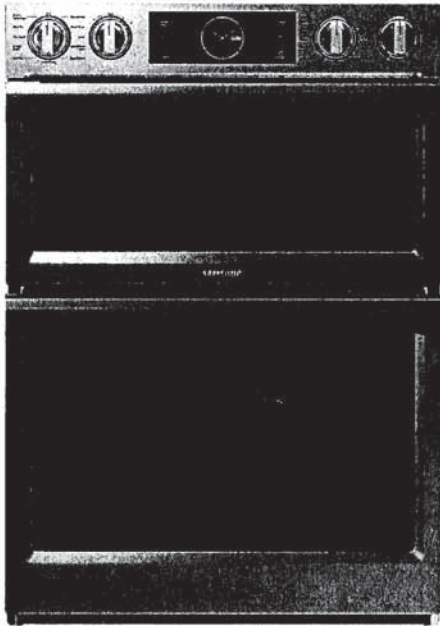

Signature Features

Steam Cook (Oven)

- Delivers moisture at precise times for a crisp, browned outside and tender inside.

Speed Cook (Microwave)

- Cook food faster and more evenly by using power convection.

Flex Duo™ (Oven)

- Cook two dishes at different temperatures simultaneously with the Smart Divider.

Available Colors



Stainless Steel (shown)



Black Stainless Steel

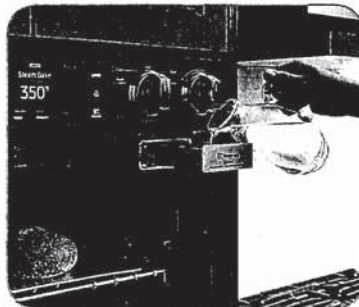

Steam Cook

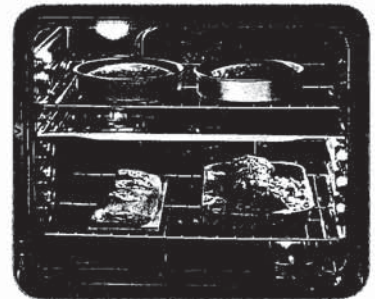

Flex Duo™

Features

- Digital-Analog Controls
- 1.9/5.1 cu. ft. Capacity
- Hybrid Clean and Self-Clean (Oven)
- Gourmet Cook (Oven)
- Dual Convection (Oven)
- Wi-Fi Connectivity
- Wi-Fi Enabled Temperature Probe (Oven)
- LED Spotlights (Oven)
- Easy View Window
- 3 Heavy-Duty Racks including a Gliding Rack (Oven)
- Soft-Close Door (Oven)

- Ceramic Plate (Microwave)
- Rapid Preheat (Oven)
- Auto Latch Microwave Door
- 6 Oven Modes including Steam Bake and Steam Roast
- Blue LED Illuminated Knobs
- Broil Element
- Smart Control Key (Oven)
- 6 Rack Positions (Oven)
- Drop-Down Door Design
- LCD Display

Convenience

- Hidden Heating Element (Oven)
- Sabbath Mode (Oven)
- Delay Start (Oven)
- Proofing (Oven)
- Warming Mode (Oven)
- Kitchen Timer
- Child Safety Lock
- Convection Conversion

NQ70M7770DS

SAMSUNG

30" Microwave Combination Wall Oven

Cabinet Dimensions

Combination Oven Installed in Cabinet

* Junction Box

** Allow a minimum of 22" for clearance to adjacent corners, drawers, walls, etc. when door is open.

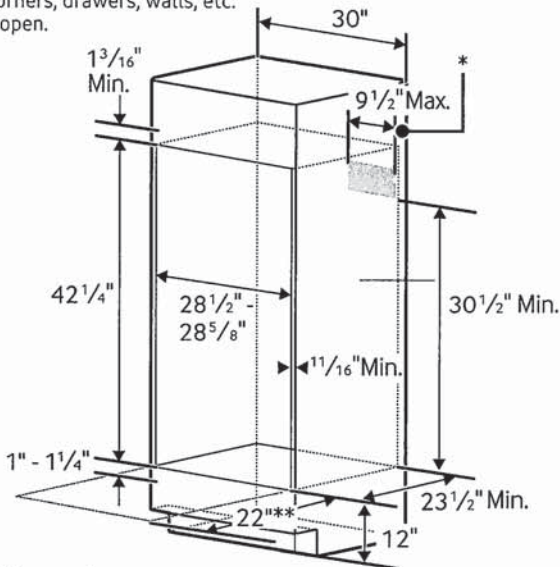

Product Dimensions

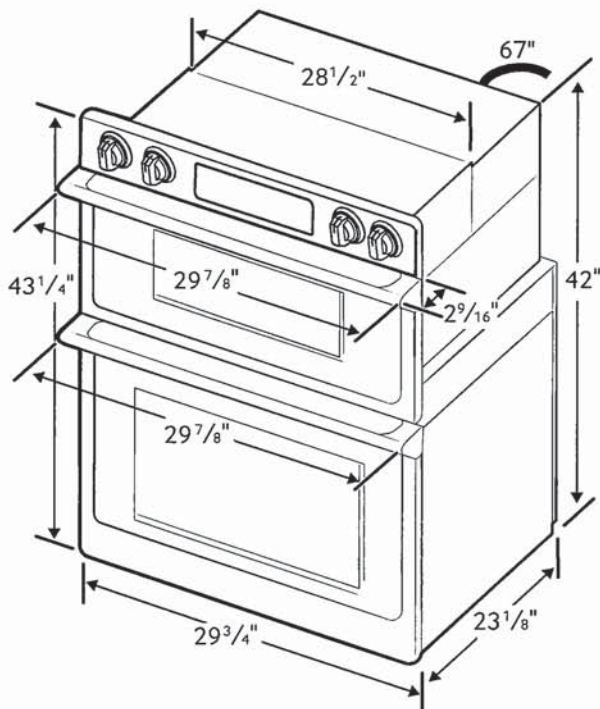

Total Capacity: 1.9/5.1 cu. ft.

- Microwave: 1.9 cu. ft.
- Wall Oven: 5.1 cu. ft. total, 2.8/2.2 cu. ft.
- Hidden Bake Element
- Bake: 175°F–550°F
- Convection Bake: 175°F–550°F
- Convection Roast: 175°F–550°F
- Broil: Low-High
- Steam Bake: 230°F–550°F
- Steam Roast: 230°F–550°F
- Proofing
- Sabbath Mode

Warranty

One (1) Year All Parts and Labor
 Ten (10) Years Parts Warranty for Magnetron

Product Dimensions & Weight (WxHxD)

Outside (Max) Combination Oven Dimensions:
 29⁷/₈" x 43¹/₄" x 25¹¹/₁₆"

Combination Oven Cut-Out Dimensions:
 28¹/₂" x 42¹/₄" x 23¹/₂"

Weight: 262.4 lbs.

Shipping Dimensions & Weight (WxHxD)

Dimensions:
 33⁵/₈" x 48³/₁₆" x 29⁵¹/₆₄"

Weight: 291.1 lbs.

Color

Stainless Steel
 Black Stainless Steel

Model

NQ70M7770DS
 NQ70M7770DG

UPC Code

887276195186
 887276195162

RATING	
240V	9.5 kW
208V	7.2 kW
BREAKER SIZE	
240V	40 Amps
208V	40 Amps

Actual color may vary. Design, specifications, and color availability are subject to change without notice. Non-metric weights and measurements are approximate.

©2018 Samsung Electronics America, Inc. 85 Challenger Road, Ridgefield Park, NJ 07660. Tel: 800-SAMSUNG. samsung.com. Samsung is a registered trademark of Samsung Electronics Co. Ltd.